

EXPANSION JOINT

NOTE: Extra Thickness to be Subsidiary to Price of Square Yards Pavement

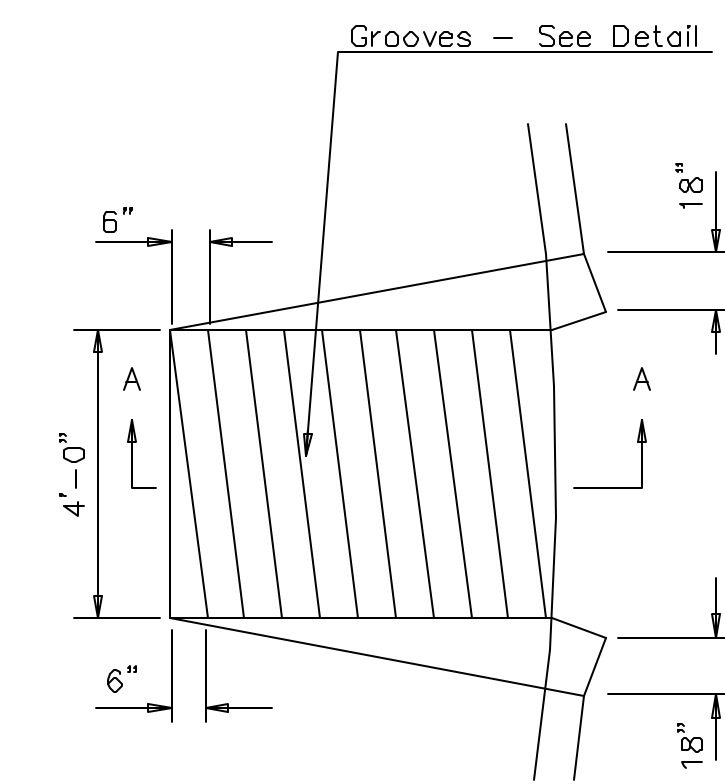

WHEELCHAIR RAMP PLAN VIEW

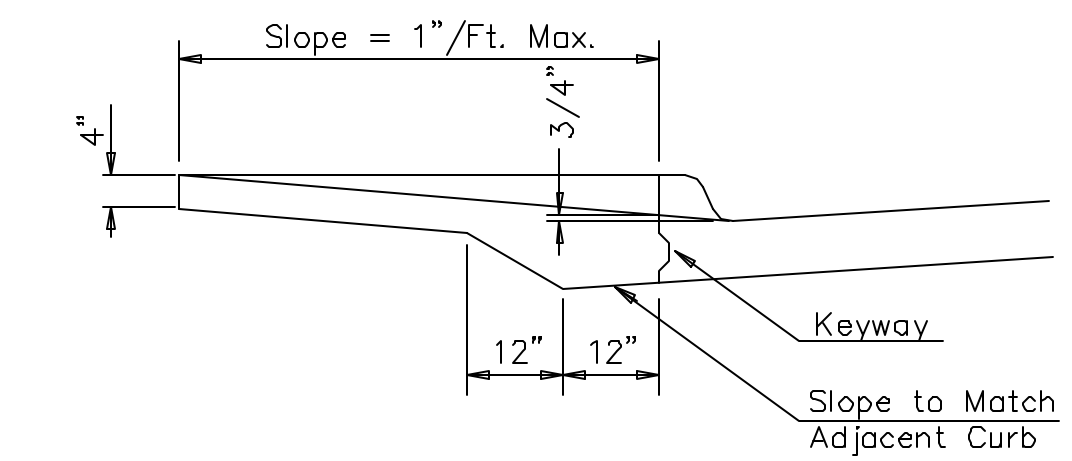

SECTION A-A

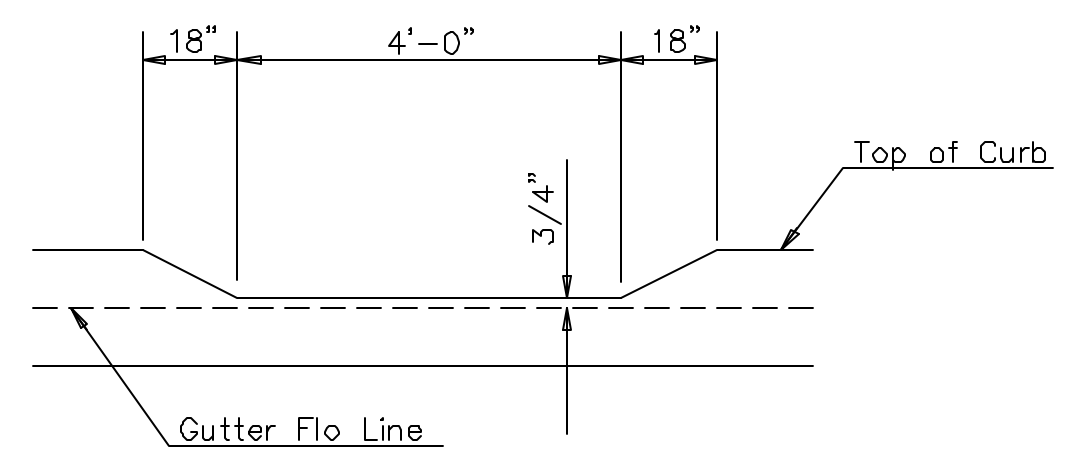

DEPRESSED CURB DETAIL

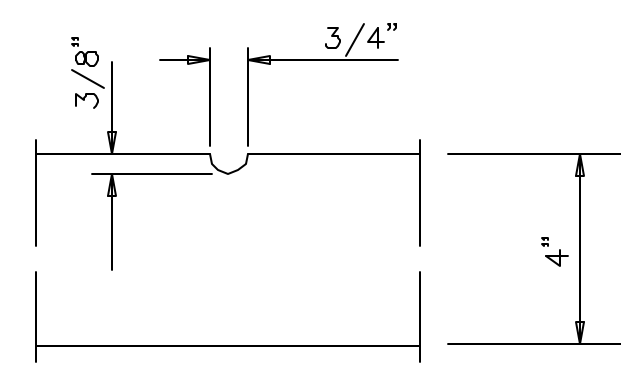

GROOVE DETAIL

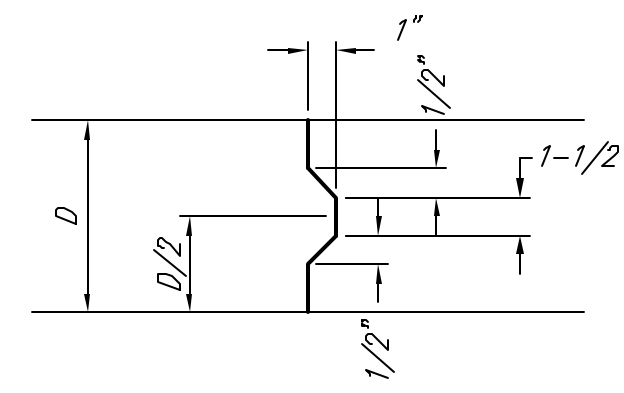

KEYWAY DETAIL

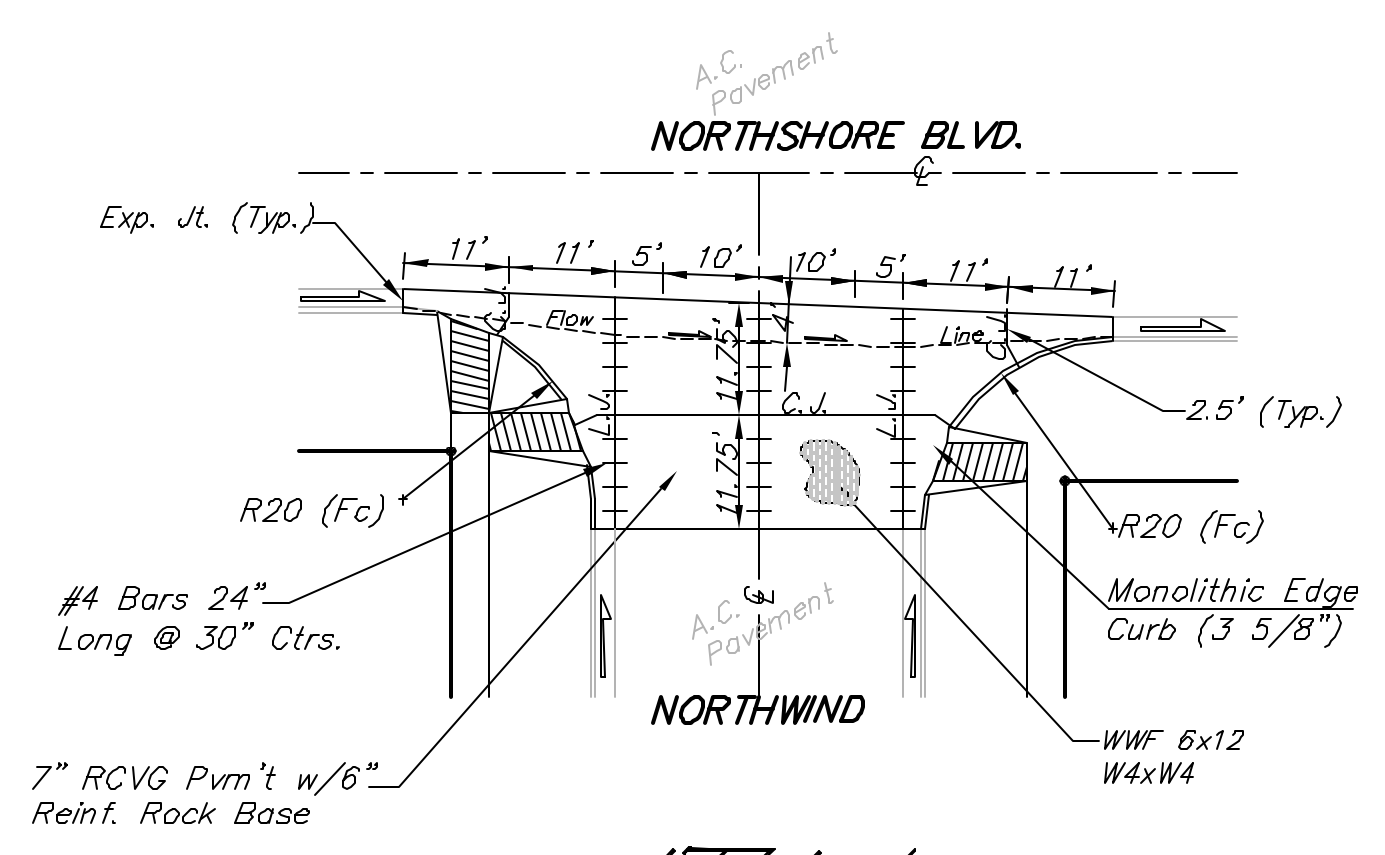

Scale: 1" = 20'

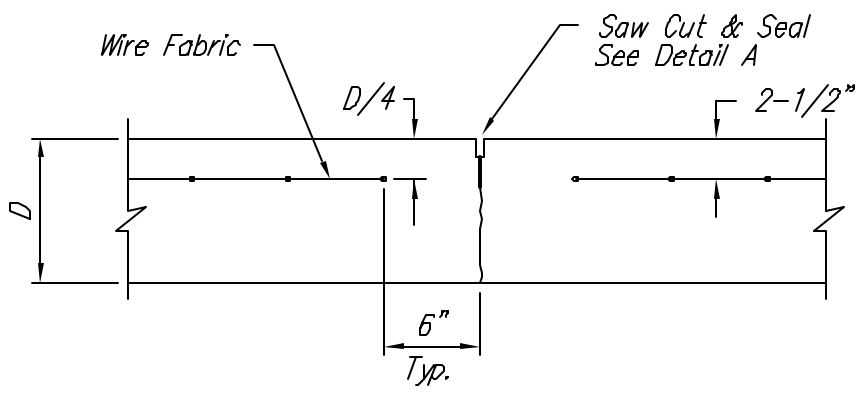

CONTRACTION JOINT DETAIL (C.J.)

WHEELCHAIR RAMP DETAIL

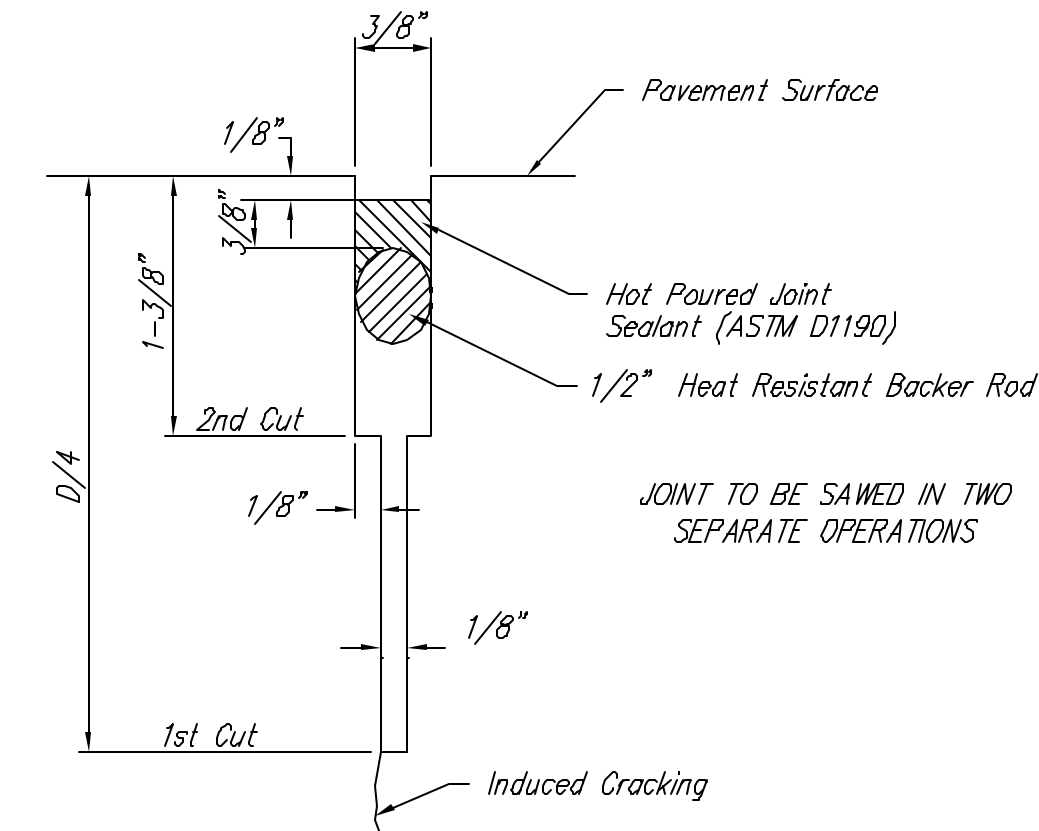

SAW JOINT DETAIL "A"

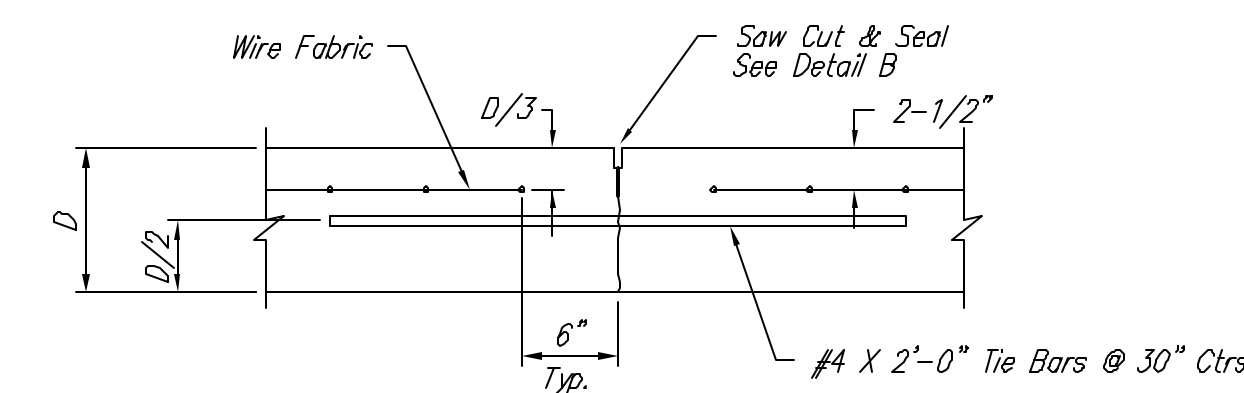

LONGITUDINAL JOINT DETAIL (L.J.)

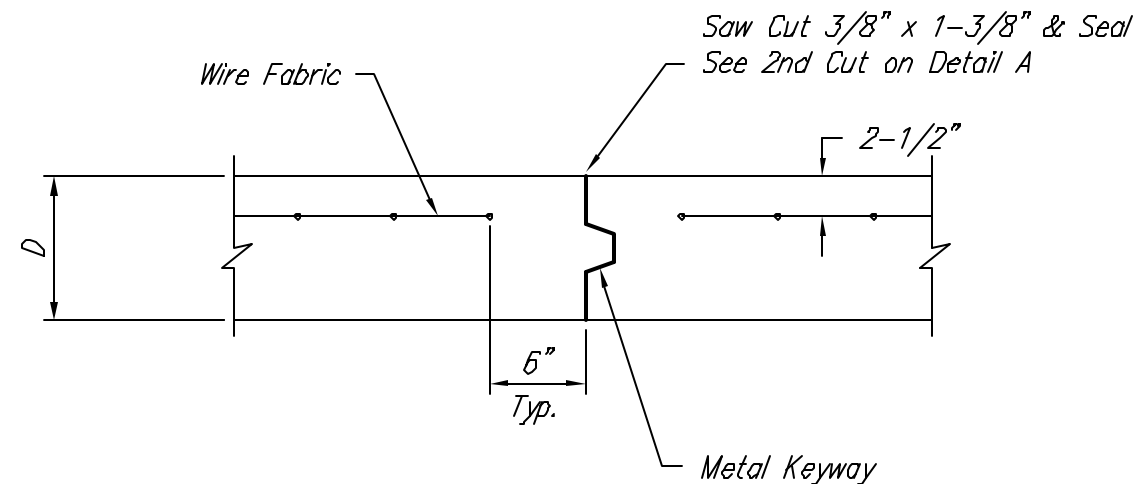

OPTIONAL CONTRACTION JOINT (CONSTRUCTION JOINT)

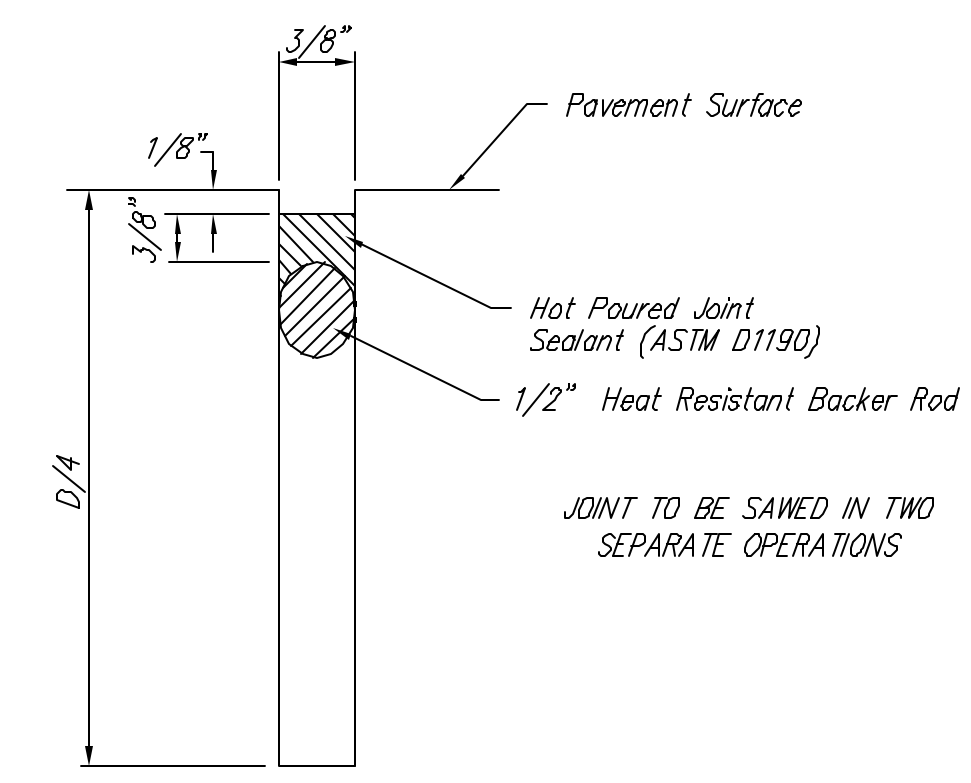

SAW JOINT DETAIL "B"

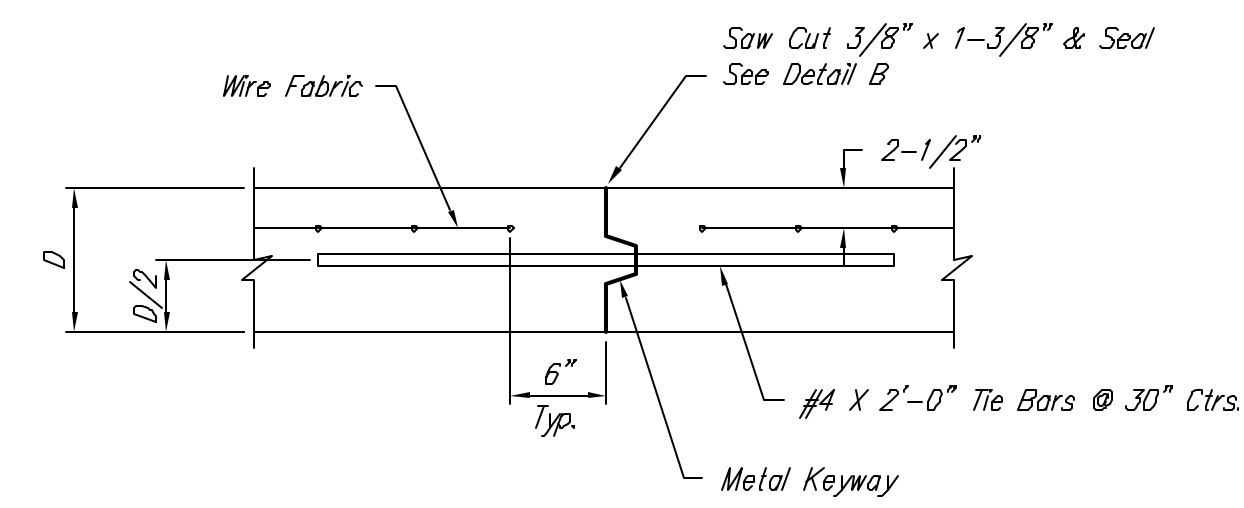

OPTIONAL LONGITUDINAL JOINT DETAIL (L.J.) (CONSTRUCTION JOINT)

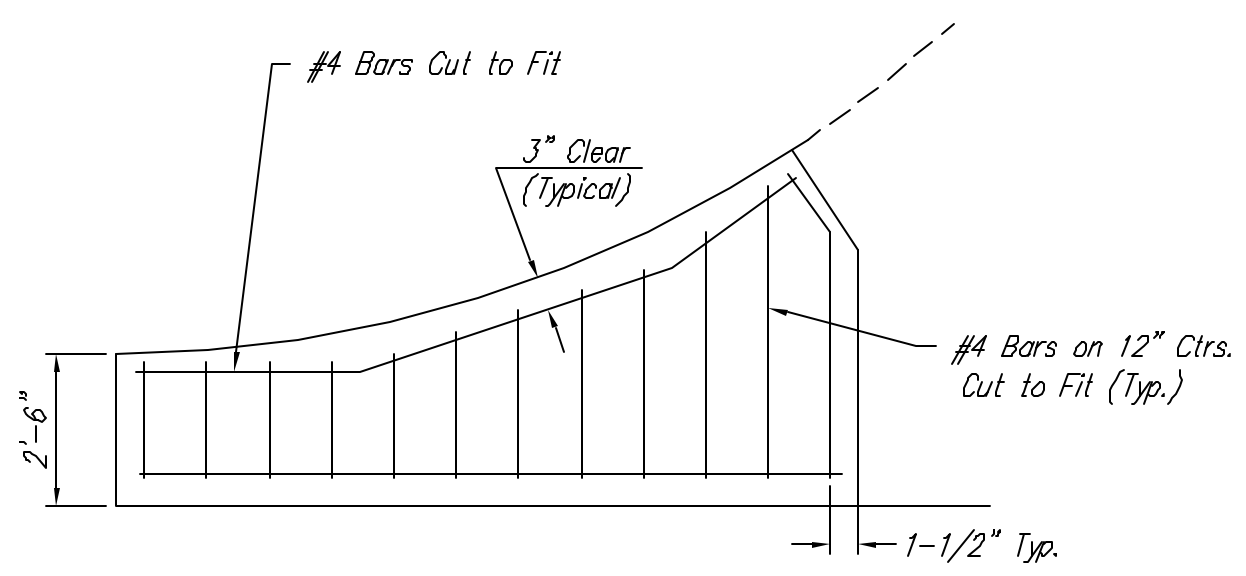

WING REINFORCING DETAIL

NOTE: 6" X 12" W4XW4 Wire Fabric Reinforcing Shall Be Placed So That The Wires With The 6" Spacing Will Run Parallel With The Longitudinal Joints.

MISCELLANEOUS DETAILS

BAUGHMAN COMPANY P.A.
ENGINEERING, SURVEYING, & PLANNING
316-262-7271 • 315 ELLIS • WICHITA, KANSAS 67211

DESIGN STAFF	DRAWN STAFF	APPROVED	DATE 5/28/03	SCALE NONE	SHEET 6 OF 34
--------------	-------------	----------	--------------	------------	---------------