

EXPANSION JOINT

NOTE: Extra Thickness to be Subsidiary to Price of Square Yards Pavement

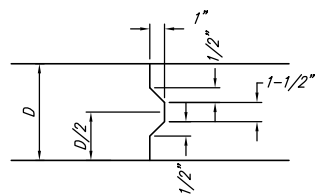

KEYWAY DETAIL

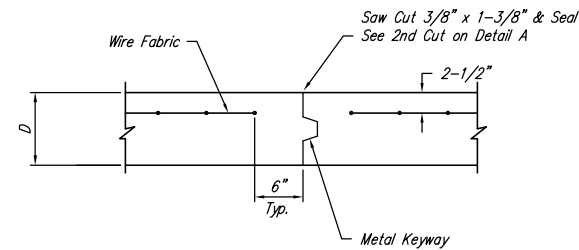

OPTIONAL CONTRACTION JOINT

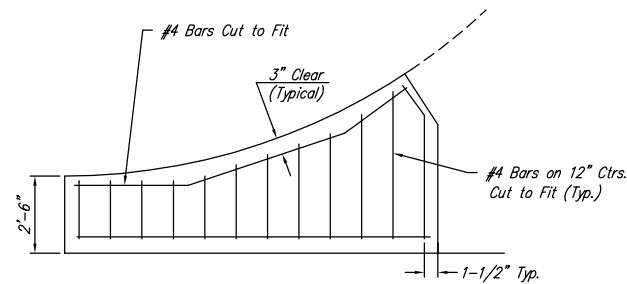

WING REINFORCING DETAIL

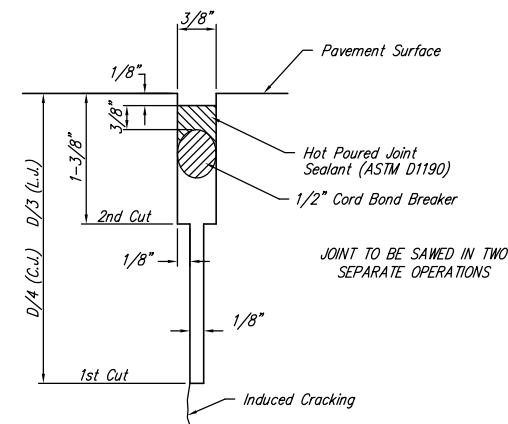

SAW JOINT DETAIL

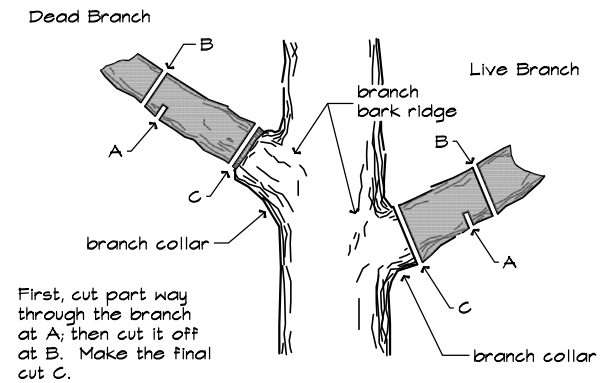

First, cut part way through the branch at A, then cut it off at B. Make the final cut C.

TREE TRIMMING DETAIL
NOT TO SCALE

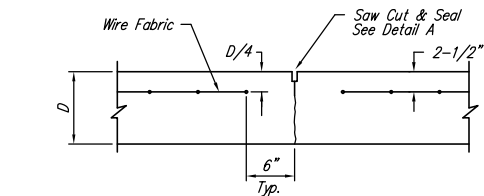

CONTRACTION JOINT DETAIL (C.J.)

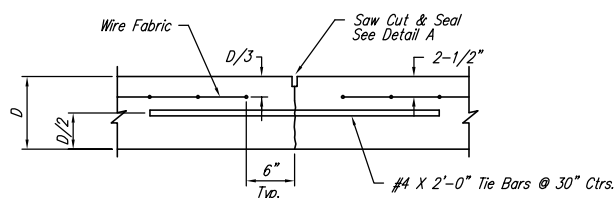

LONGITUDINAL JOINT DETAIL (L.J.)

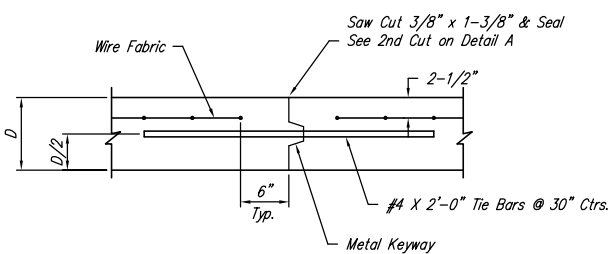

OPTIONAL LONGITUDINAL JOINT DETAIL (L.J.)

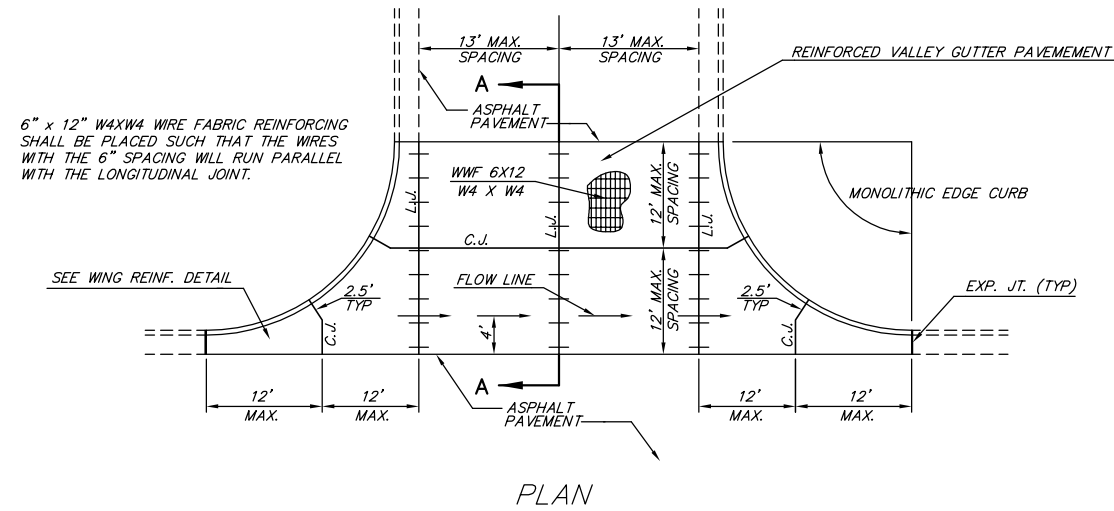

PLAN

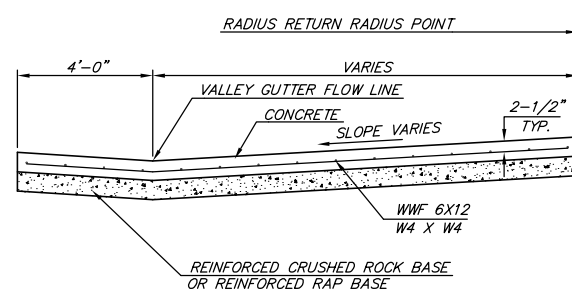

SECTION A-A

REINFORCED VALLEY GUTTER DETAIL

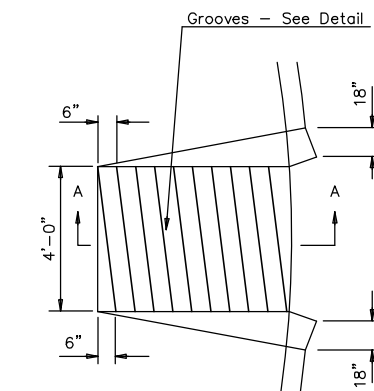

WHEELCHAIR RAMP PLAN VIEW

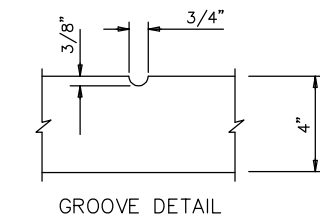

GROOVE DETAIL

WHEELCHAIR RAMP DETAIL

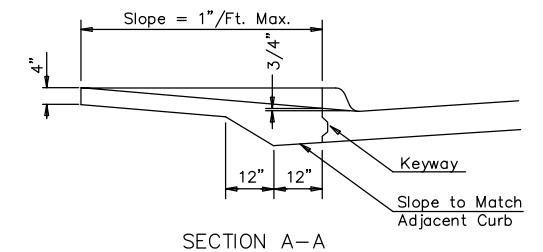

SECTION A-A

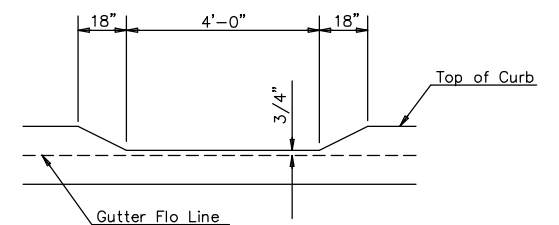

DEPRESSED CURB DETAIL

THE CITY OF WICHITA

 CITY ENGINEER'S OFFICE
 455 NORTH MAIN STREET
 WICHITA, KANSAS 67202
 (316) 268-4201
 (316) 268-4114 FAX

VALLEY GUTTER DETAILS

WHEELCHAIR RAMP DETAILS

NEIL D. CABLE - CITY ENGINEER

PROJECT NUMBER 472-83647 INDEX CODE 765777

DATE MAR 03 SHEET 4 OF 19