

STATE	PROJECT NO.	YEAR	SHEET NO.	TOTAL SHEETS
KANSAS	87 TE-0623-01	2014	24	35

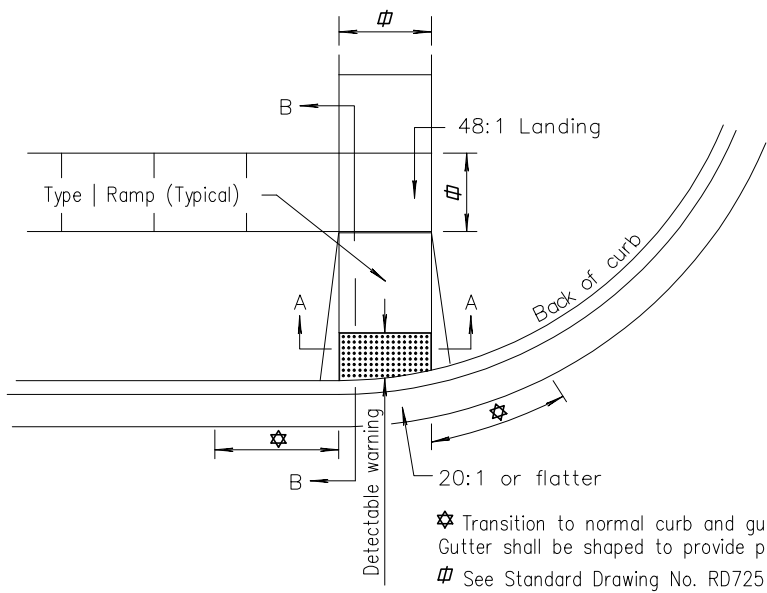

TYPICAL PLAN

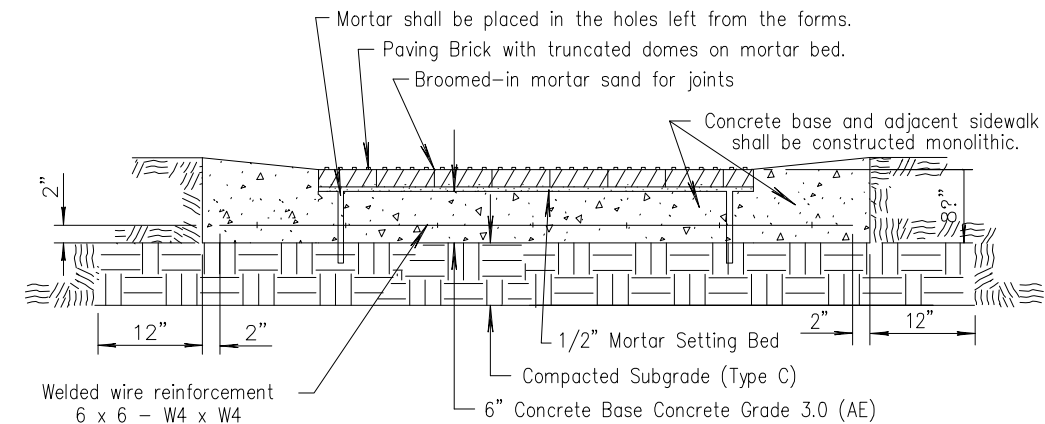

TYPICAL SECTION OF PAVER BRICK SECTION A-A

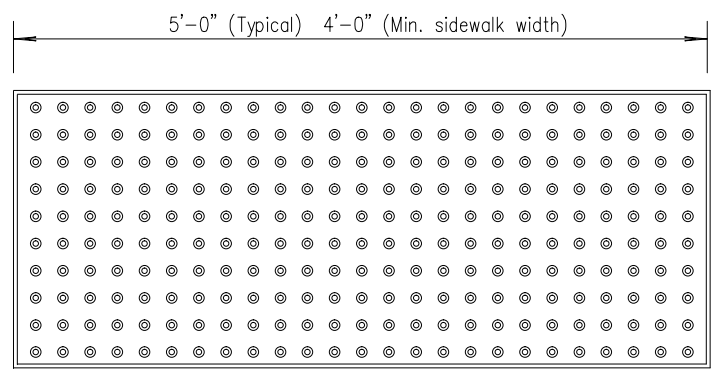

COMPOSITE PANEL with TRUNCATED DOMES

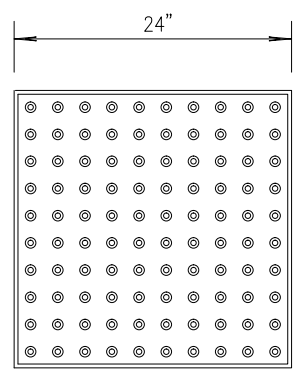

PRESTRESSED RAMP PANEL with TRUNCATED DOME SURFACE

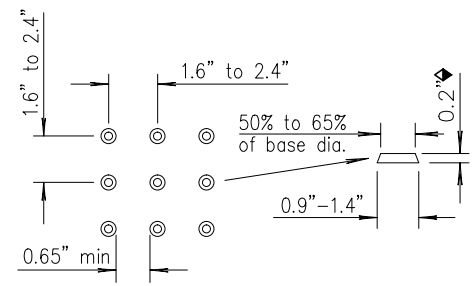

TRUNCATED DOME DIMENSIONS for SQUARE PATTERN (Parallel Alignment)

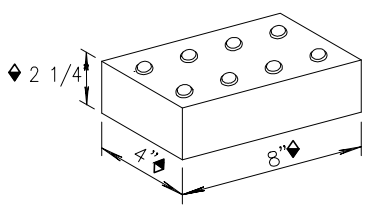

PAVER BRICK WITH TRUNCATED DOME SURFACE

These dimensions are nominal.

GENERAL NOTES

Details shown on Standard Drawing RD725 & RD725A may not be appropriate for all locations. Design new project construction to criteria shown on these drawings unless impracticable by site restrictions. For existing sidewalk replacement, follow these drawings to the maximum extent feasible.

Use Paving Brick, Prestressed or Composite Panel (Truncated Dome Surface) units that meet the requirements of the Standard Specifications and comply with the American Disabilities Act. Use a contrasting color paving brick or panel to adjacent surfaces.

Cover the ramp width and 24" length with truncated dome surface, see examples Standard Drawing RD725 & RD725A. Saw cut (only) bricks or panels with not less than 25% of a full brick or panel installed. Place Truncated Dome Bricks or Panels to align parallel in the direction of pedestrian travel.

Prestressed or Composite Panels are installed in fresh concrete, Paving Brick require mortar bed and mortar sand, see Standard Specifications for requirements.

The entire ramp or median crossing will be bid as "Sidewalk Ramp" and payment is measured by the square yard. Materials and labor to install sidewalk ramp are subsidiary to the bid item "Sidewalk Ramp."

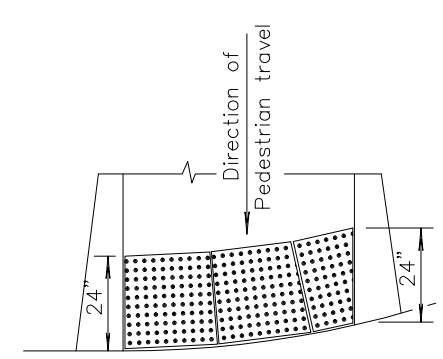

RADIUS CURB DETAILS
Cut Prestressed Ramp Panels to fit.

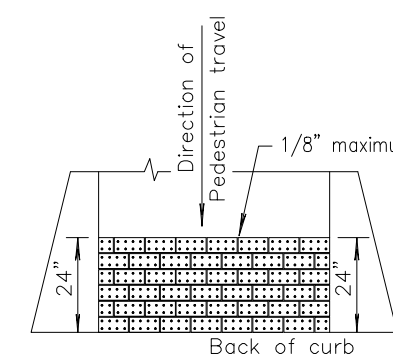

STRAIGHT CURB DETAILS

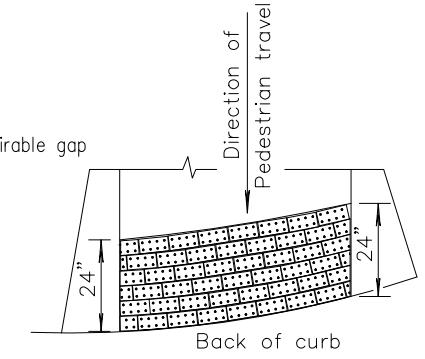

RADIUS CURB DETAILS

Installation shown for paving brick is running bond, use of other patterns is allowed with Engineer approval. Rotation 90° of Running Bond pattern is allowed to reduce space between bricks on radius installation, keep this space to a minimum. Place truncated domes on bricks in parallel alignment to pedestrian travel as shown.

Radius curb or greater than 5' width ramp will require more than one panel as approved by the Engineer. Limit number of panels installed at each site. Layouts shown are for example and may vary in the field.

Acceptable with no mixing of types within an installation.

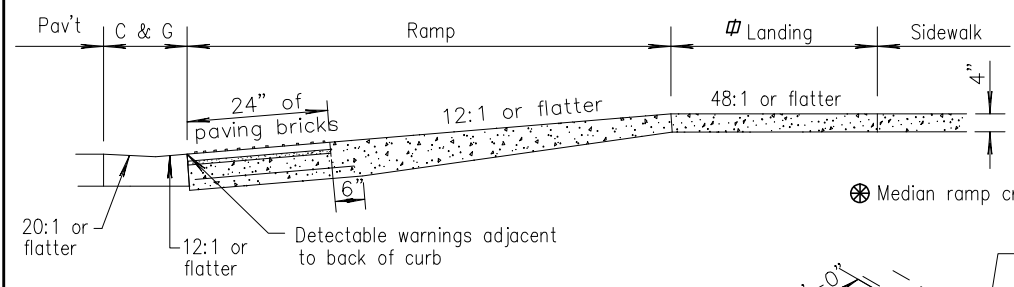

SECTION B-B

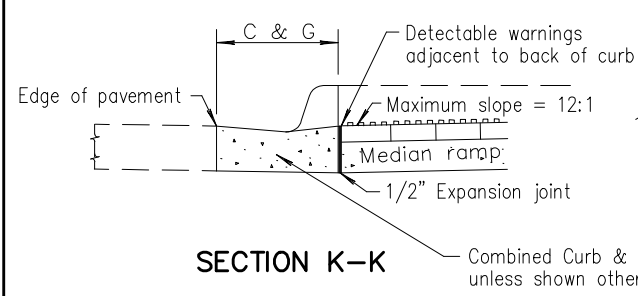

SECTION K-K

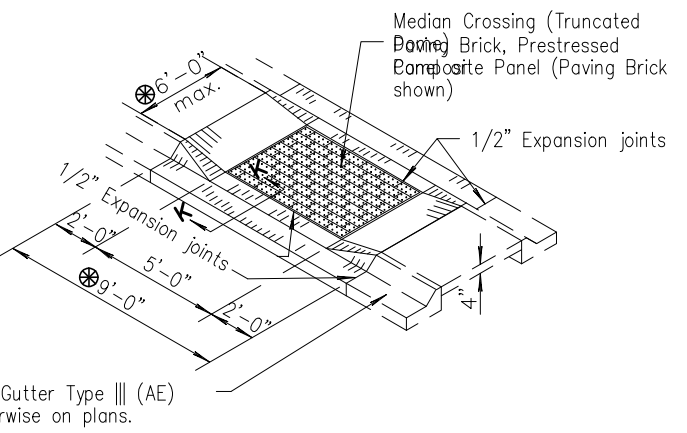

NARROW MEDIAN RAMP CROSSING

Note: A Median Ramp Crossing shall be constructed at Crosswalk locations.

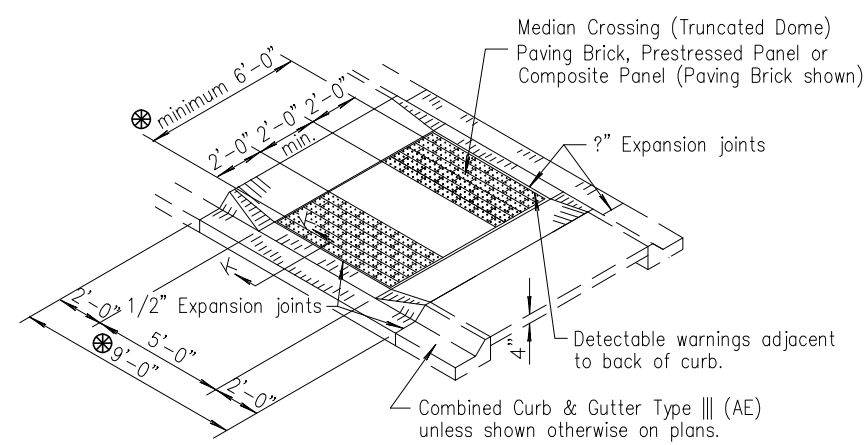

WIDE MEDIAN RAMP CROSSING

Note: A Median Ramp Crossing shall be constructed at Crosswalk locations. Wider median islands will result in a 2' minimum gap between the truncated dome areas.

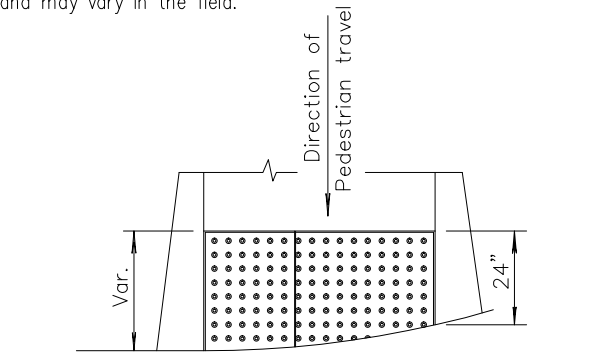

RADIUS CURB DETAILS (COMPOSITE)
Cut Radius from 3'-0" Long Composite Panel.

NO.	DATE	REVISIONS	BY	APP'D
4	2-10-10	Added Composite Panel	S.W.K.	J.O.B.
3	8-15-05	Added Prestressed Ramp Panel alt.	S.W.K.	J.O.B.
2	2-24-05	Class to Grade conc., wire reinf.	S.W.K.	J.O.B.
1	8-20-03	Revised details and notes	S.W.K.	J.O.B.

KANSAS DEPARTMENT OF TRANSPORTATION

AUXILIARY DETAILS FOR SIDEWALK & STEPS

RD725A

DESIGNED	4-7-10	APP'D	JAMES O. BREWER
DESIGN CK.	TRACED	QUANTITIES	TRACED
DETAIL CK.	DETAIL CK.	QUAN. CK.	TRACE CK. King