

FHWA REG. NO.	STATE	PROJECT NO.	YEAR	SHEET NO.	TOTAL SHEETS
7	KANSAS	87N-0116-01	1999	70	110

Note:
 ReflectORIZED Paint Material shall meet the requirements of Fed. Specs. TT-P-85e and TT-B-1325, Type 1, Grade A. Application shall be in accordance with manufacturers instructions.

DATE	
BY	
REFERENCES NOTED	
REFERENCES CHECKED	

SCALE: 1 : 500

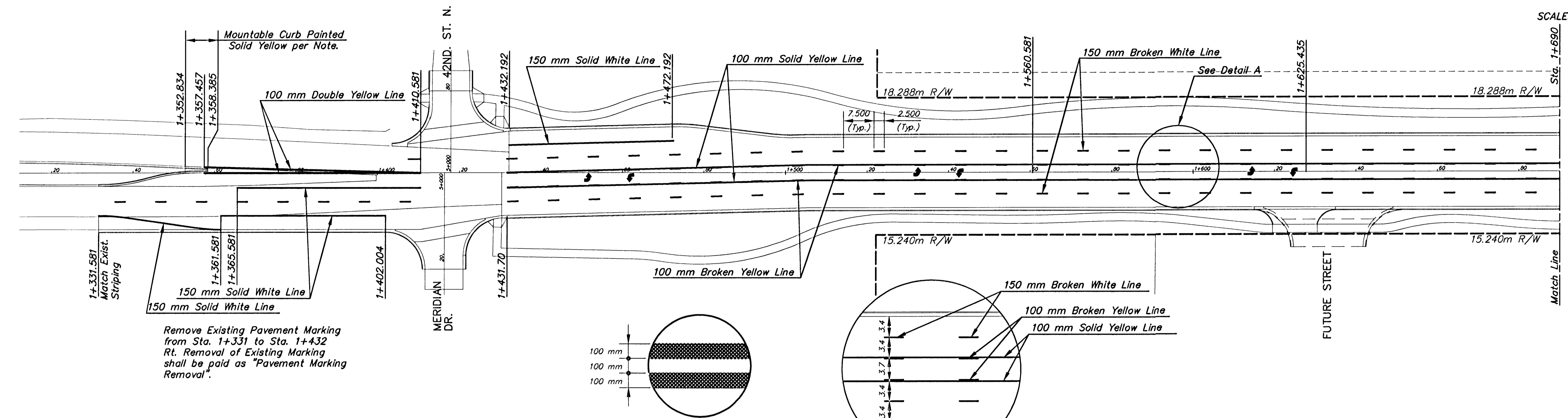

Remove Existing Pavement Marking from Sta. 1+331 to Sta. 1+432 Rt. Removal of Existing Marking shall be paid as "Pavement Marking Removal".

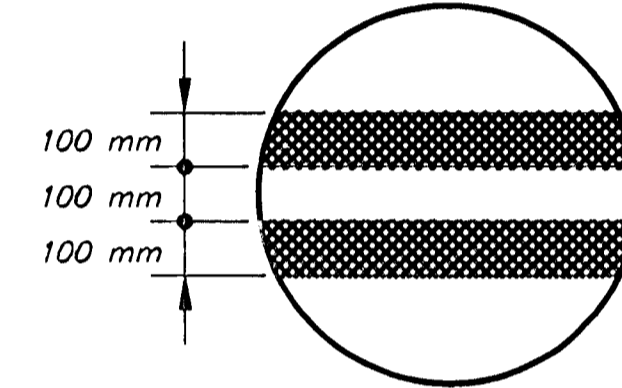

100 mm DOUBLE YELLOW DETAIL

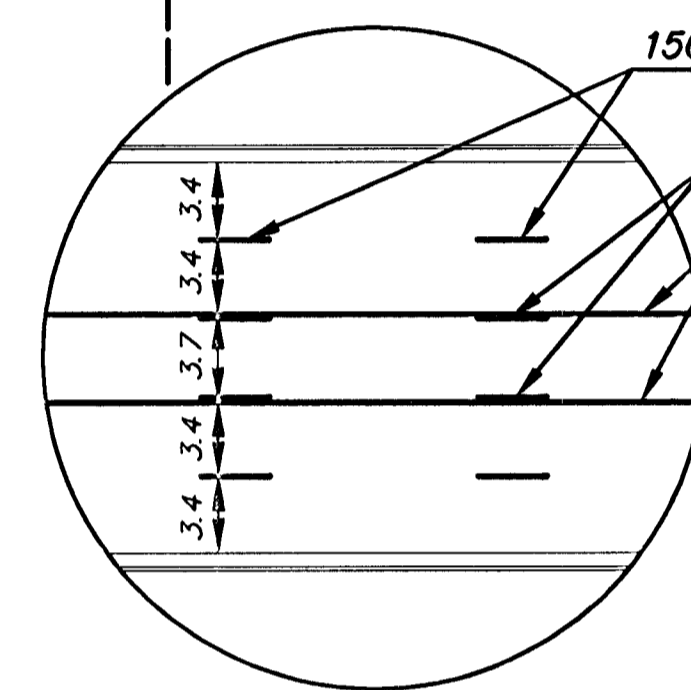

DETAIL A

SCALE: 1 : 500

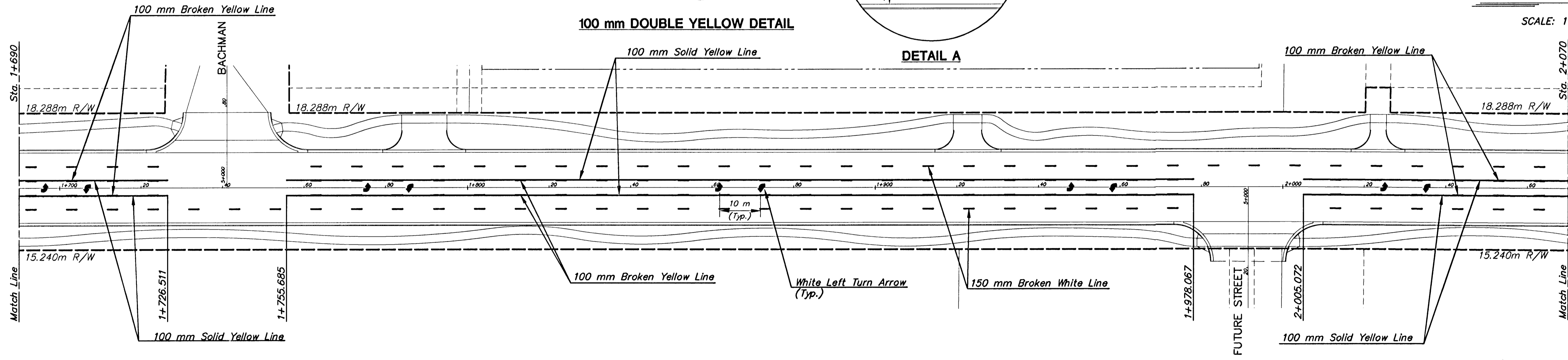

2	8-99	ADDED FUTURE STREET ENTRANCE STA. 1+992	WNJ	DCH
1	7-99	PAVEMENT WIDENING	WNJ	DCH
NO.	DATE	REVISIONS	BY	APP'D

KANSAS DEPARTMENT OF TRANSPORTATION
**MERIDIAN AVE.
 PAVEMENT MARKING**
 PROJ. NO. 87N-0116-01 SEDGWICK COUNTY
MID-KANSAS ENGINEERING CONSULTANTS, INC.
 WICHITA, KANSAS

DESIGNED BY: WNJ CHECKED BY: DCH
 DRAWN BY: WNJ DATE: DEC. 1998 SHEET 70 OF 110

K:\CIVIL\97043\REVISED\STRIP\97043511.DWG Ff1 Aug 06 13:41:45 1999

G:\CIVIL\97043\STRIP\97043511.DWG