

- * Non-arterial streets
BC-1, SC-1 AND PG 64-22
 - △ Arterial streets
BM-2 PG 64-22(Base) PG 70-28(Surface)
- Base Course thicker than 4" shall be installed in two lifts

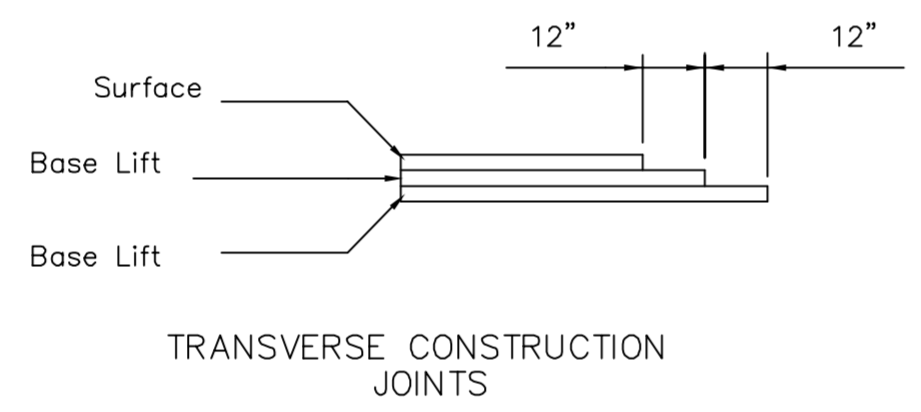

Transverse construction joints shall be constructed in flexible base pavement at locations where pavement joins existing flexible base pavement as show by the detail. All costs associated with the construction of the transverse joint shall be included in the bid price for Square Yards of pavement.

GENERAL NOTES

Fabric base reinforcement shall be an approved grid. Fabric base reinforcement shall be installed in accordance with manufacturer's recommendations. Crushed rock shall be uniformly graded from 1 - 1/2" maximum size to not more than 10% passing a No. 200 sieve. Rock quality shall be the same as specified for coarse aggregate for concrete mixes.

Rock base is to be compacted and smoothed with a steel faced roller prior to placement of asphalt. Tack coat will not be applied to rock base.

A tack coat of emulsified asphalt (SC-1H or CSS-1H) shall be applied to an approximate rate of 0.05 gallons per square yard between each lifts of asphaltic material.

Bituminous base and asphaltic concrete wearing surface shall be placed with a laydown machine having automatic controls for line and grade.

Construction joints in each lift shall be staggered a minimum distance of one (1) foot from joints in preceding lifts and placed so that a joint will be constructed on the centerline of the top lift.

The asphaltic concrete pavement between the combined curb and gutter shall be paid as square yards of of pavement.

STREET NAME	"WL"	"M"	"WR"	STATION	CENTER LINE	ROW DIMENSION	MEDIAN DESCRIPTION	SLOPE	ROCK THICKNESS	PAVEMENT THICKNESS	COMMENTS
ELDER	13.00'	0.00'	13.00'	10+55.55-22+53.85	30.00'	*	N/A	3.125%	5"	5"	* - 30' Half Street R/W
ELM	13.00'	0.00'	13.00'	50+00.00-53+00.40	30.00'	*	N/A	3.125%	5"	5"	* - 30' Half Street R/W
ELM	12.00'	0.00'	12.00'	53+80.32-55+09.25	30.00'	*	N/A	3.125%	5"	5"	* - 30' Half Street R/W

REVISED: OCTOBER 2015



**ASPHALT PAVING
DETAIL**

CITY ENGINEER
GARY JANZEN, P.E.

PROJECT NUMBER 472-85221	OCA NUMBER 766336	DATE
CITY ENGINEER'S OFFICE CITY HALL - SEVENTH FLOOR 455 NORTH MAIN STREET WICHITA, KANSAS 67202-1620 (316) 268-4501		SHEET 4 of 30