

PLOTTED: Tuesday, April 15, 2016 @ 12:29PM
 C:\Chin\Bachong\DETAILS\10264-Deck Patching.dwg

GENERAL NOTES

DECK PATCHING: (Area Prepared for Patching, KDOT Specification 731)

Prior to placing overlay, the Contractor shall prepare the deck by removing unsound concrete from the bridge deck, cleaning reinforcing bars, fill the removed patched areas with concrete, and preparing the entire area of deck for concrete polymer overlay. Quantity shown on Sheet No. 14 is an estimate of the areas involved. The exact areas shall be determined by tapping, before, during and after chipping operation to assure that all unsound concrete has been removed. In areas for Full-Depth Patching, as shown on this sheet, forms shall be provided to enable placement of concrete after full-depth removal of the bridge slab. Forms may be suspended from existing reinforcing bars by wire ties, or other methods approved by the Engineer may be used. See KDOT Specifications. The exact areas shall be determined by the Engineer.

REINFORCING IN BRIDGE DECK:

Care should be exercised to prevent cutting, stretching or damaging exposed reinforcing steel. Extreme care should be exercised to avoid breaking the bond between the reinforcing steel and concrete where bars are partially exposed yet remain anchored in sound concrete. Reinforcing steel damaged, cut or deteriorated shall be replaced as directed by the Engineer. See table on this sheet for minimum splice length required. Replacement of damaged bars shall be paid for as "Reinforcing Steel, Gr. 60 (Repair)".

REPAIR OF EPOXY COATED REINFORCING STEEL:

Replace any epoxy coating that is removed from the reinforcing steel during the concrete removal process. Thoroughly clean damaged areas with a stiff wire brush to remove dirt and damaged coating. Apply an approved patching material in accordance with manufacturer's recommendations. Avoid dripping any patching material onto existing concrete that will have new concrete placed against it. See KDOT Specifications.

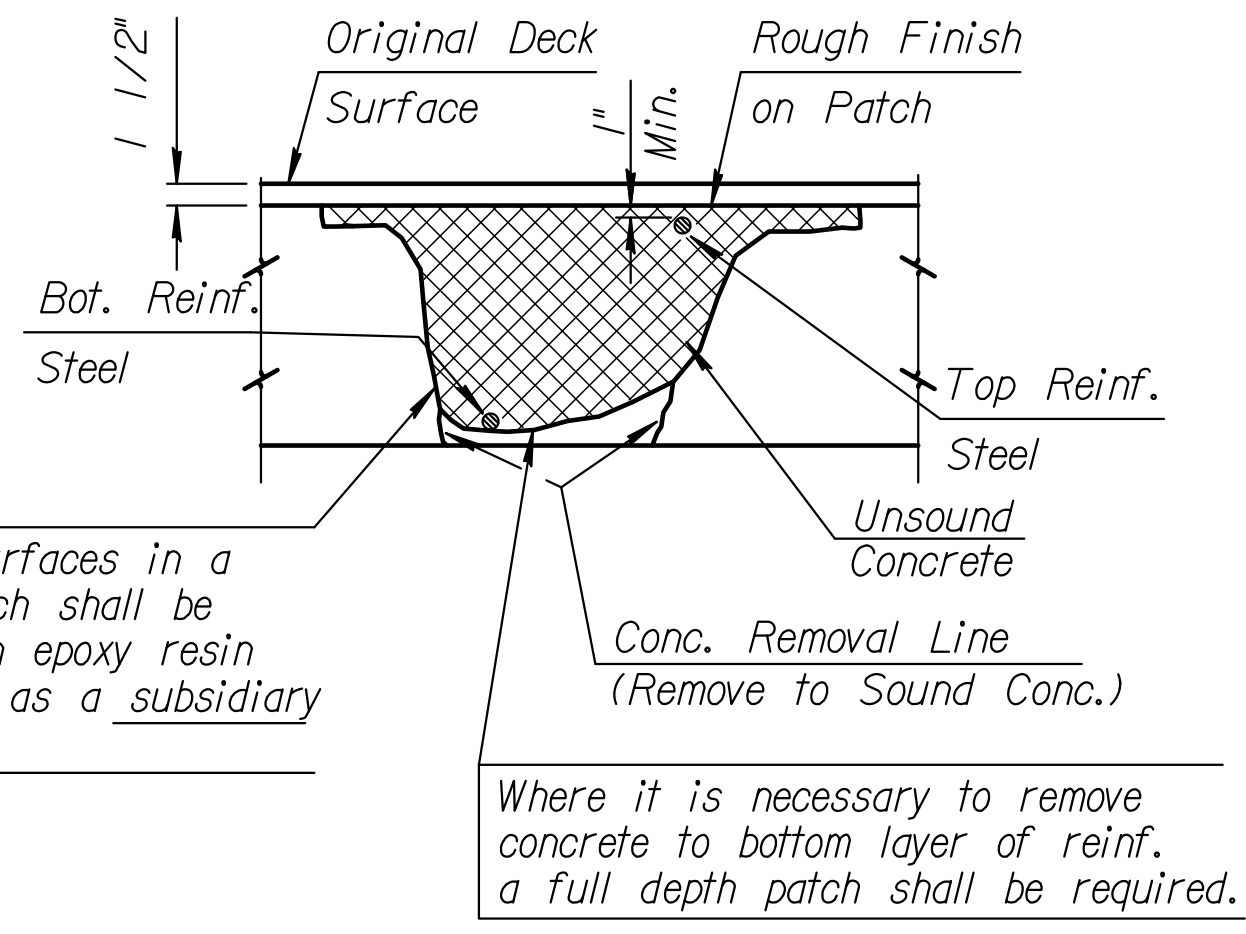

FULL DEPTH PATCHING
(Paid for as "Area Prepared for Patching (Full Depth)")

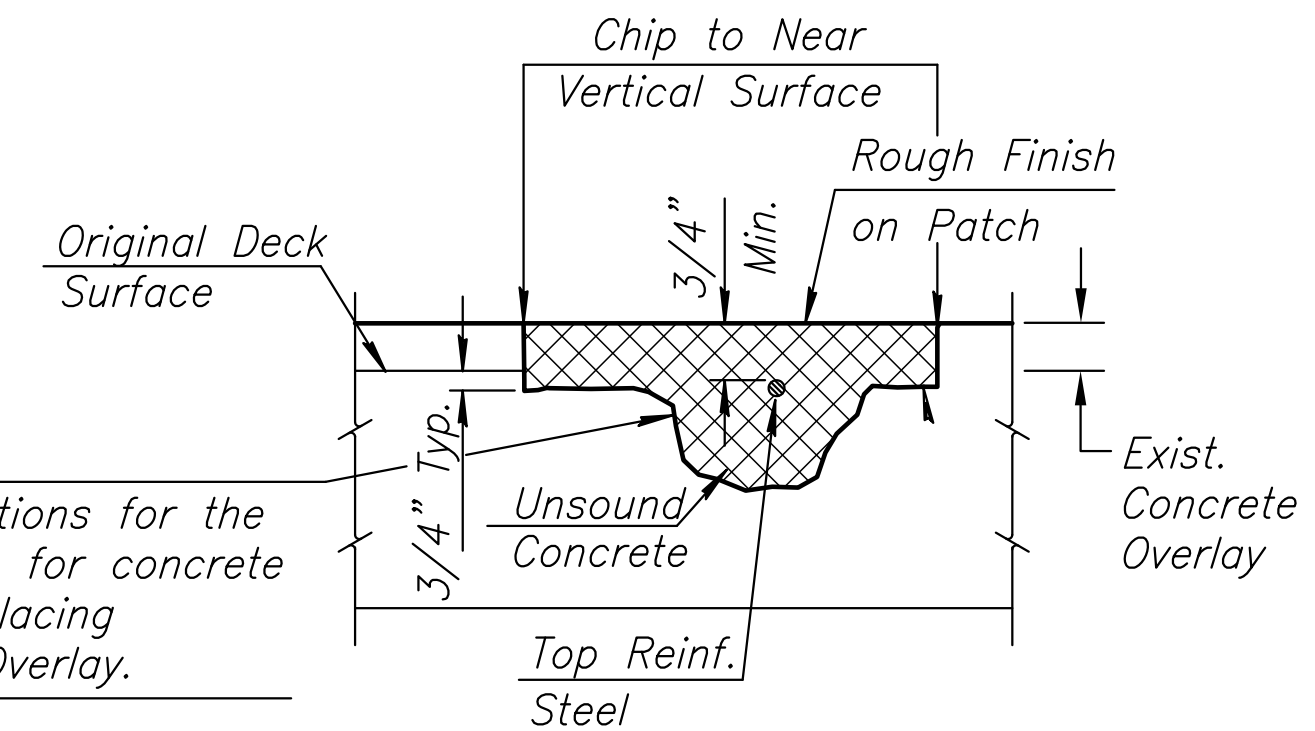

PARTIAL DEPTH PATCHING
(Paid for as "Area Prepared for Patching")

DECK PATCHING DETAILS

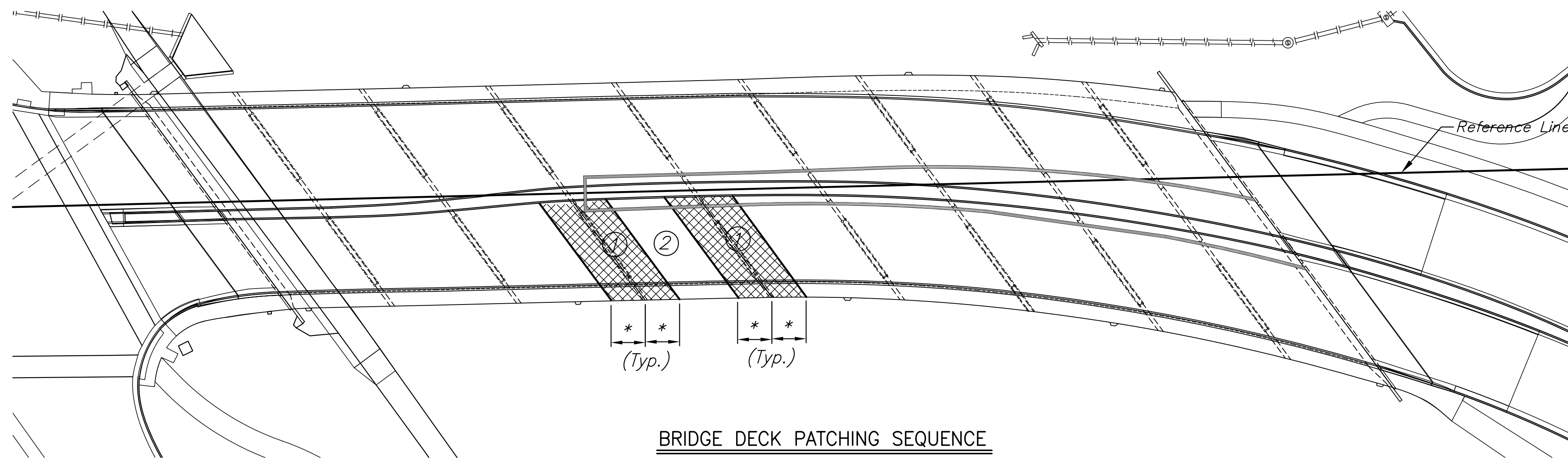

BRIDGE DECK PATCHING SEQUENCE

* Span length/4 or as directed by the Engineer

PATCHING SEQUENCE:

The concrete removal shall be completed in stages, beginning with removal of deteriorated concrete in Area ①. If more than 15 longitudinal bars in Area ① are debonded for a distance of greater than 4 feet along the bars, the concrete removal shall stop and the patch area filled with Gr. 4.0 Concrete (AE). The patch shall cure a minimum of 3 days before concrete removal resumes in that area. Following the completion of work in Area ①, concrete removal may begin in Area ②. Concrete removal shall not begin in an Area ② until the patching concrete in adjacent Area ① has cured a minimum of 3 days. Fully debonded bars in Area ① shall be limited to a 4'x8' maximum patch size. All patching and overlay shall cure according to the Specifications prior to allowing traffic on that lane.

LEGEND

■ Areas for Full Depth Patching

MINIMUM REBAR SPLICE LENGTHS *		
Bar Size	Gr. 40	Gr. 60
#4	12"	16"
#5	13"	20"
#6	16"	24"
#7	20"	30"
#8	26"	39"
#9	33"	49"
#10	42"	62"
#11	52"	77"

* Lap lengths are based on a Class B Splice. Use the min. splice length corresponding to the grade of existing reinforcing in the deck.

NOTE: If splicing epoxy coated reinforcing steel, increase the above splice lengths by 20%.

SUMMARY OF QUANTITIES		
ITEM	UNITS	QUANTITY
Area Prepared for Patching	S.Y.	1,301
Area Prepared for Patching (Full Depth)	S.Y.	59
Reinforcing Steel, Gr. 60 (Repair) △	Lbs.	10,214

△ Reinforcing provided in various sizes and lengths for bridge repair.

©2013
 MKEC Engineering
 All Rights Reserved
 www.mkec.com
 These drawings and their contents, including, but not limited to, all concepts, designs, & ideas are the exclusive property of MKEC Engineering (MKEC), and may not be used or reproduced in any way without the express consent of MKEC.

DECK PATCHING DETAILS		
PROJECT NO.	472-84922	
DATE	04/05/2016	
SCALE	NONE	
DESIGNED	DRAWN	CHECKED
HWL	DPG	KJS
NO.	REVISION	DATE