

NOTE: USE THERMOPLASTIC FROM STA 3+017.50 TO STA 3+281.35 (ASPHALT SURFACE)
 USE COLD PLASTIC FROM STA 3+281.35 TO STA 3+470.04 (CONCRETE SURFACE)
 USE THERMOPLASTIC FROM STA 3+470.04 TO STA 3+538.98 (ASPHALT SURFACE)

FHWA REG NO.	STATE	PROJECT NO.	YEAR	SHEET NO.	TOTAL SHEETS
7	KANSAS	87 N-0198-01	2001	46	82

FED. AID NO. - CMQ-N019(B01)

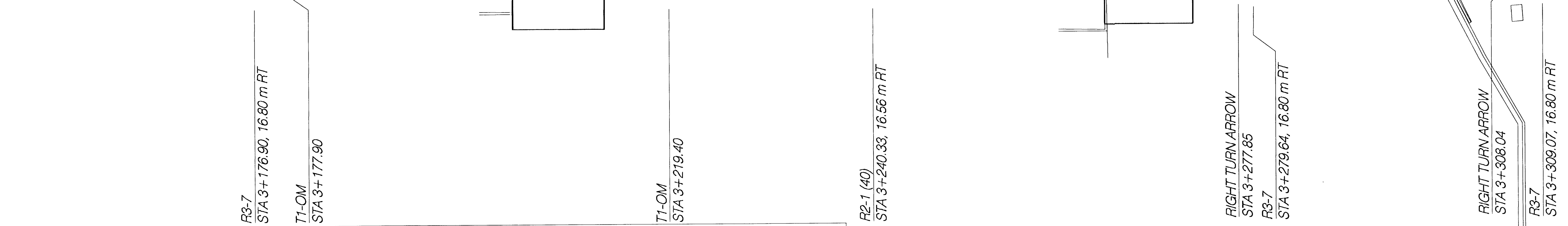
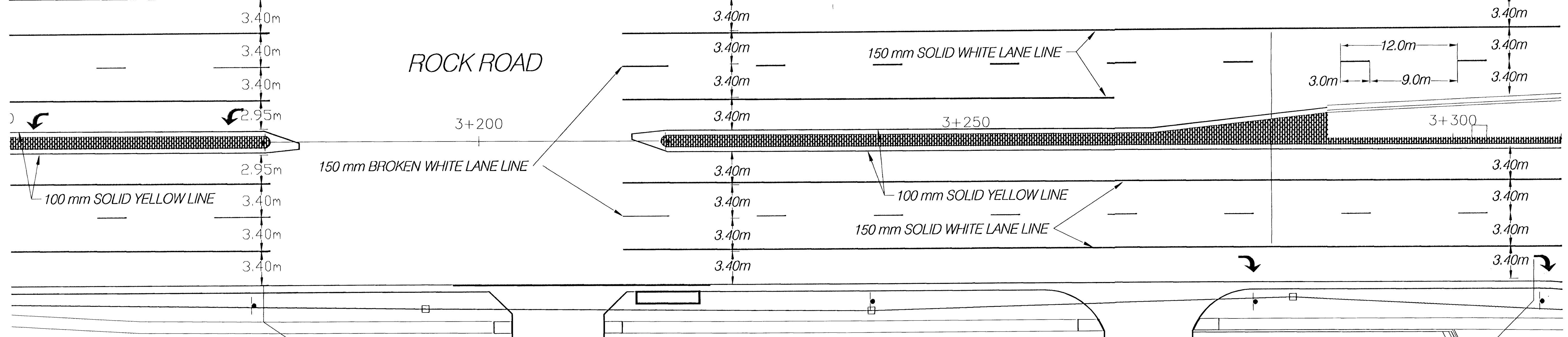
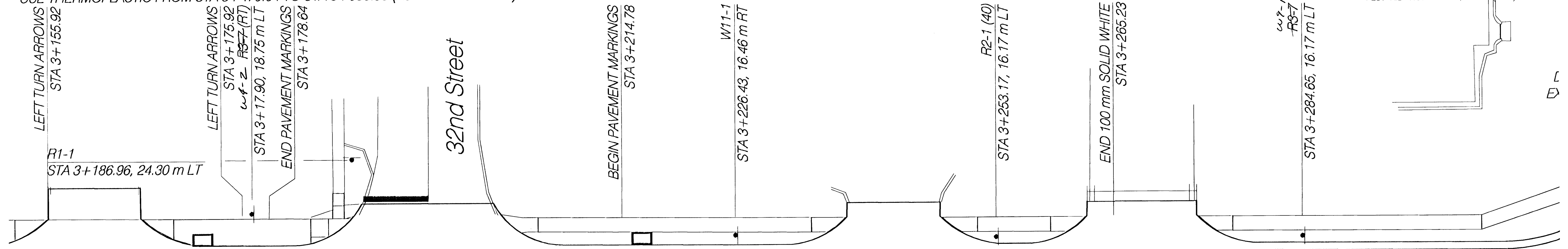

SIGN LEGEND		
R1-1	STOP	1
R2-1 (40)	SPEED LIMIT (40 MPH)	2
R3-7	RIGHT LANE MUST TURN RIGHT	5
T1-OM	TYPE I OBJECT MARKER	2
W11-1	BICYCLE CROSSING	1

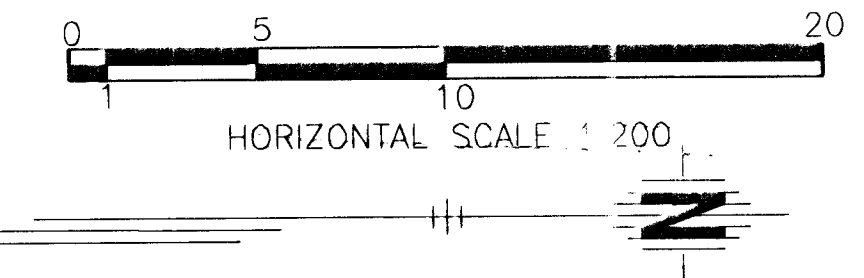

ROCK ROAD
PAVEMENT MARKINGS & SIGNING
STA. 3+150 - 3+311

HWS Consulting Group, Inc.
 Manhattan Office
 3206 Kimball Avenue
 Manhattan, KS 66503
 Phone: (785) 539-2202
 Fax: (785) 539-2393

Designed By: JWH
 Drawn By: BJD
 Checked By: JWH
 Date: 7/3/01
 Job No. 55-70-2003

ROCK ROAD PMK.DWG