



Dudley Williams and Associates, PA
 230 Laura • Suite 200 • Wichita, KS 67211-1514
 316-267-7591 • www.dwaasc.com



COMMERCE RAIL YARD PARKING LOT
 STAGE COVER AND FOUNDATIONS
 WICHITA, KANSAS

PROJECT NO.
16116.00
 DATE
August 27, 2016

S2

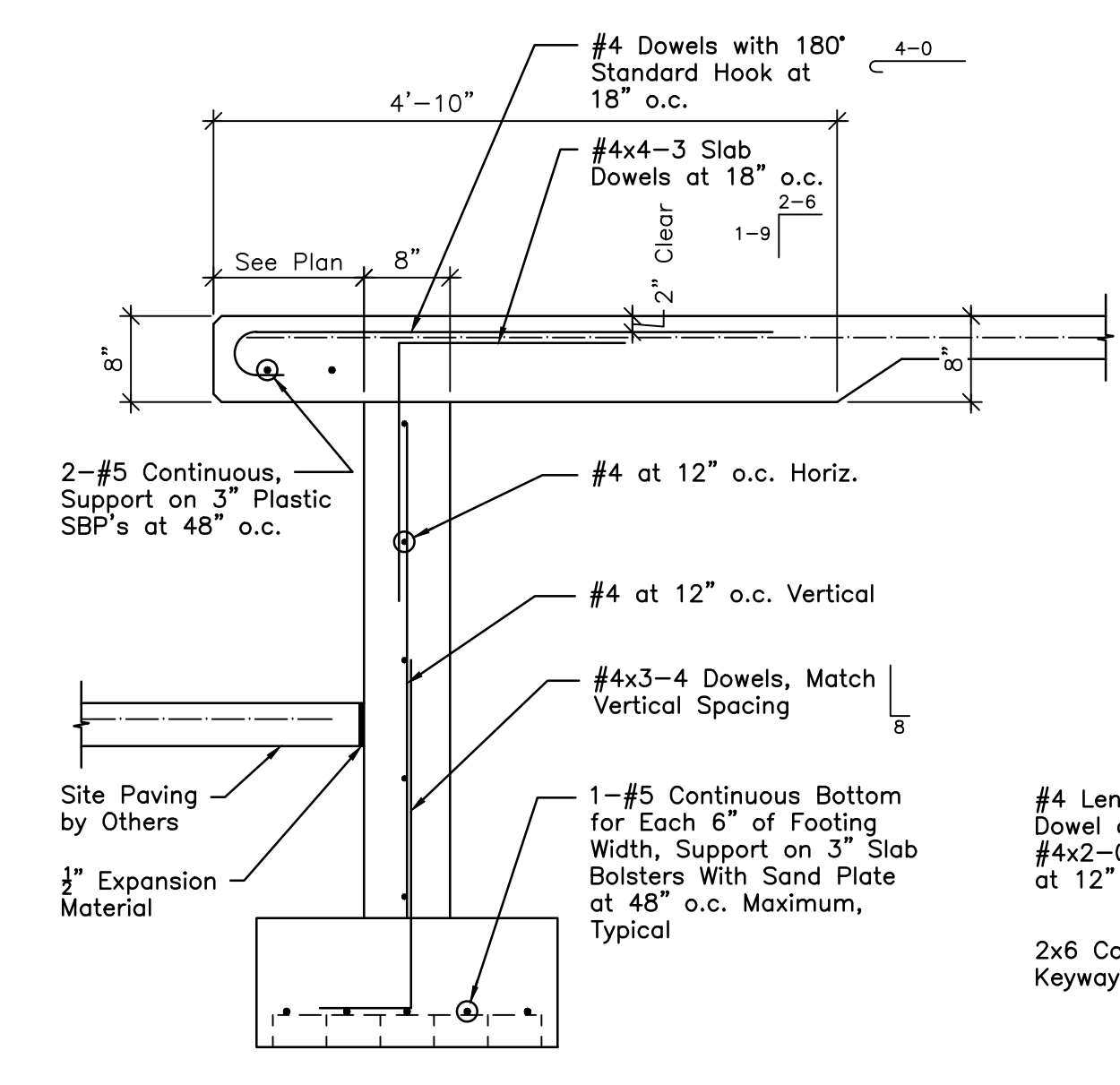

1 SECTION
1/2" = 1'-0"

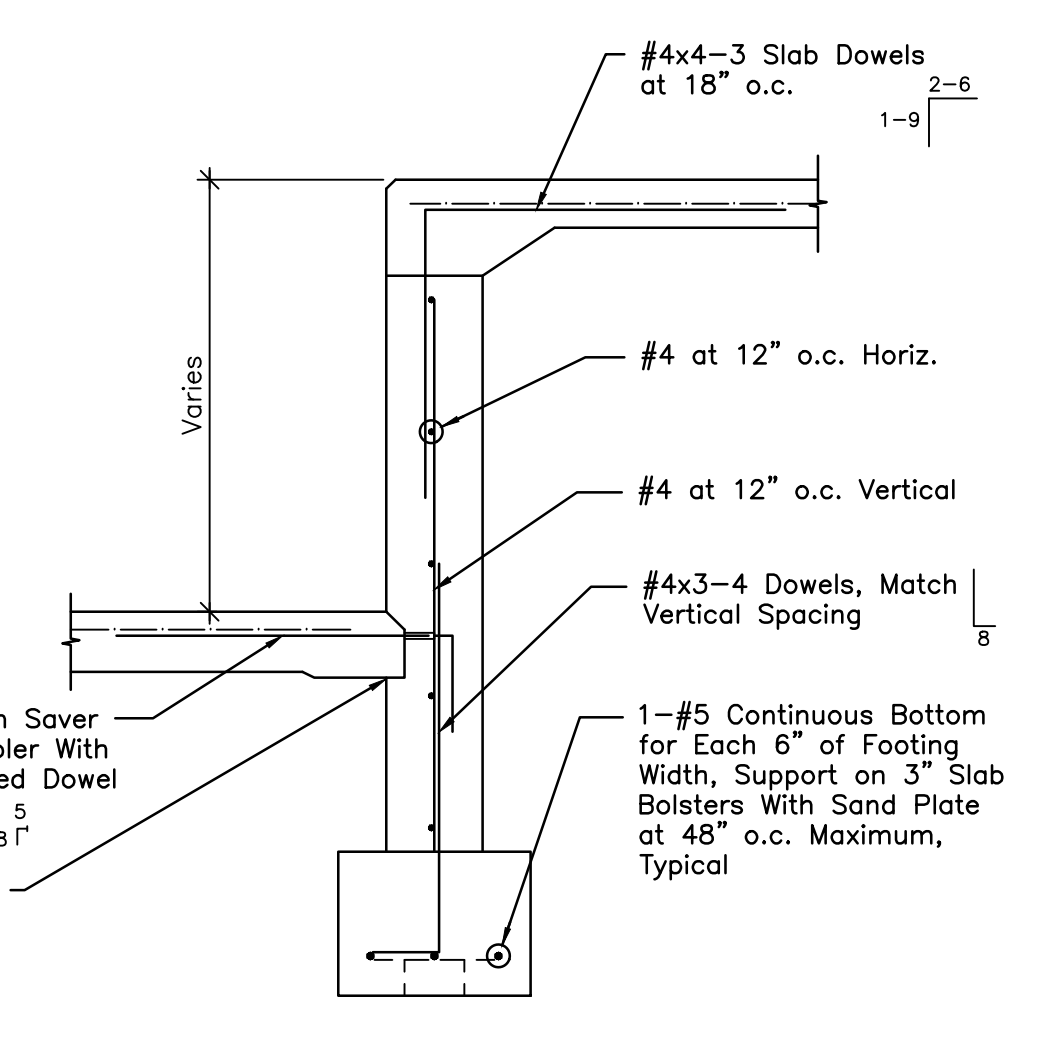

2 SECTION
1/2" = 1'-0"

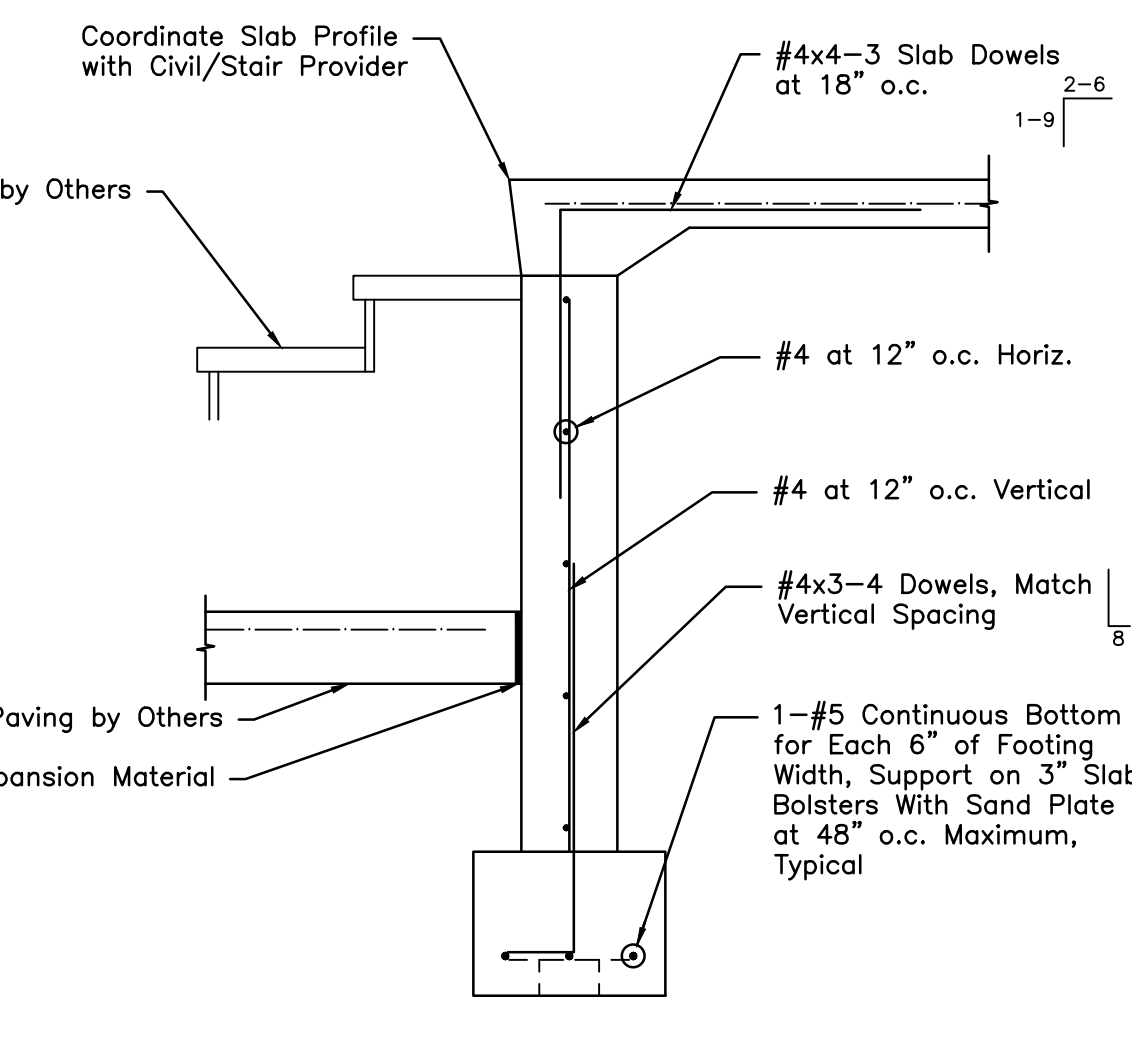

3 SECTION
1/2" = 1'-0"

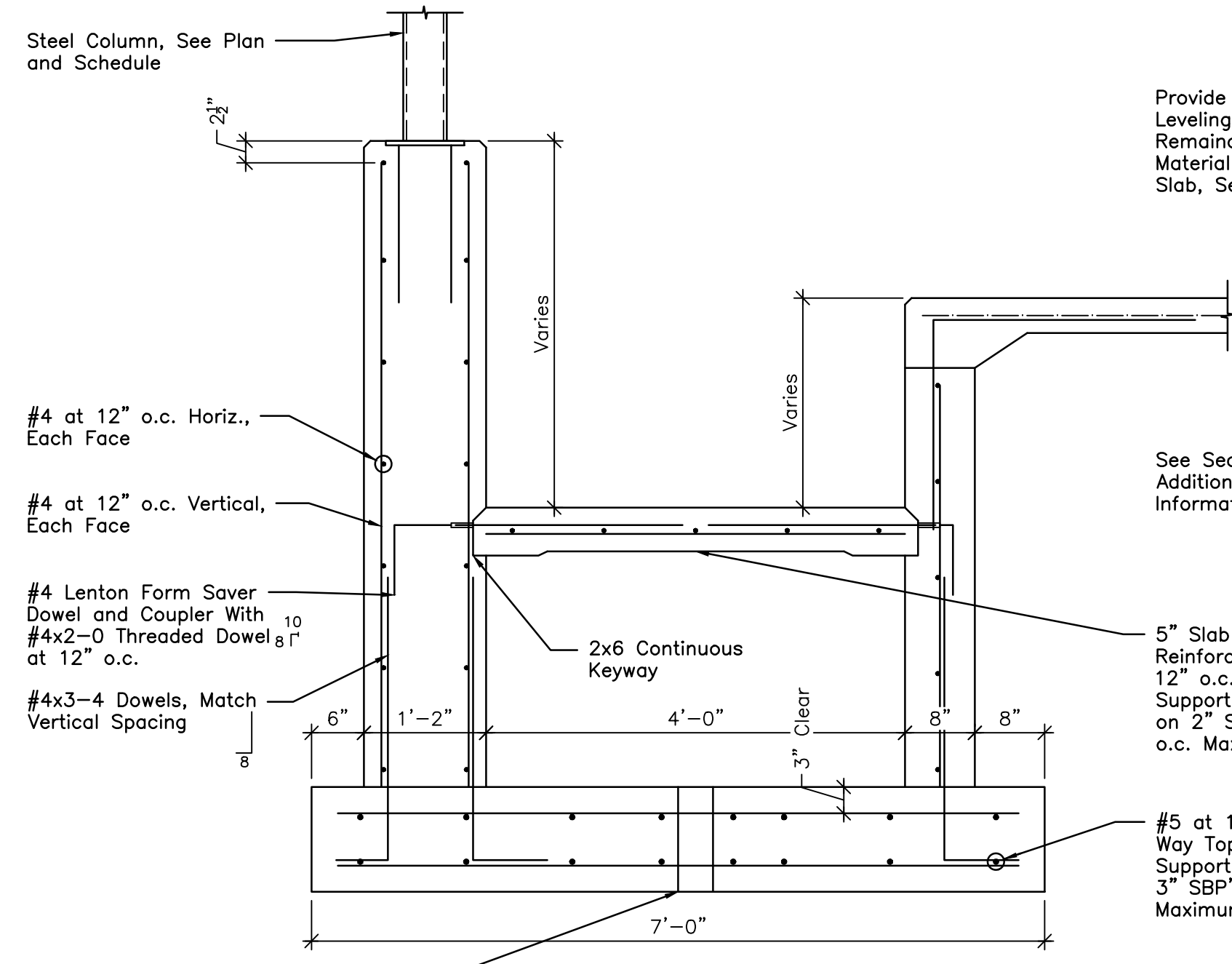

4 SECTION
1/2" = 1'-0"

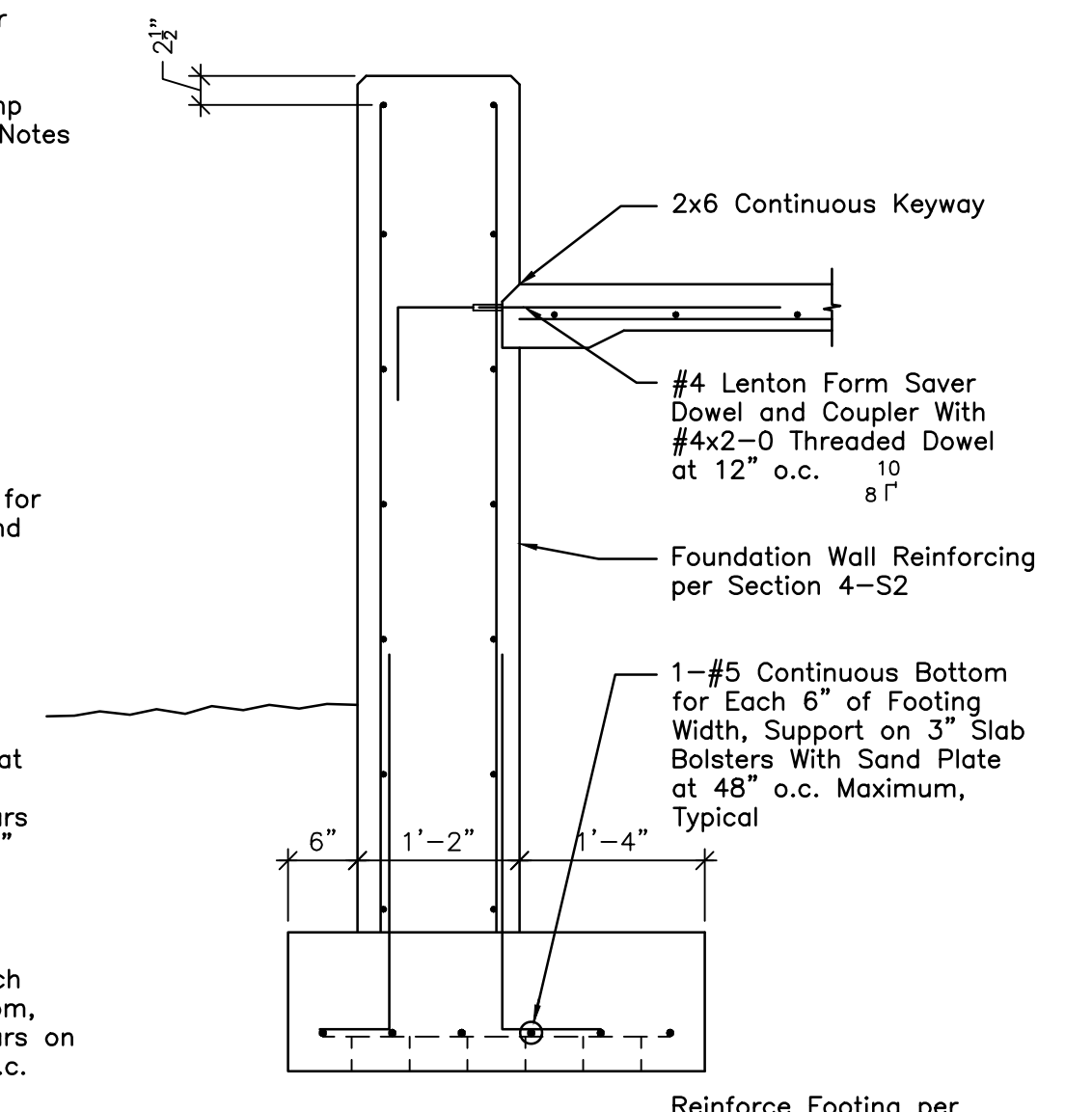

5 SECTION
1/2" = 1'-0"

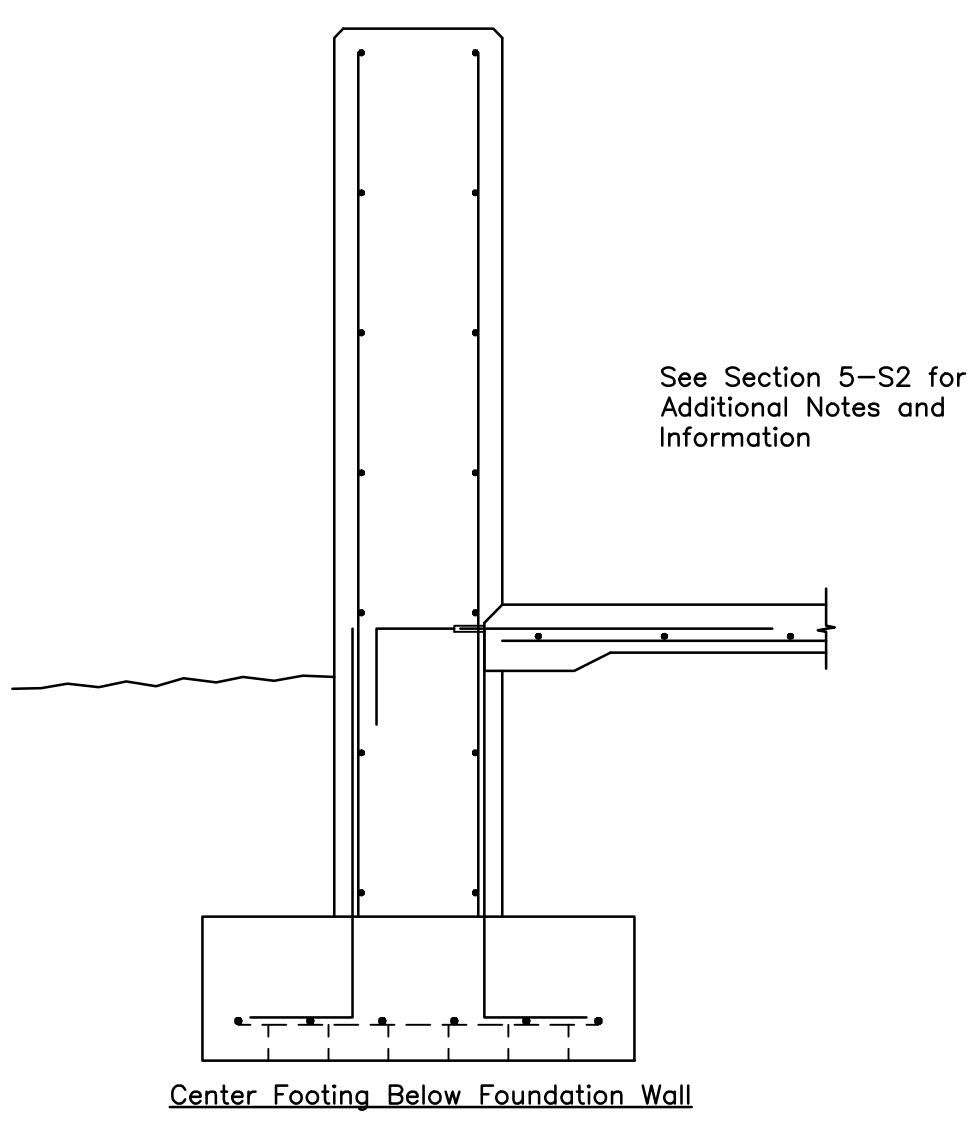

6 SECTION
1/2" = 1'-0"

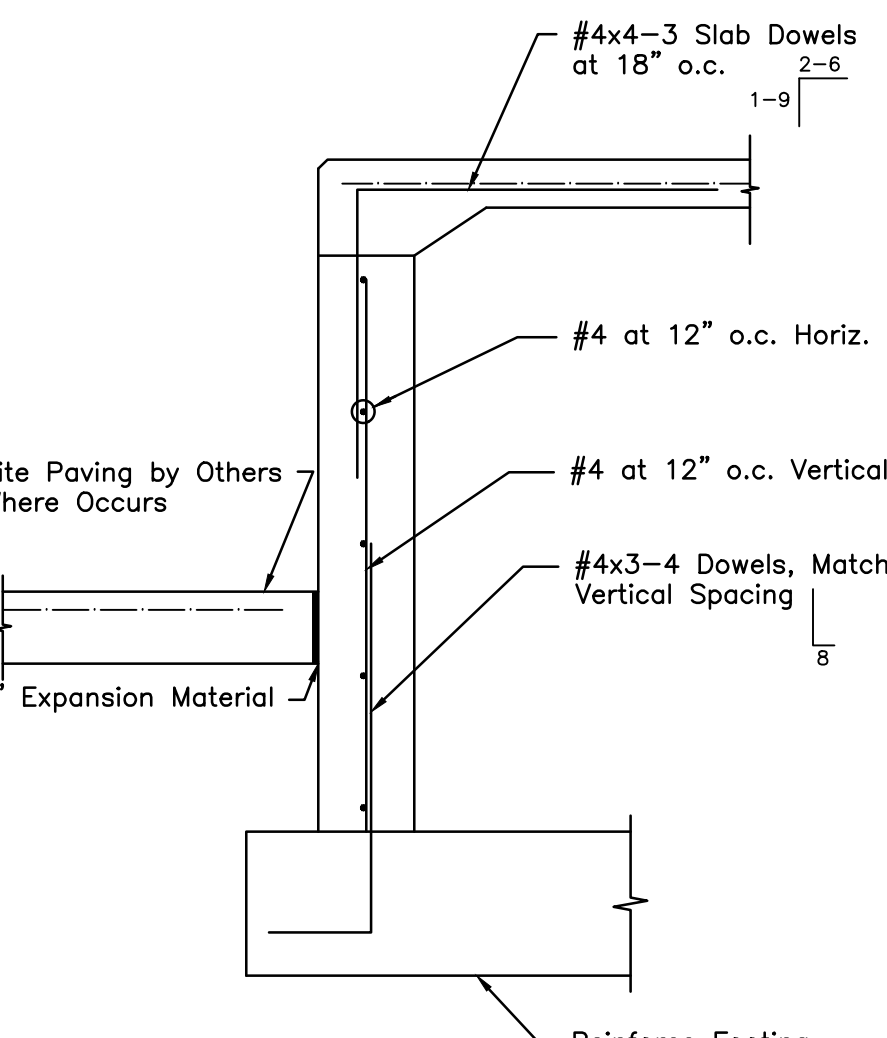

7 SECTION
1/2" = 1'-0"

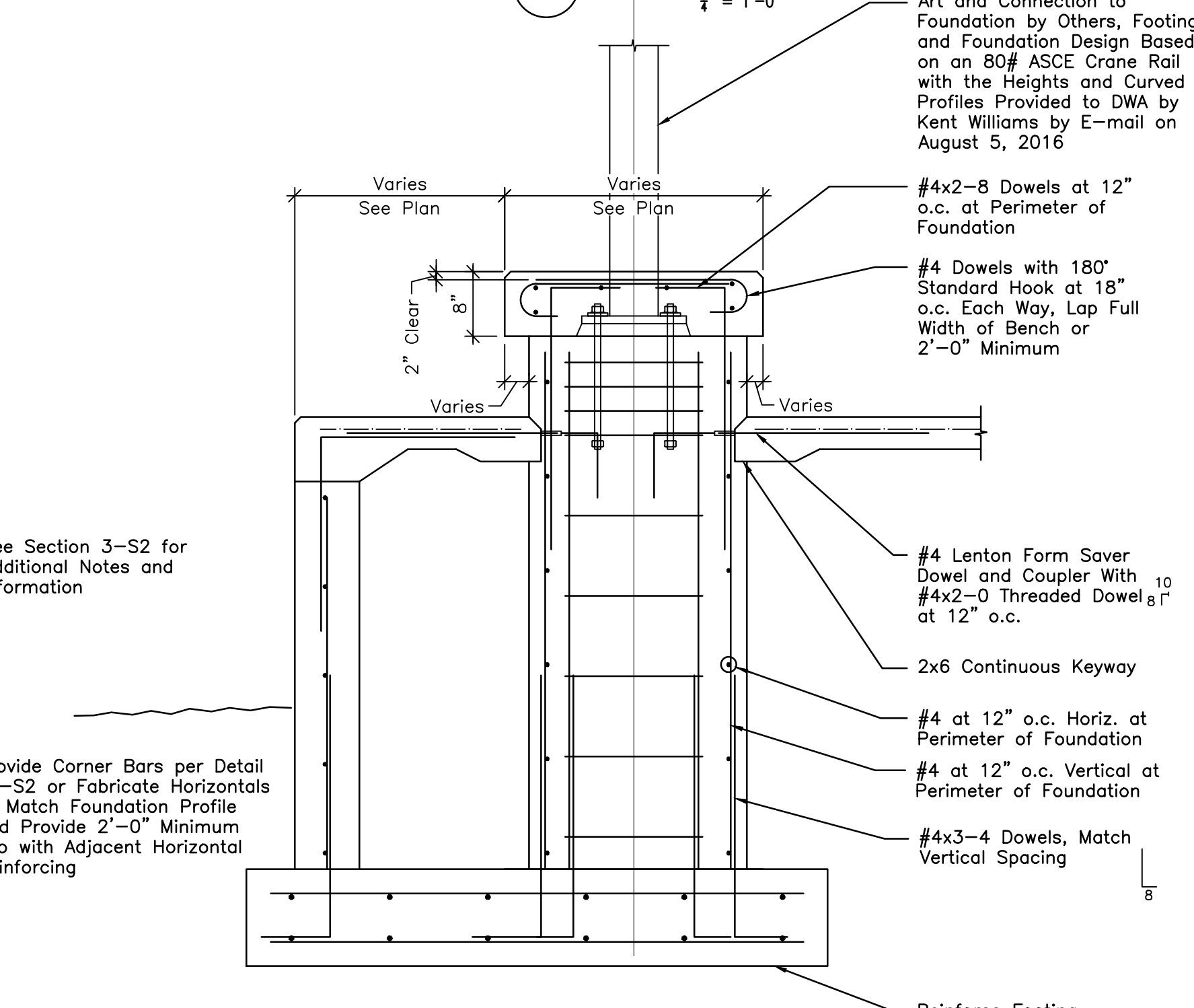

8 SECTION
1/2" = 1'-0"

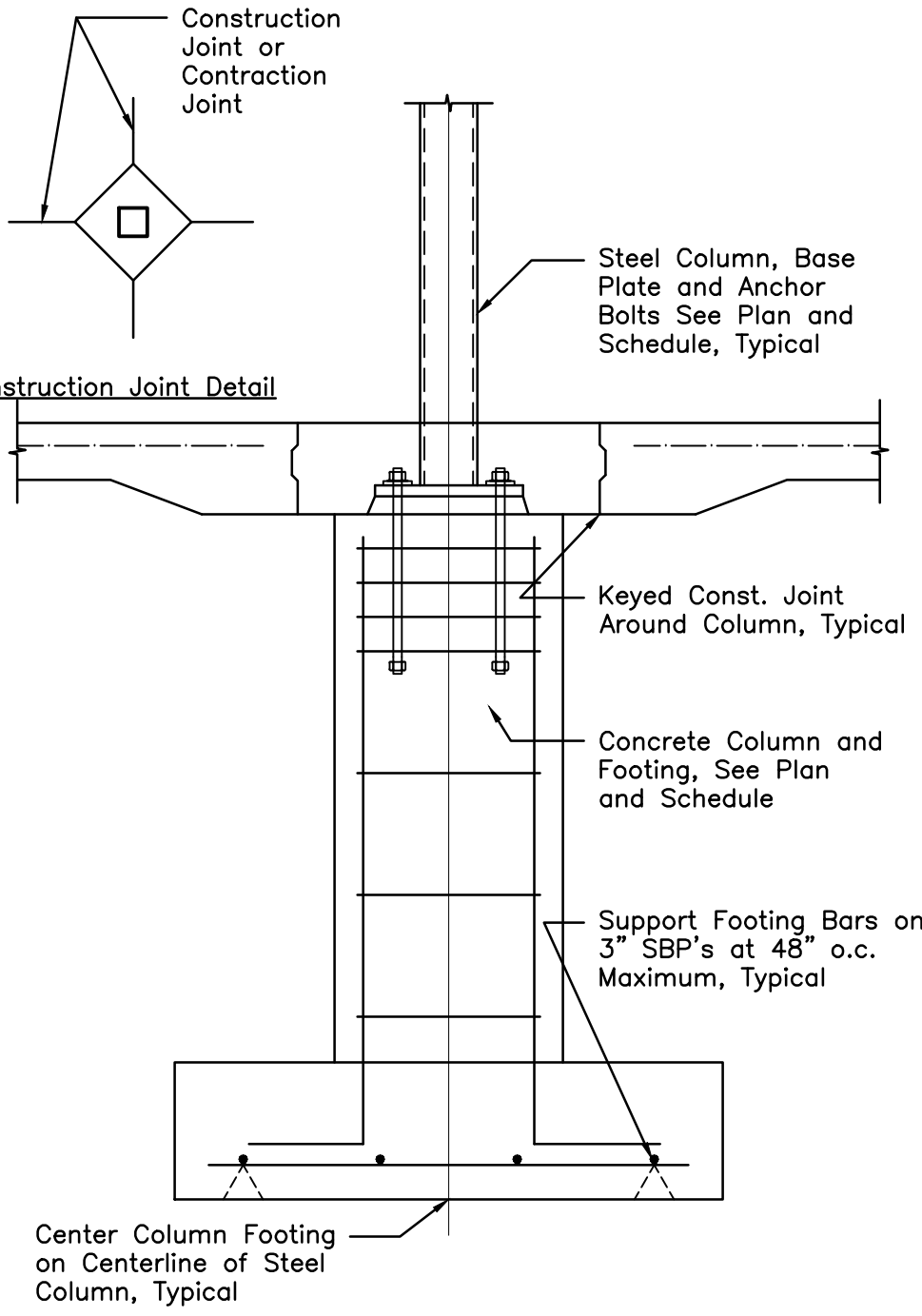

9 SECTION
1/2" = 1'-0"

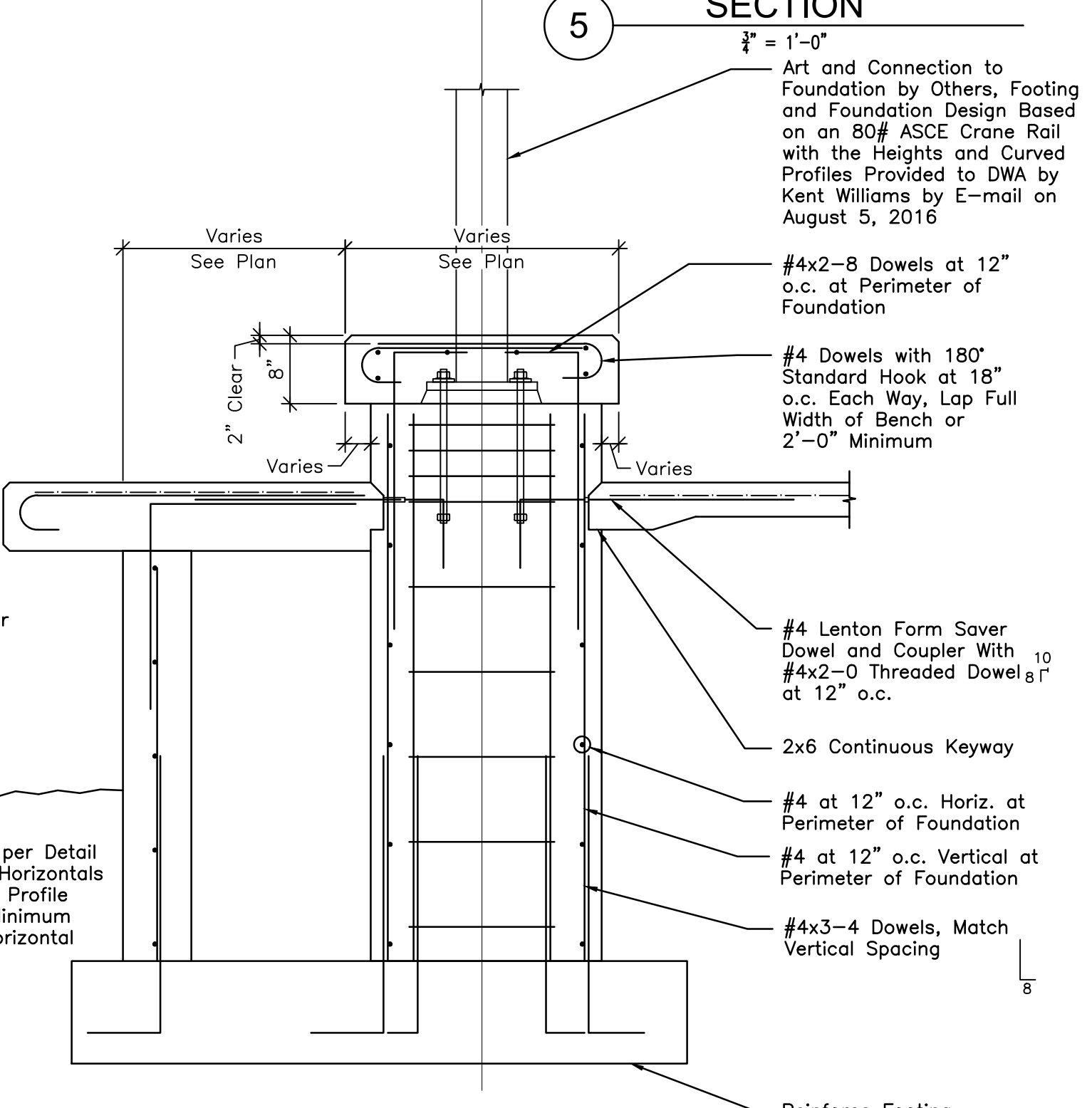

10 SECTION
1/2" = 1'-0"

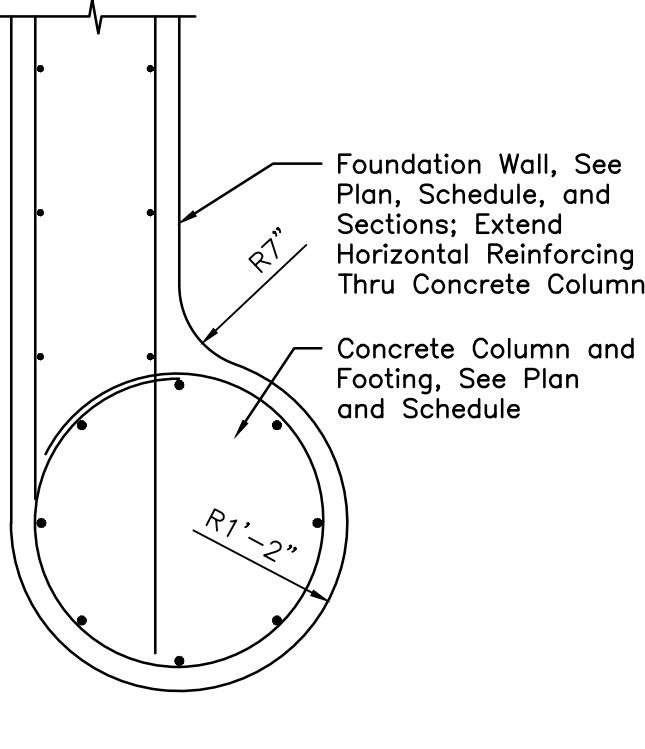

11 PLAN VIEW DETAIL
1/2" = 1'-0"

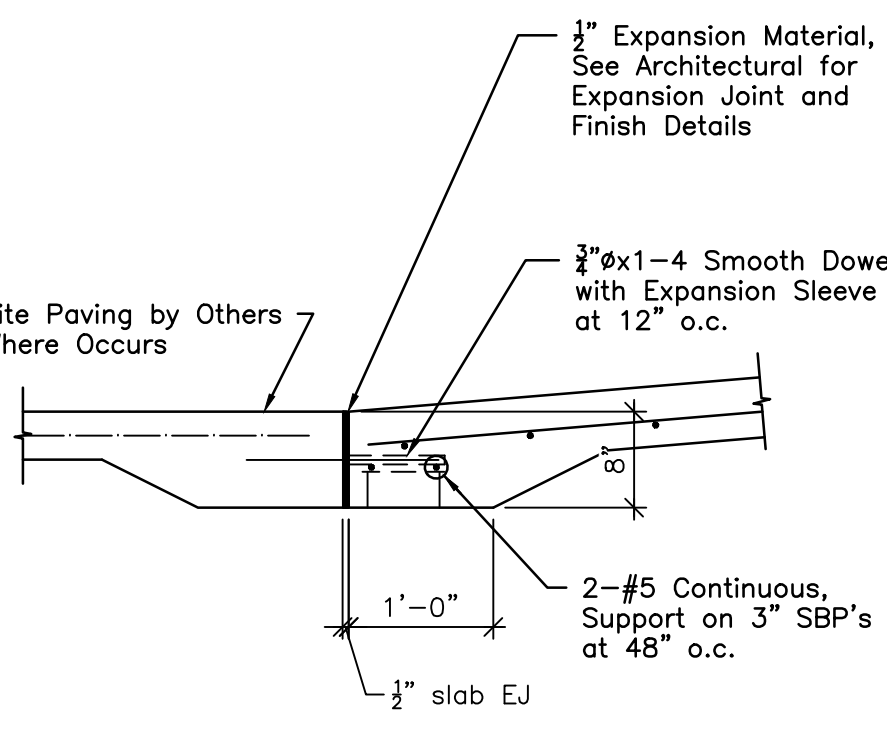

12 SECTION
1/2" = 1'-0"

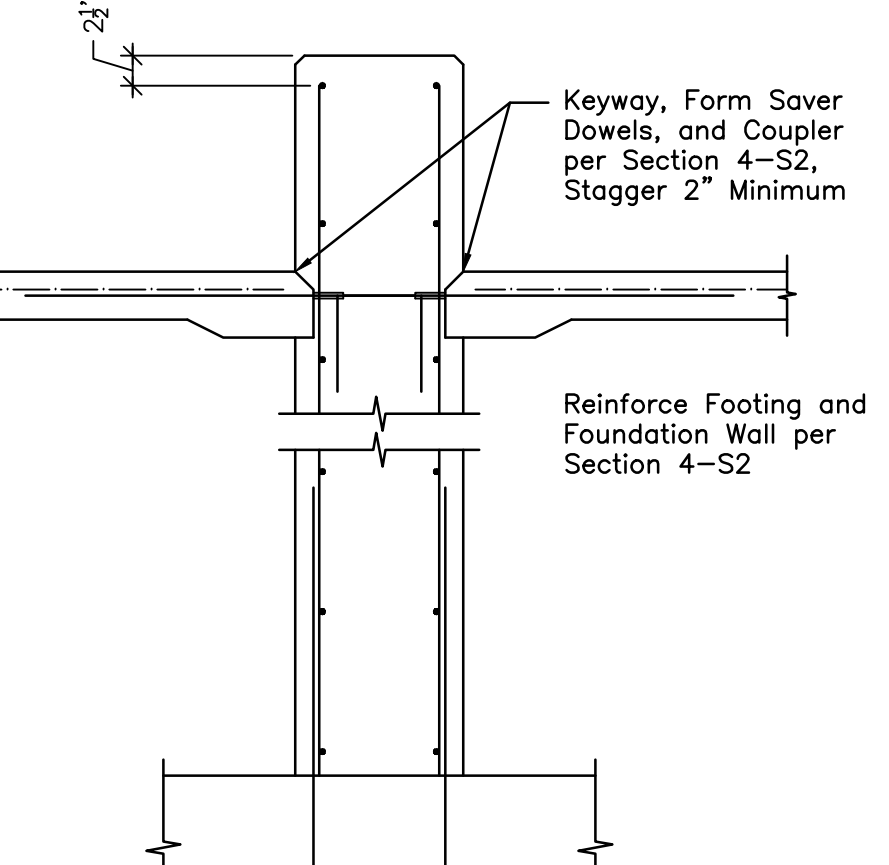

13 SECTION
1/2" = 1'-0"

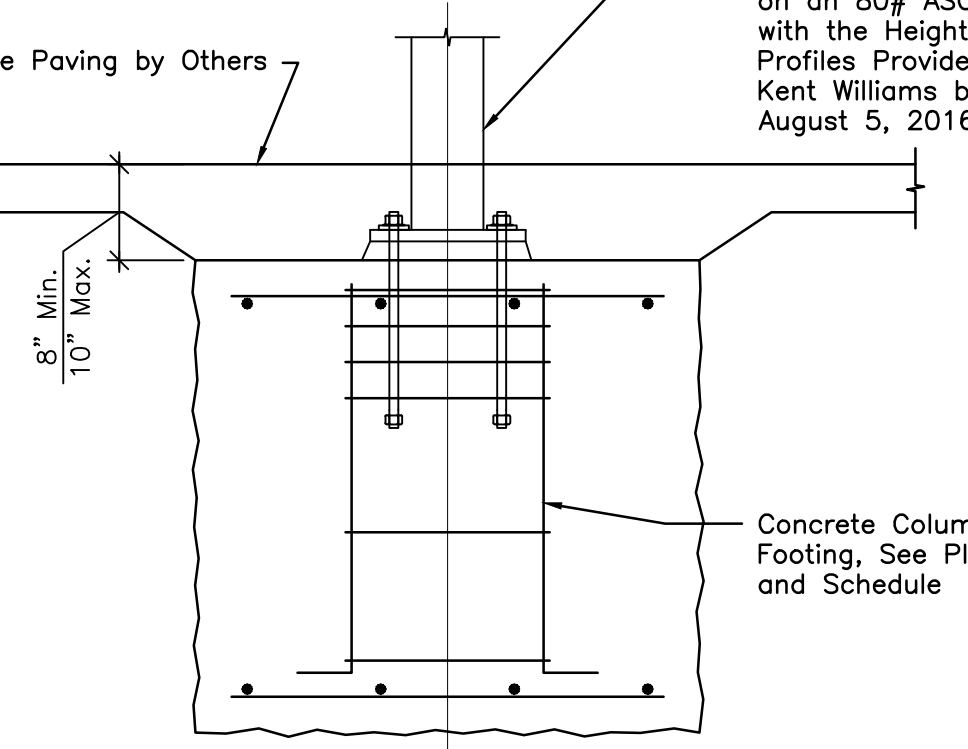

14 SECTION
1/2" = 1'-0"

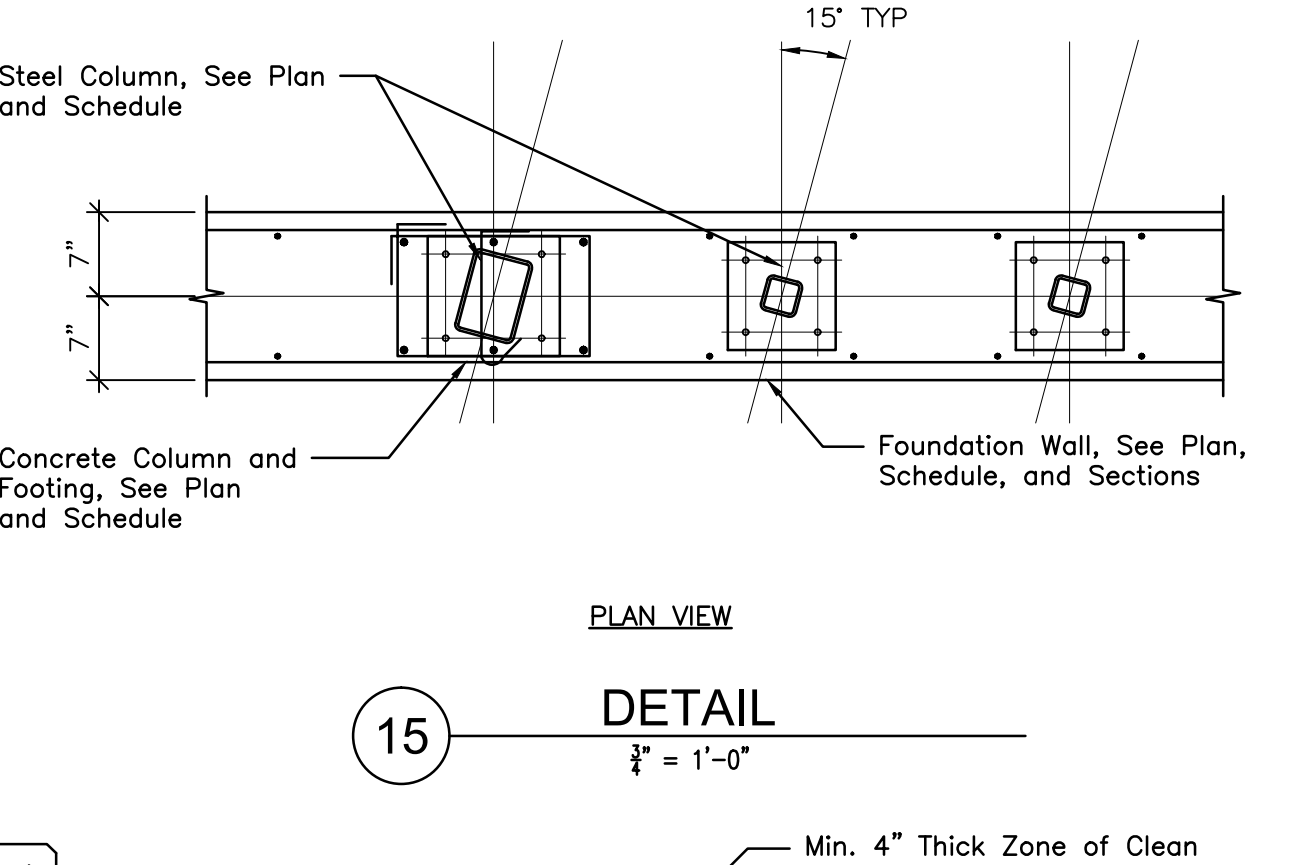

15 PLAN VIEW DETAIL
1/2" = 1'-0"

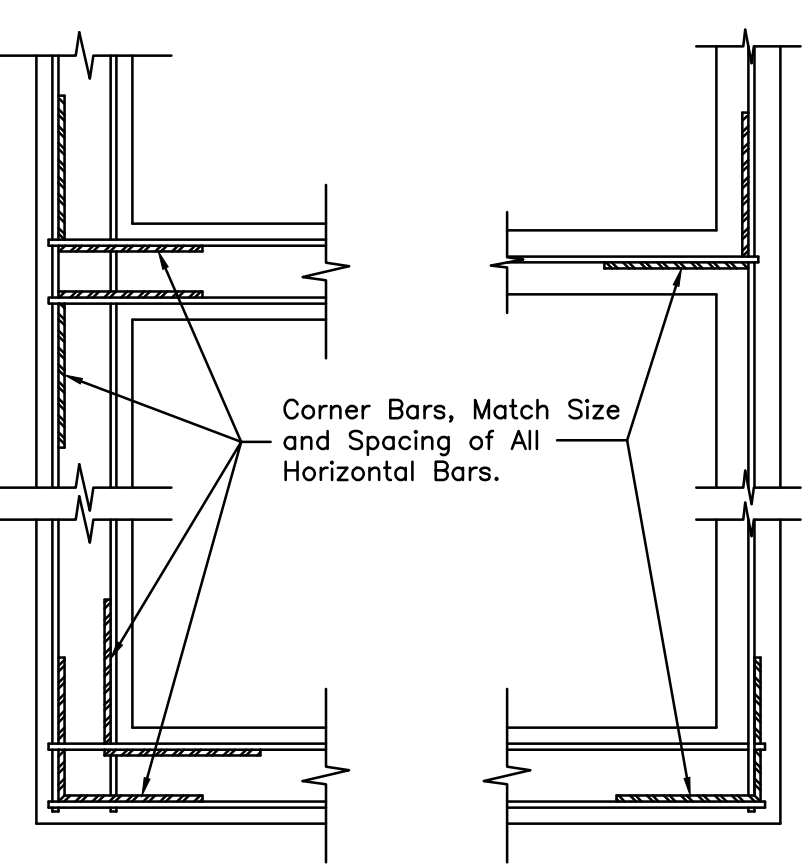

16 CORNER BAR DETAIL
No Scale

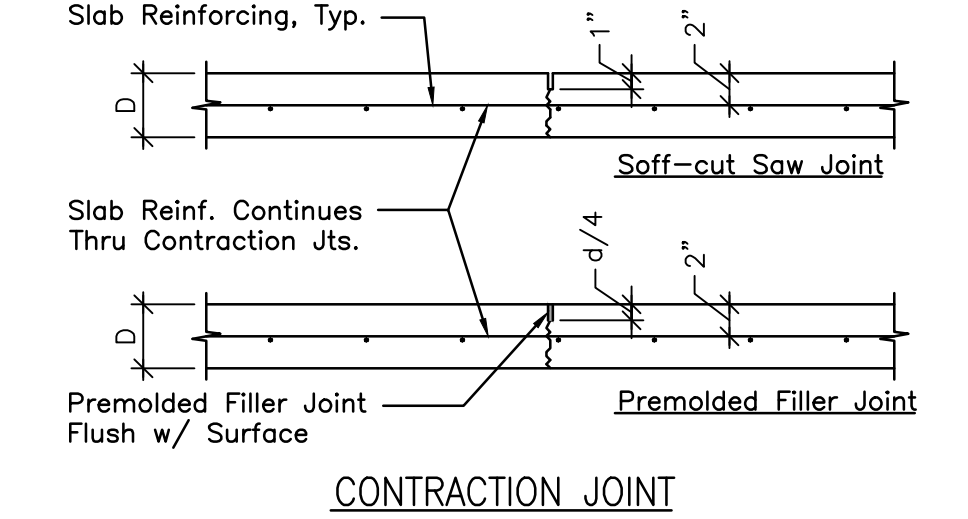

17 TYP. SLAB JOINT DETAILS
No Scale

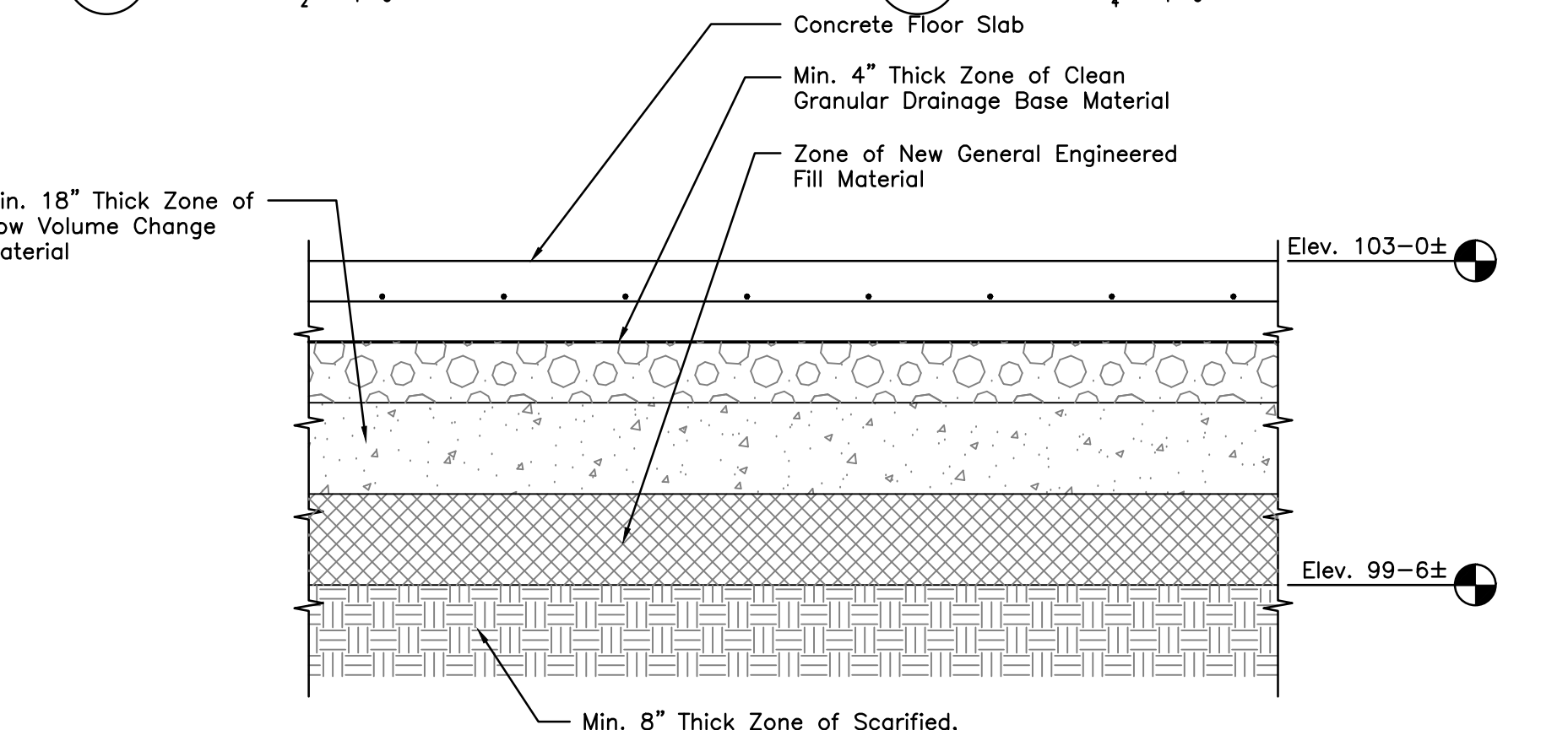

18 TYP. EARTHWORK DETAIL
No Scale

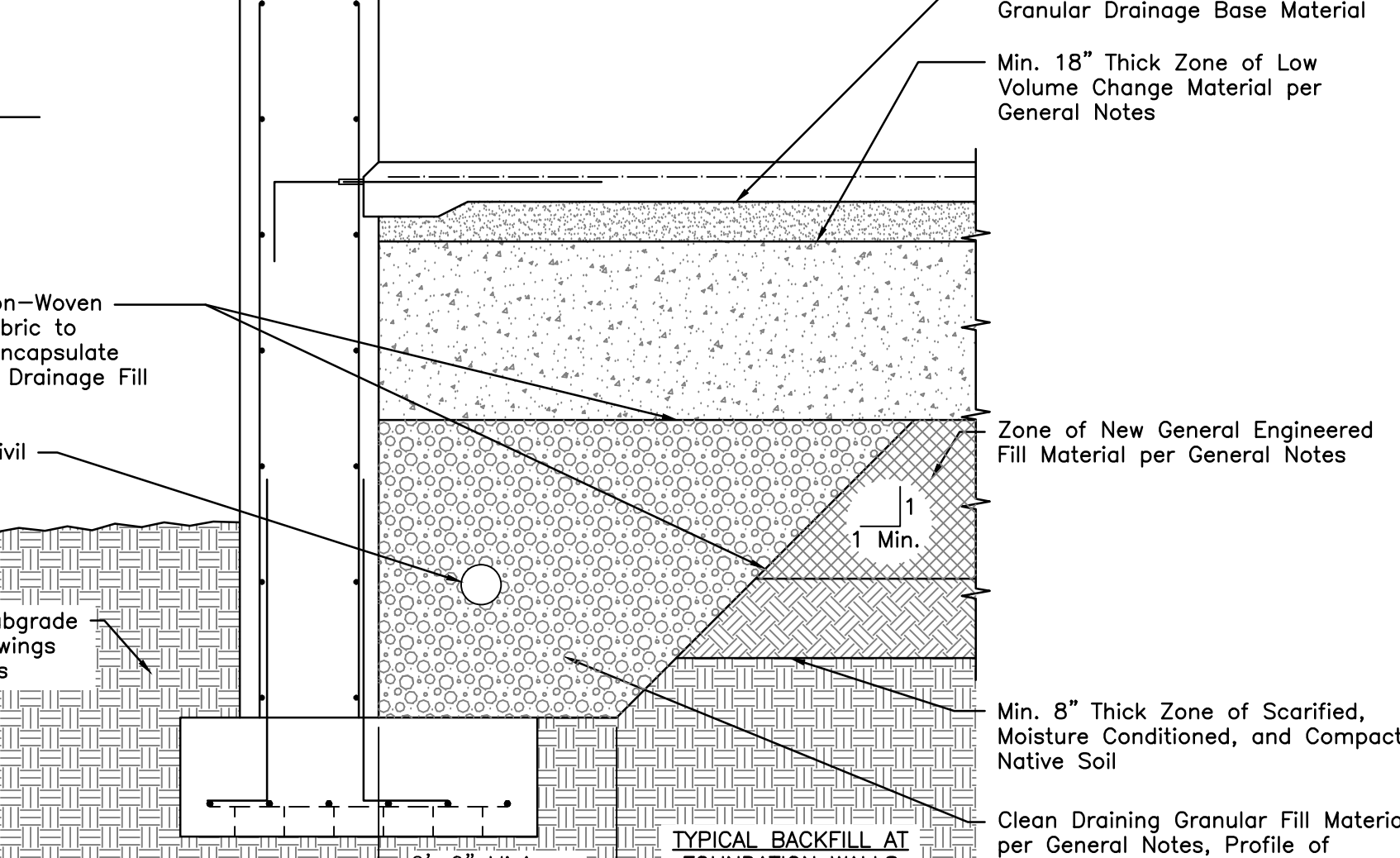

19 TYP. BACKFILL DETAIL
No Scale

Note: All saw cut joints in interior floor slabs shall use Soft-cut or early entry dry-cutting sawing system.