

DRUMS AND TRIM LINE CHANNELIZERS SHALL BE RETROREFLECTORIZED FULL CIRCUMFERENCE WITH AT LEAST TWO ORANGE AND TWO WHITE 6" TO 8" WIDE STRIPES. ADDITIONAL STRIPES MAY BE NON-REFLECTIVE. IF THERE ARE NON-REFLECTIVE SPACES BETWEEN ADJACENT STRIPES, THEY SHALL BE NO MORE THAN 2" WIDE.

ALL RETROREFLECTIVE STRIPES ON DRUMS SHALL BE TYPE III HIGH PERFORMANCE SHEETING. THE WHITE STRIPES ON TRIM LINE CHANNELIZERS SHALL BE TYPE III HIGH PERFORMANCE SHEETING. THE ORANGE STRIPES ON TRIM LINE CHANNELIZERS SHOULD BE FLUORESCENT ORANGE PRISMATIC SHEETING; HOWEVER, TRIM LINE CHANNELIZERS PURCHASED PRIOR TO NOVEMBER 1, 2000, MAY HAVE STRIPES OF ORANGE TYPE III HIGH PERFORMANCE SHEETING, PROVIDED THE DEVICES ARE SPACED ACCORDING TO THE CHART BELOW. PROJECTS LET AFTER JANUARY 1, 2002, WILL REQUIRE THAT THE ORANGE STRIPES ON ALL TRIM LINE CHANNELIZERS BE FLUORESCENT ORANGE PRISMATIC SHEETING.

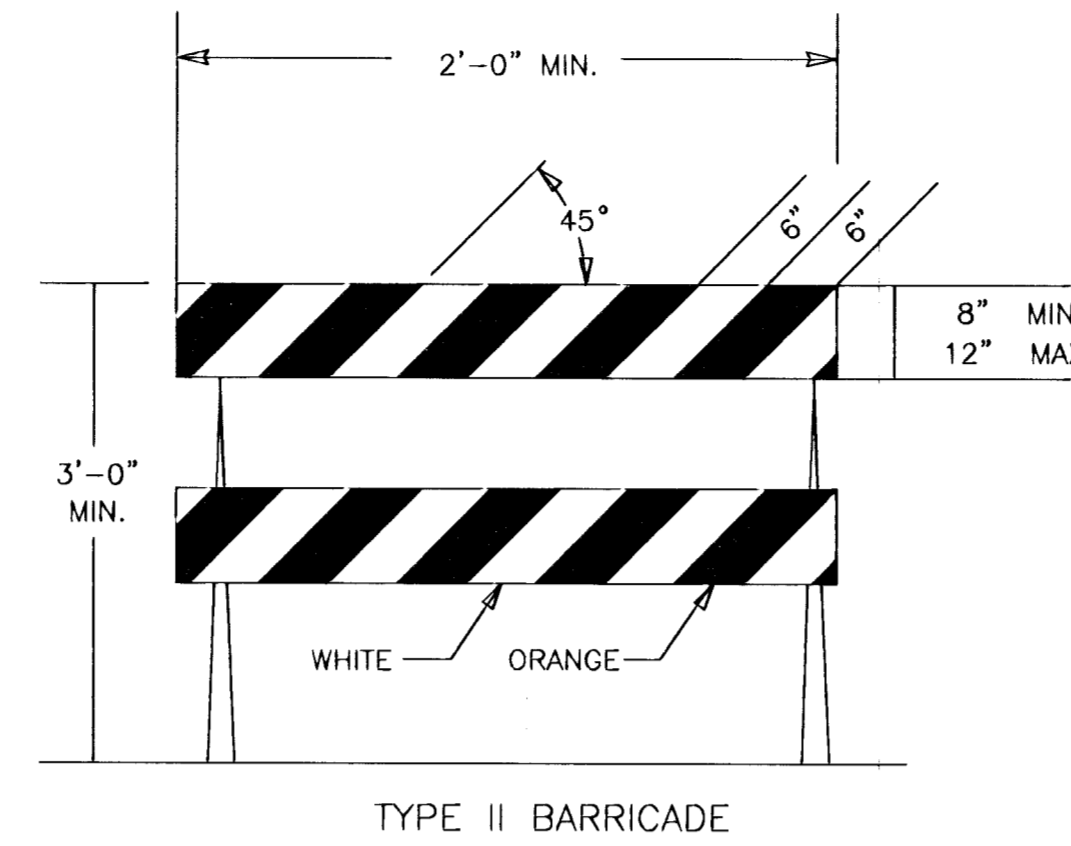

FOR WOODEN BARRICADES, NOMINAL LUMBER DIMENSIONS WILL BE SATISFACTORY.

FOR RAILS LESS THAN 3'-0" LONG, 4" WIDE STRIPES MAY BE USED.

THE ENTIRE AREA OF BARRICADE RAILS, BOTH FRONT AND BACK, SHALL BE FULLY REFLECTORIZED WITH TYPE III HIGH PERFORMANCE RETROREFLECTIVE SHEETING.

BARRICADES USED ON ROADWAYS WITH SPEED LIMITS OF 45 MPH OR MORE SHALL HAVE A MINIMUM OF 1.9 SQ FEET OF RETROREFLECTIVE AREA FACING TRAFFIC.

THE STRIPES SHALL SLOPE DOWNWARD TO THE TRAFFIC SIDE FOR CHANNELIZATION.

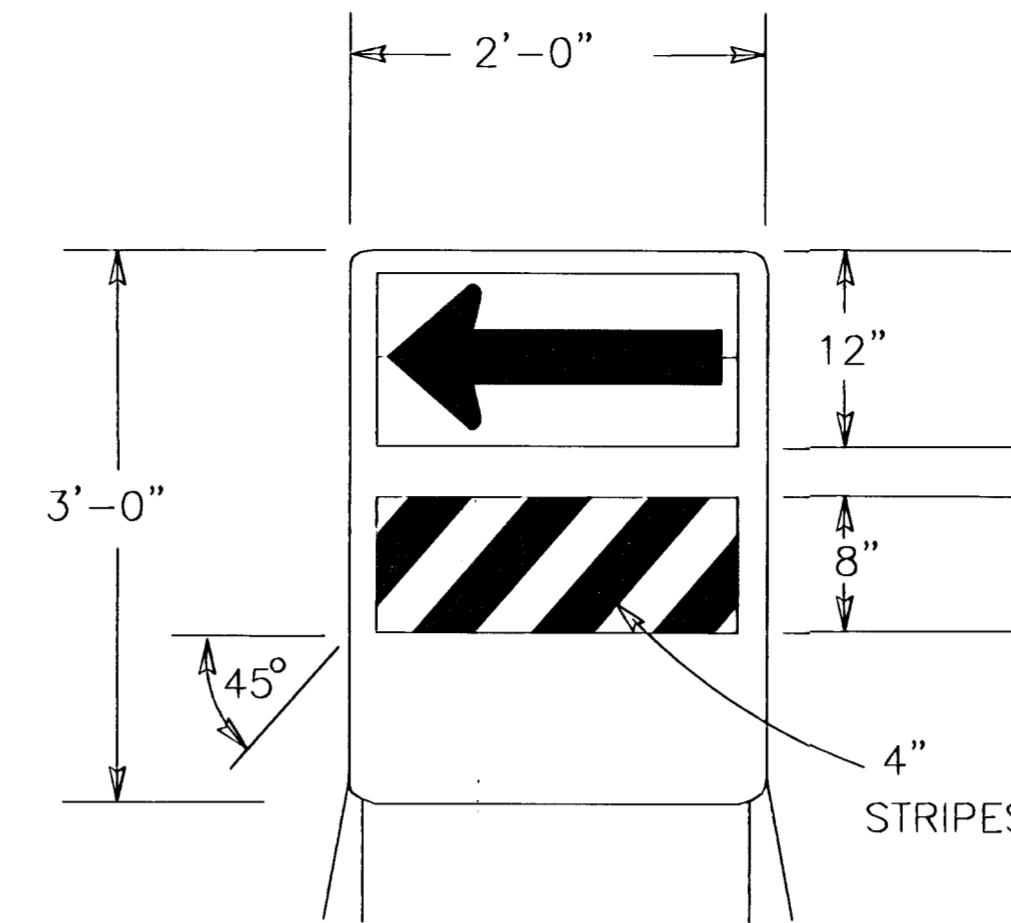

DIRECTION INDICATOR BARRICADE

THE ARROW PANEL SHALL BE BLACK ON FLUORESCENT ORANGE PRISMATIC GRADE SHEETING. THE STRIPES SHALL BE ORANGE AND WHITE TYPE III HIGH PERFORMANCE RETROREFLECTIVE SHEETING SLOPING DOWNWARD IN THE DIRECTION TRAFFIC IS TO PASS.

THE DIRECTION INDICATOR BARRICADE SHOULD BE USED IN SERIES TO DIRECT THE MOTORIST INTO THE INTENDED LANE OF TRAVEL. THE ARROW PANEL SHOULD NOT BE VISIBLE TO OPPOSING TRAFFIC.

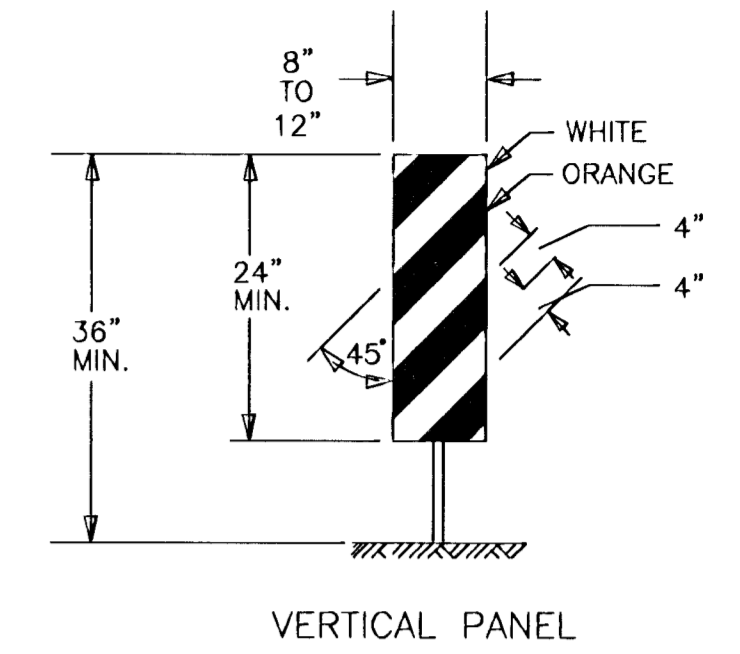

VERTICAL PANEL

THE ENTIRE AREA OF VERTICAL PANELS, BOTH FRONT AND BACK, SHALL BE FULLY REFLECTORIZED WITH TYPE III HIGH PERFORMANCE RETROREFLECTIVE SHEETING. VERTICAL PANELS USED ON ROADWAYS WITH A SPEED LIMIT OF 45 MPH OR GREATER SHALL HAVE A MINIMUM OF 1.9 SQ FEET OF RETROREFLECTIVE AREA FACING TRAFFIC. THE STRIPES SHALL SLOPE DOWNWARD TO THE TRAFFIC SIDE FOR CHANNELIZATION.

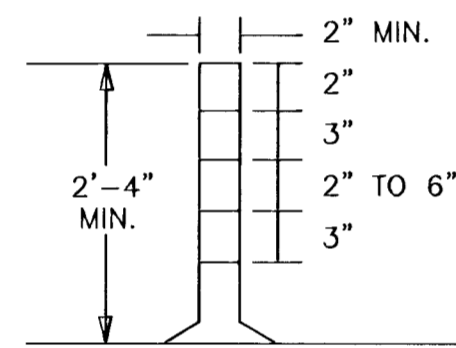

TUBULAR MARKERS

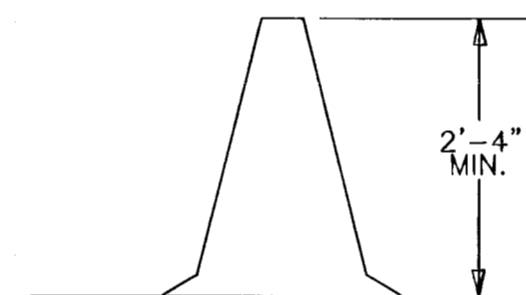

ORANGE CONES

CONES MAY BE USED AS CHANNELIZING DEVICES FOR DAYTIME OPERATIONS ONLY. THEY WILL NOT BE PAID FOR SEPARATELY, BUT WILL BE SUBSIDIARY TO OTHER TRAFFIC CONTROL BID ITEMS. THE ENGINEER MAY REQUIRE THAT CONES BE SUPPLEMENTED BY OTHER TRAFFIC CONTROL DEVICES IN CERTAIN SITUATIONS SUCH AS OPEN TRENCHES.

CHANNELIZER PLACEMENT:

- (A) THE SPACING BETWEEN DEVICES IN THE TAPER SHOULD NOT EXCEED A DISTANCE IN FEET EQUAL TO THE POSTED SPEED LIMIT IN MPH PRIOR TO WORK STARTING.
- (B) THE SPACING BETWEEN DEVICES IN THE WORK ZONE SHOULD NOT EXCEED A DISTANCE IN FEET OF TWO TIMES THE POSTED SPEED LIMIT IN MPH PRIOR TO WORK STARTING.
- (C) WHERE EXISTING CONDITIONS WARRANT, THE ENGINEER MAY REQUIRE A DECREASE IN THE SPACING STIPULATED ABOVE.
- (D) CHANNELIZING DEVICES SHALL BE PLACED FOR OPTIMUM VISIBILITY, NORMALLY AT RIGHT ANGLES TO THE TRAFFIC FLOW.
- (E) CHANNELIZING DEVICES PLACED ALONG SHOULDER EDGES OR IN DROPOFFS SHALL HAVE A MINIMUM OF 2'-0" FROM THE TOP OF THE CHANNELIZING DEVICE TO THE TOP OF THE PAVEMENT.

LOCATION	CROSS-DIVERS	DIVERSTIONS	TANGENTS	TAPERS	RAMPS	HEAD TO HEAD	OBJECT ID.
DRUMS	YES	YES	YES	YES	YES	(1)	YES
TRIM LINES	(2)	(2)	(2)	(2)	(2)	(1,2)	YES
PORTABLE VERTICAL PANELS	(3)	(3)	(3)	(3)	(3)	(1,3)	YES
DIRECTION INDICATOR BARRICADE	NO	NO	NO	YES	NO	NO	NO
TYPE II BARRICADE	(3)	(3)	(3)	(3)	NO	NO	YES
PORTABLE TUBULAR MARKERS	NO	NO	YES	NO	YES	(1)	NO
FIXED TUBULAR MARKERS	(4)	(4)	(4)	(4)	(4)	YES	NO
FIXED VERTICAL PANELS	(4)	(4)	(4)	(4)	(4)	(4)	YES

- (1) Not allowed on freeways or expressways, or for durations of more than three days.
- (2) Place at normal spacing if sheeted with fluorescent orange prismatic sheeting. Place at 1/2 spacing in tapers but pay at the rate of one device per full space if orange stripes are Type III high performance sheeting. Intermixing of trim line channelizers with fluorescent orange and orange Type III high performance sheeting is not allowed.
- (3) Slashes must slope down toward direction traffic is to pass.
- (4) Fixed tubular markers or Vertical Panels may be substituted for any of the above situations with the approval of the Engineer.

TAPER FORMULAS:

$L = WS$ FOR SPEEDS OF 45 MPH OR MORE

$L = WS^2/60$ FOR SPEEDS OF 40 MPH OR LESS

WHERE: L = MINIMUM LENGTH OF TAPER IN FEET
 S = NUMERICAL VALUE OF POSTED SPEED PRIOR TO WORK STARTING IN MPH
 W = WIDTH OF OFFSET IN FEET

MKEC
 ENGINEERING CONSULTANTS
 411 N. WEBB ROAD
 WICHITA, KS. 67206
 316-684-9600

SENECA STREET
 PROJECT NAME

CHANNELIZING DEVICES
 SHEET TITLE

DESIGN BY: **GJR** DRAWN BY: **GJR** CHECKED BY: **GJA**

DATE: **OCTOBER 2001** JOB NO.: **98092** SHEET/OF: **70 / 87**