

ROCKWOOD & OAKWOOD
DISCONNECT #29

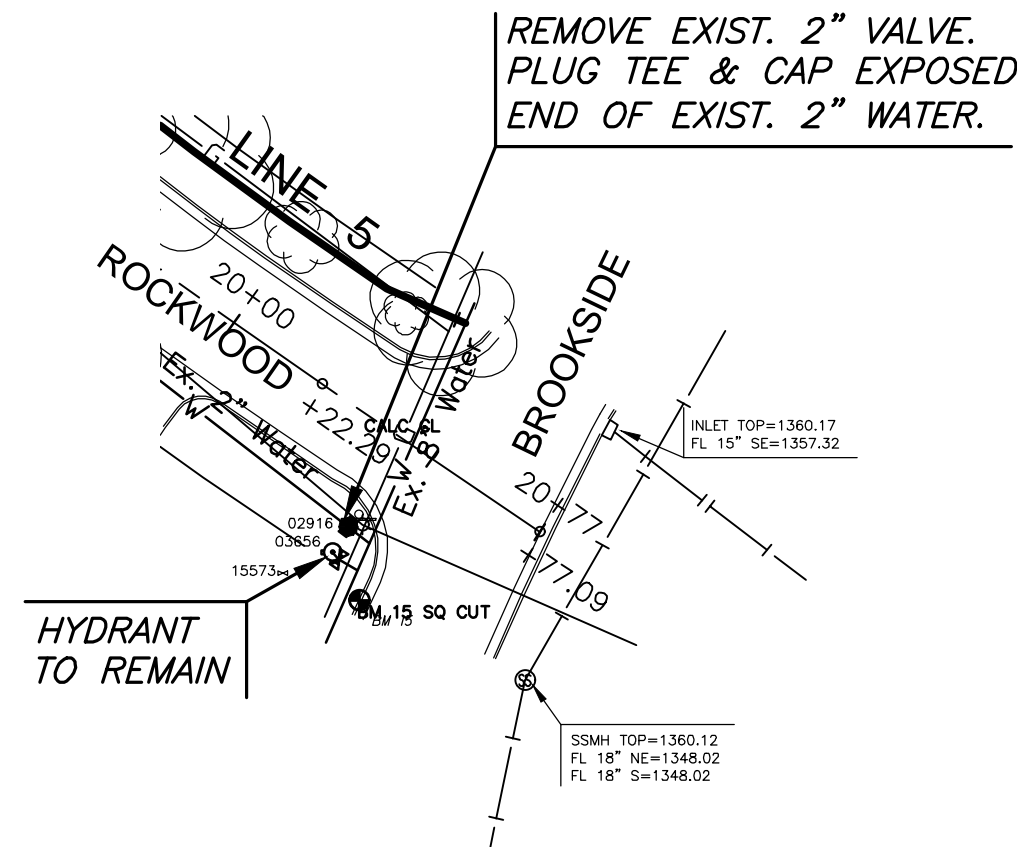

ROCKWOOD & BROOKSIDE
DISCONNECT #30

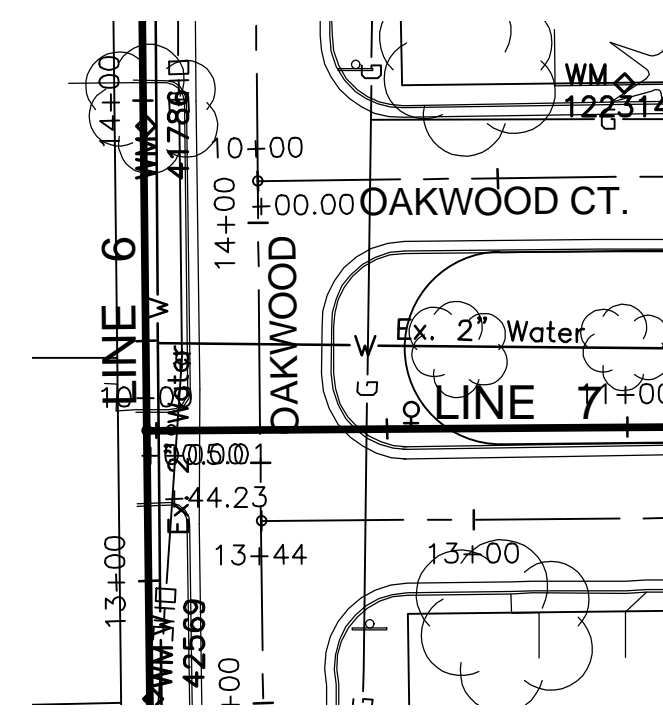

NO ACTION
OAKWOOD & OAKWOOD CT.
DISCONNECT #31

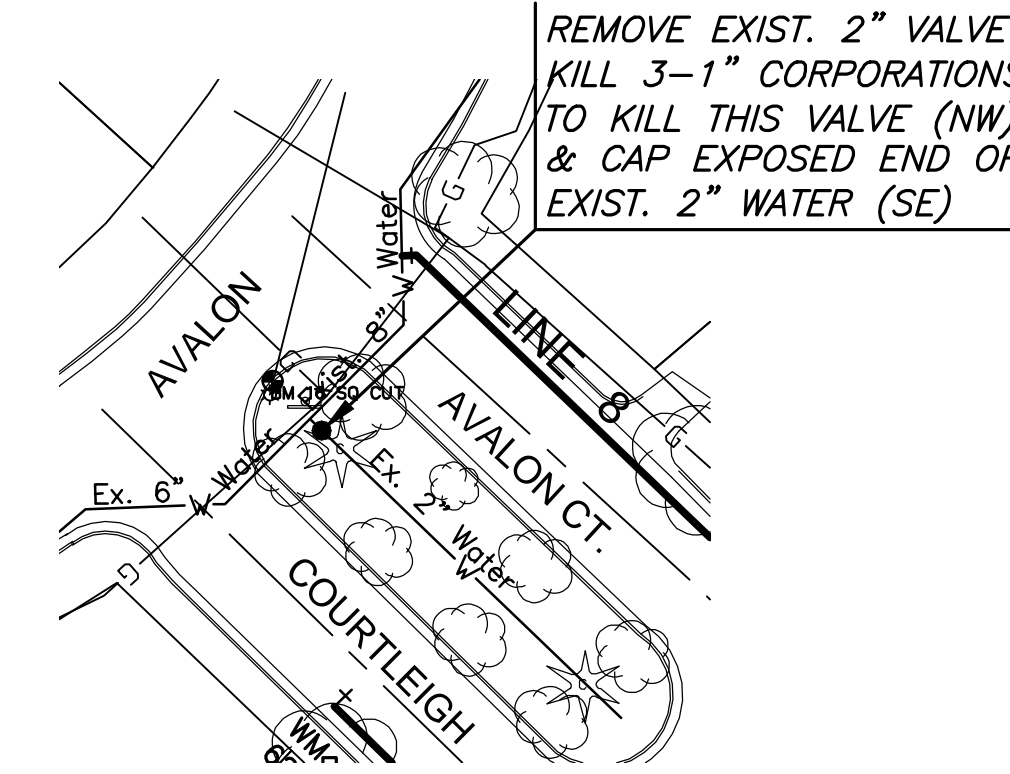

NO ACTION
AVALON & AVALON CT.
DISCONNECT #32

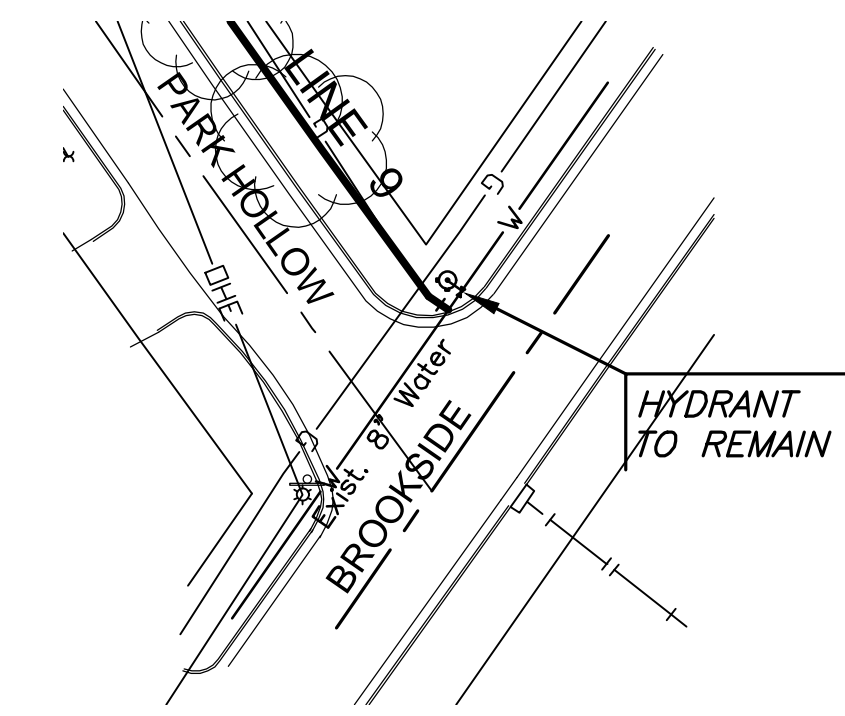

NO ACTION
PARK HOLLOW & BROOKSIDE
DISCONNECT #33

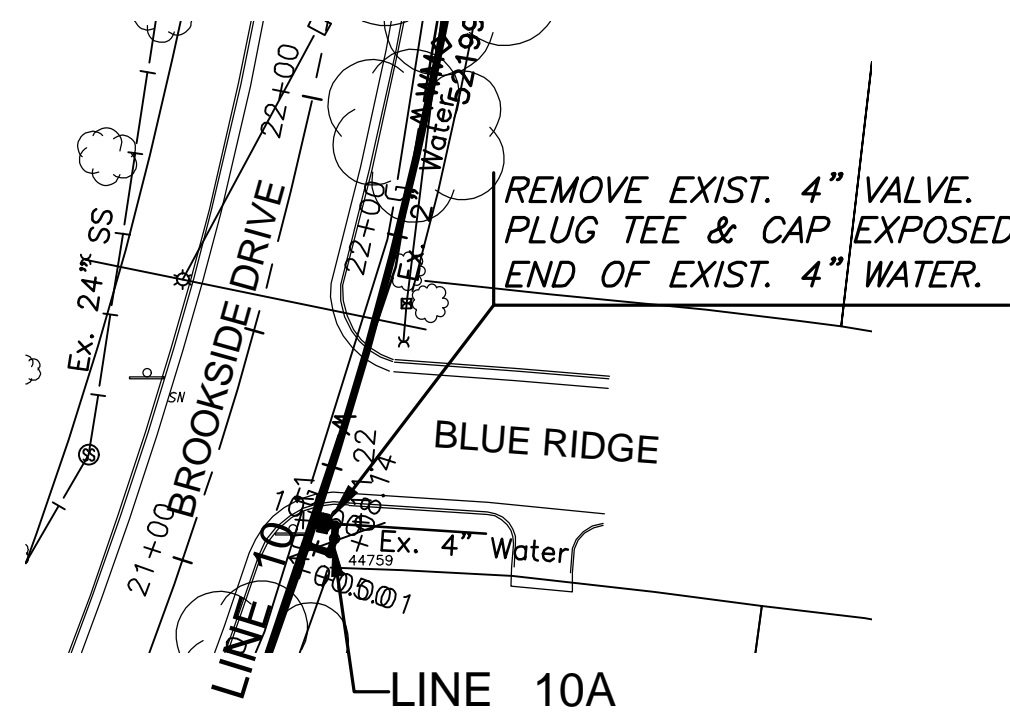

BROOKSIDE ST. & BLUERIDGE
DISCONNECT #34

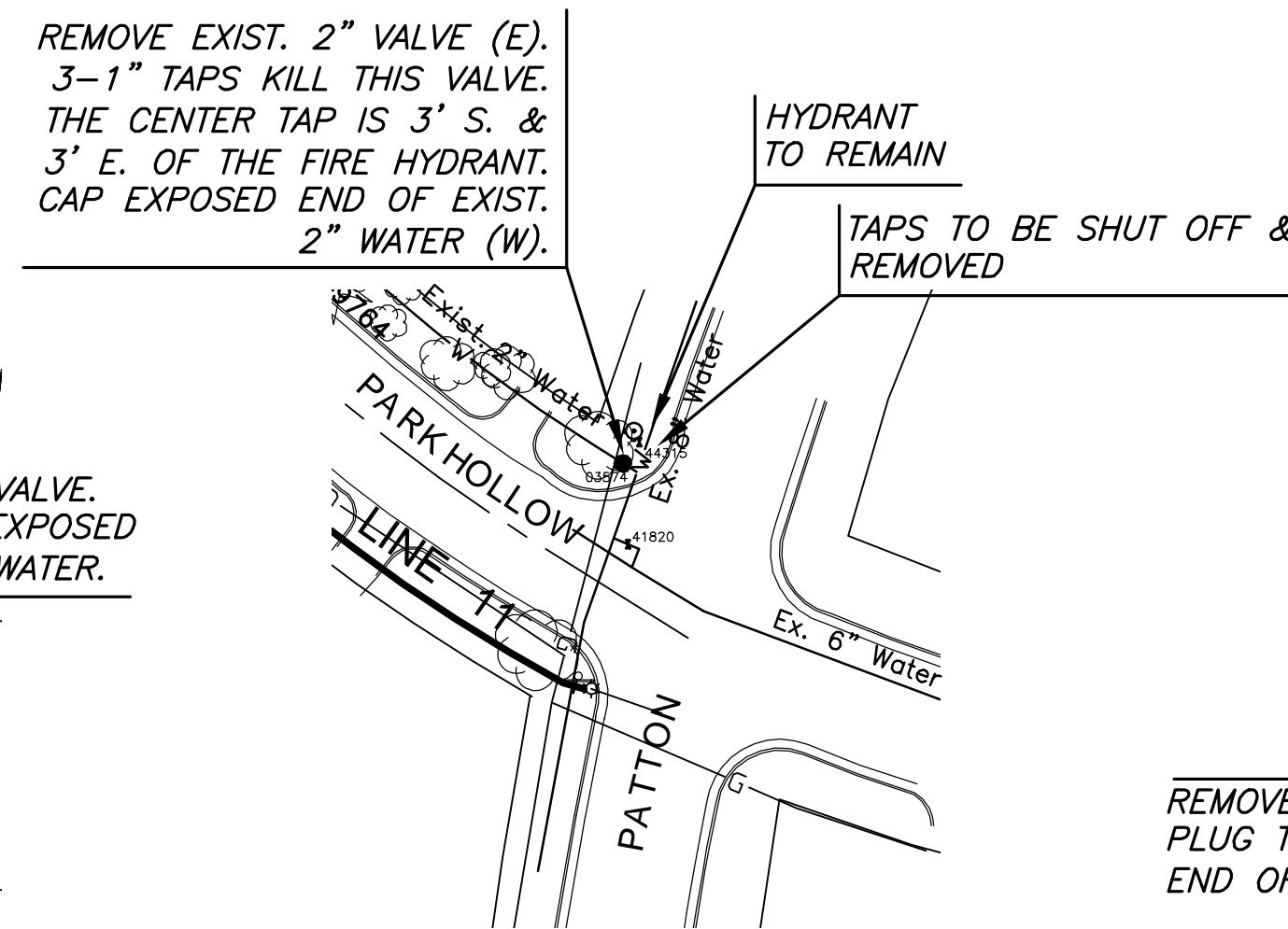

PARK HOLLOW & PATTON
DISCONNECT #35

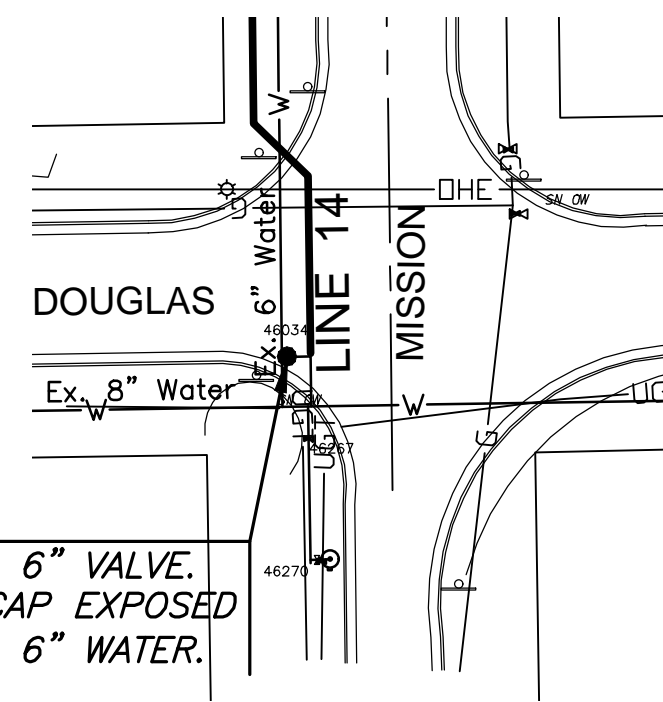

DOUGLAS & MISSION
DISCONNECT #36

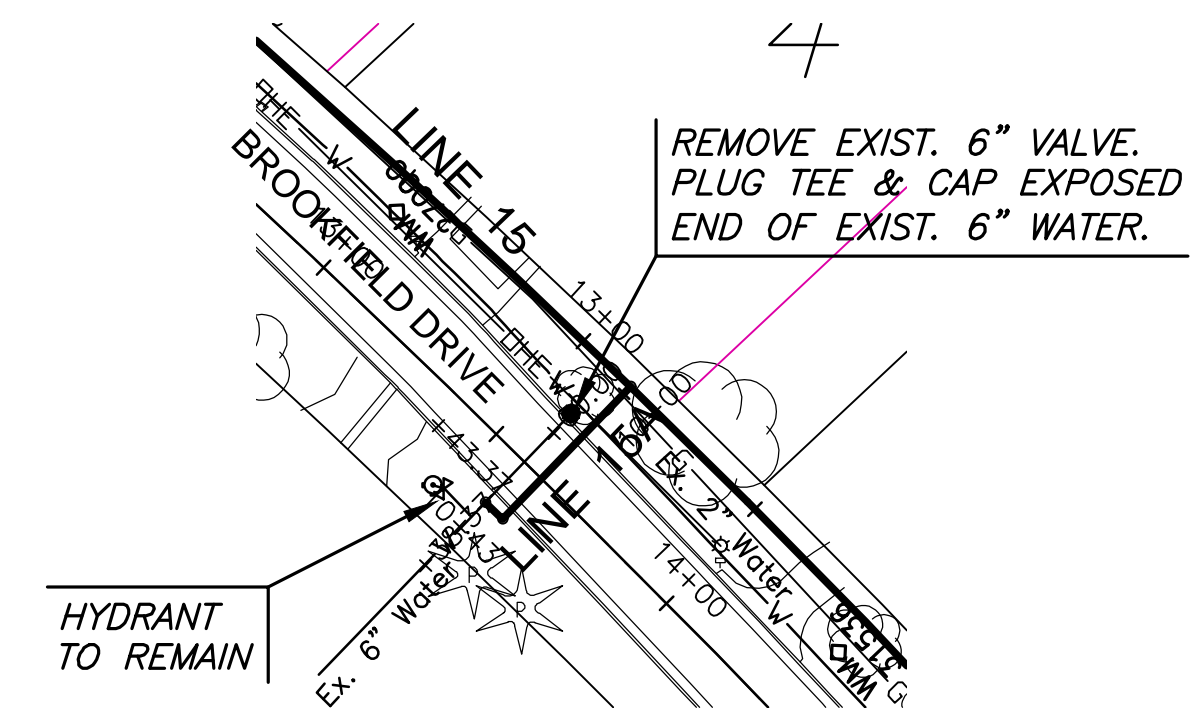

BROOKFIELD BETWEEN
NORFOLK & STRATFORD
DISCONNECT #37

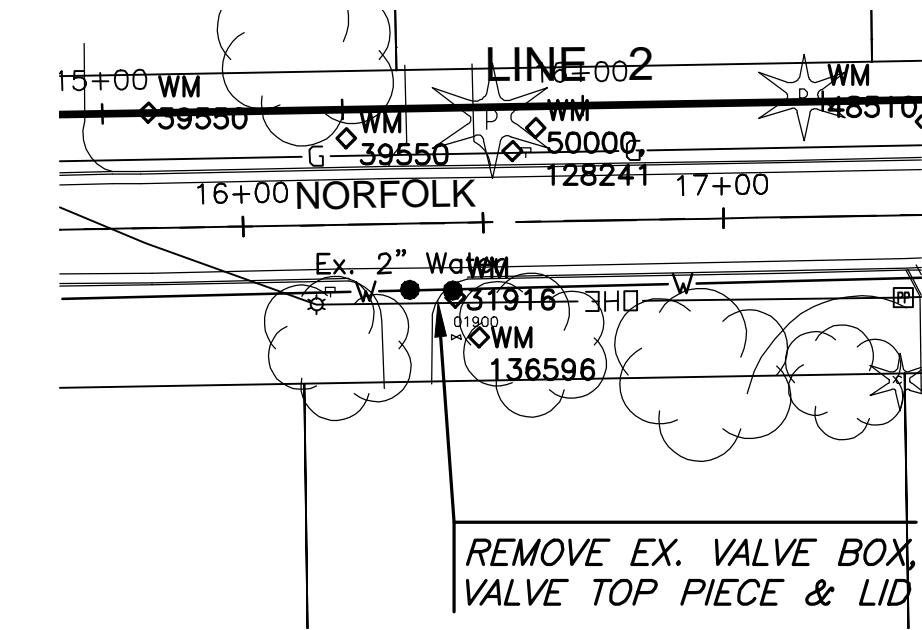

NORFOLK BETWEEN ST. JAMES
& HAMPTON
DISCONNECT #38

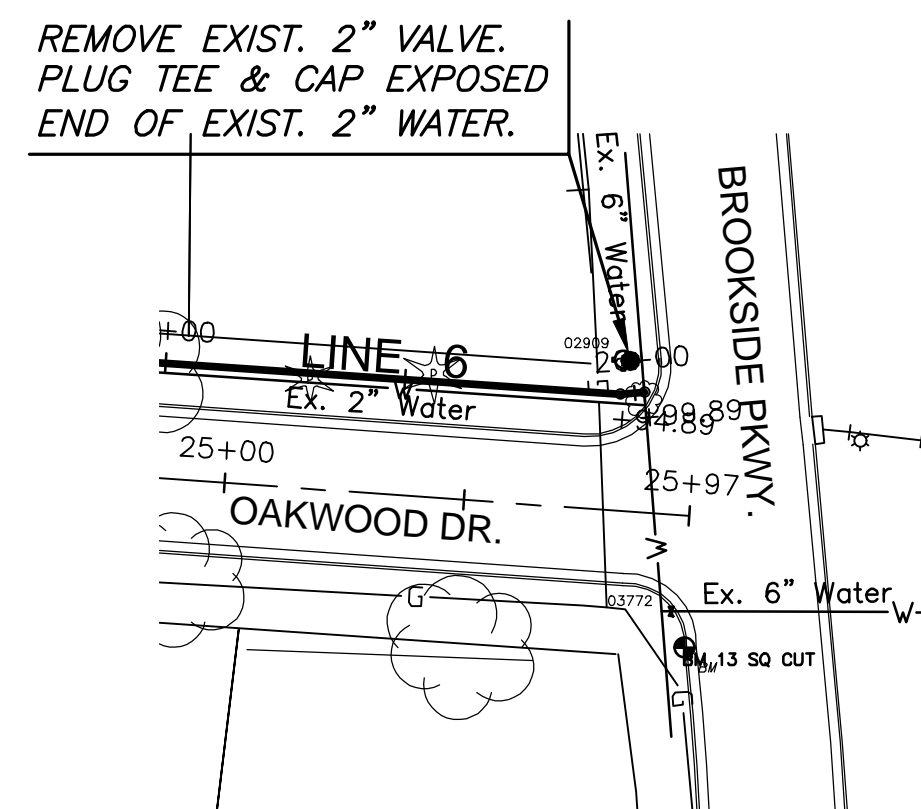

OAKWOOD DR. & BROOKSIDE PKWY.
DISCONNECT #39

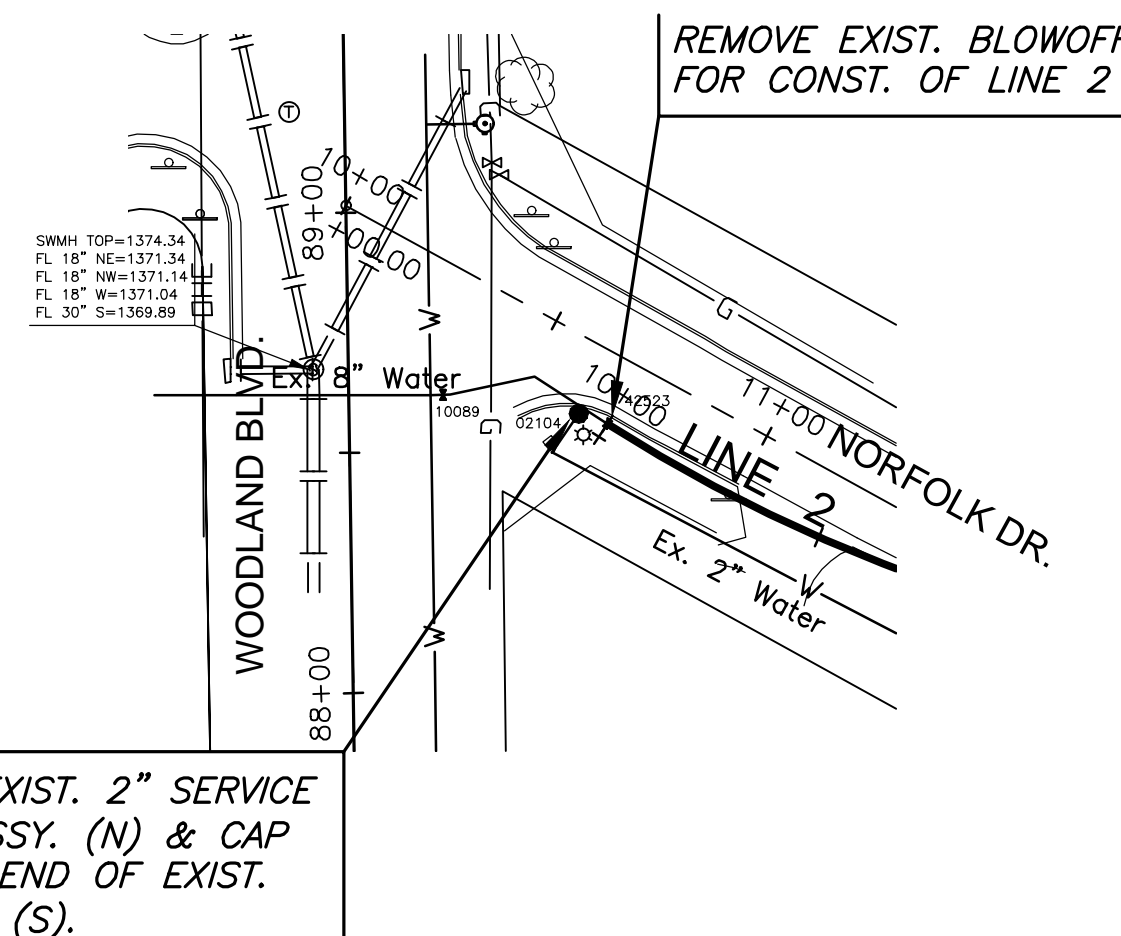

WOODLAND BLVD. & NORFOLK DR.
DISCONNECT #40

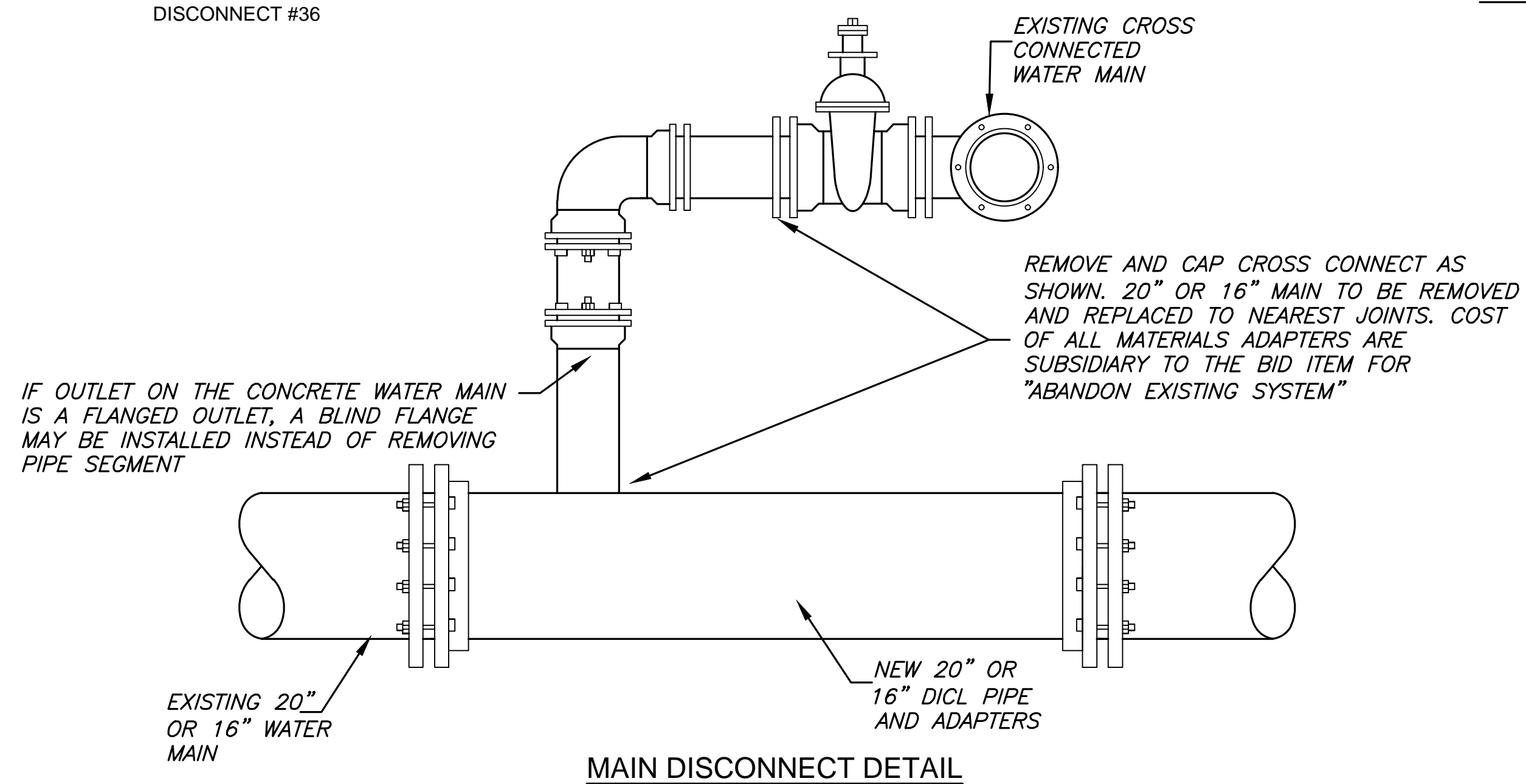

MAIN DISCONNECT DETAIL

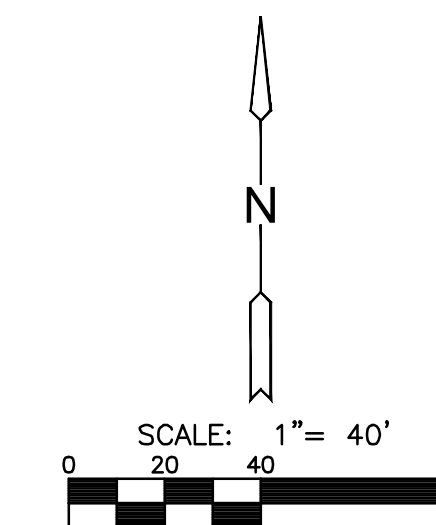

LEGEND

● = CUT & CAP EXIST. WATER LINE



©2013 MKEC Engineering All Rights Reserved
 These drawings and their contents, including, but not limited to, all concepts, designs, & ideas are the exclusive property of MKEC Engineering (MKEC), and may not be used or reproduced in any way without the express consent of MKEC.

DISCONNECT
DETAILS 29-36

PROJECT NO.	448-90610	
DATE	SEPT. 2017	
SCALE	AS SHOWN	
DESIGNED	DRAWN	CHECKED
JTC	DM	JRA

NO.	REVISION	DATE
-----	----------	------

SHEET NO.