

CURTIS CY Excavation (unadjusted)				CURTIS CY Loose Fill (unadjusted)			
Station	Area	Volume	Total	Station	Area	Volume	Total
0+37	15.45	0.00	0.00	0+37	11.13	0.00	0.00
0+50	15.46	7.44	7.44	0+50	11.13	5.36	5.36
1+00	15.46	28.63	36.07	1+00	11.13	20.60	25.96
1+50	15.46	28.63	64.70	1+50	11.13	20.60	46.56
2+00	15.46	28.63	93.33	2+00	11.13	20.56	67.12
2+50	15.46	28.63	121.96	2+50	11.13	20.51	87.63
3+00	15.46	28.63	150.59	3+00	11.13	20.51	108.14
3+19.51	15.46	11.17	161.76	3+19.51	12.71	8.62	116.77
3+68.15	23.78	36.02	197.78	3+68.15	5.82	16.38	133.14
4+24.20	15.21	40.47	238.24	4+24.20	12.22	18.73	151.87
4+50	15.46	14.65	252.90	4+50	10.75	10.98	162.85
5+00	15.46	28.63	281.53	5+00	10.69	19.85	182.70
5+50	15.46	28.63	310.16	5+50	11.07	20.15	202.85
6+00	15.46	28.63	338.79	6+00	10.75	20.16	223.01
6+50	15.46	28.63	367.41	6+50	9.20	19.03	242.04
7+00	15.46	28.63	396.04	7+00	7.22	16.60	258.63
7+50	15.46	28.63	424.67	7+50	7.64	13.75	272.39
8+00	15.46	28.63	453.30	8+00	9.82	16.16	288.55
8+50	15.46	28.63	481.93	8+50	7.06	15.63	304.17
9+00	15.46	28.63	510.56	9+00	7.31	13.31	317.48
9+50	15.46	28.63	539.19	9+50	7.95	14.13	331.62
10+00	15.46	28.63	567.82	10+00	7.34	14.16	345.78
10+50	15.46	28.63	596.45	10+50	7.18	13.45	359.22
10+65.52	15.46	8.88	605.33	10+65.52	12.71	5.72	364.94
10+99.60	22.31	23.84	629.17	10+99.60	5.82	11.70	376.64
11+47.81	15.46	32.61	661.79	11+47.81	11.13	16.03	392.66

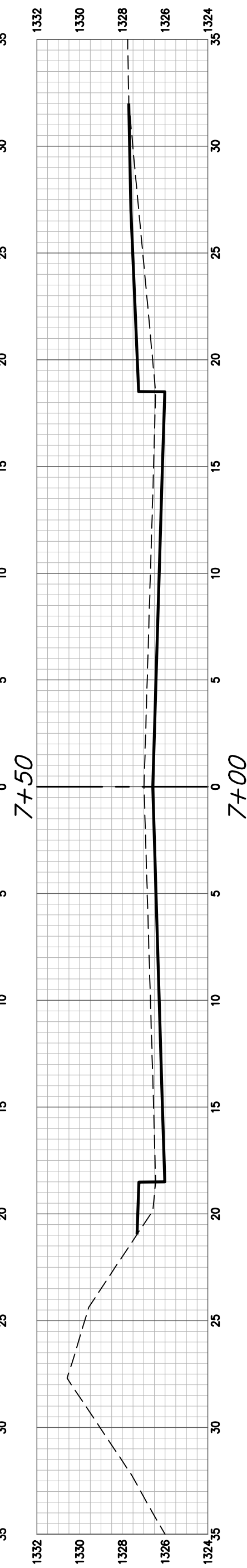

CURTIS

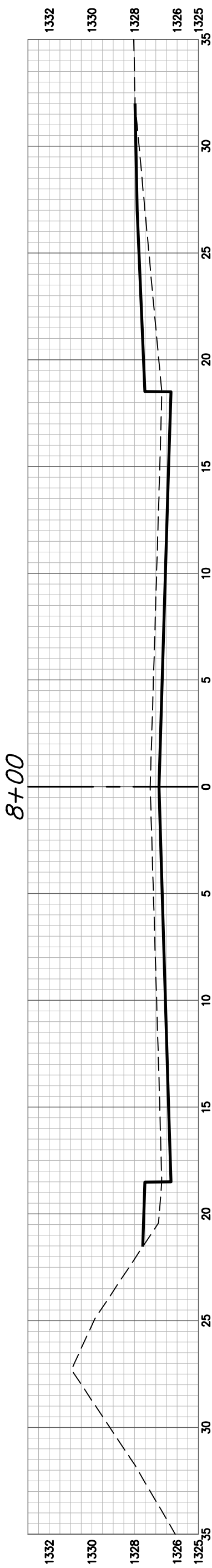
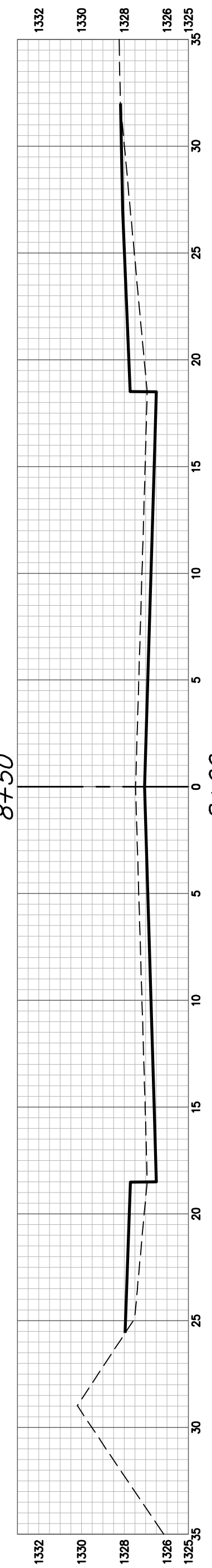
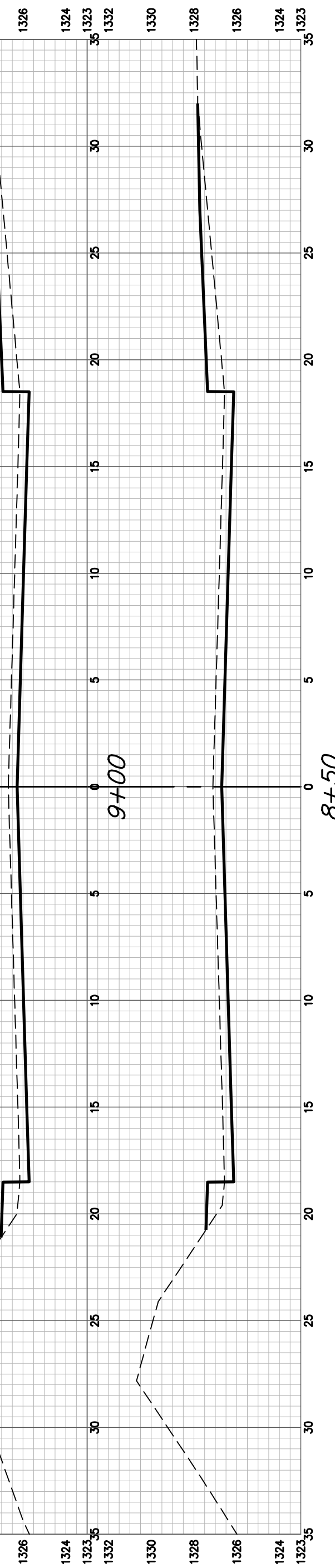
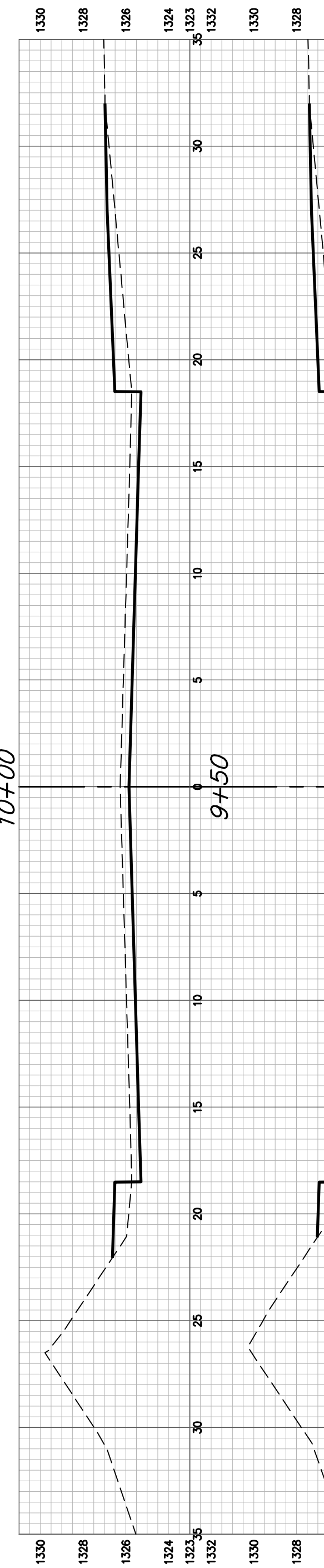
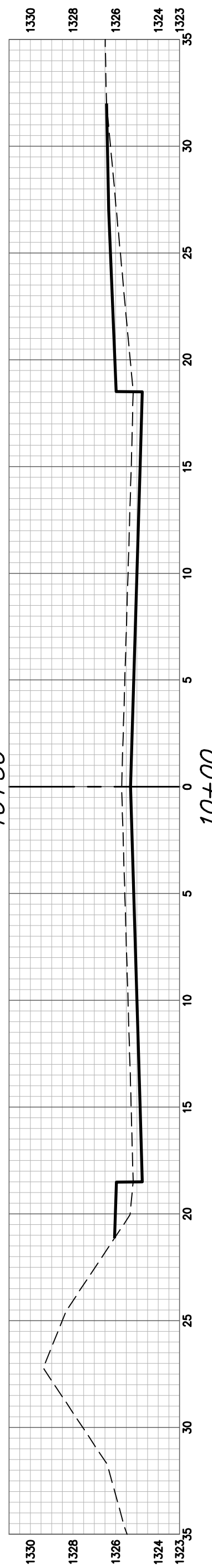
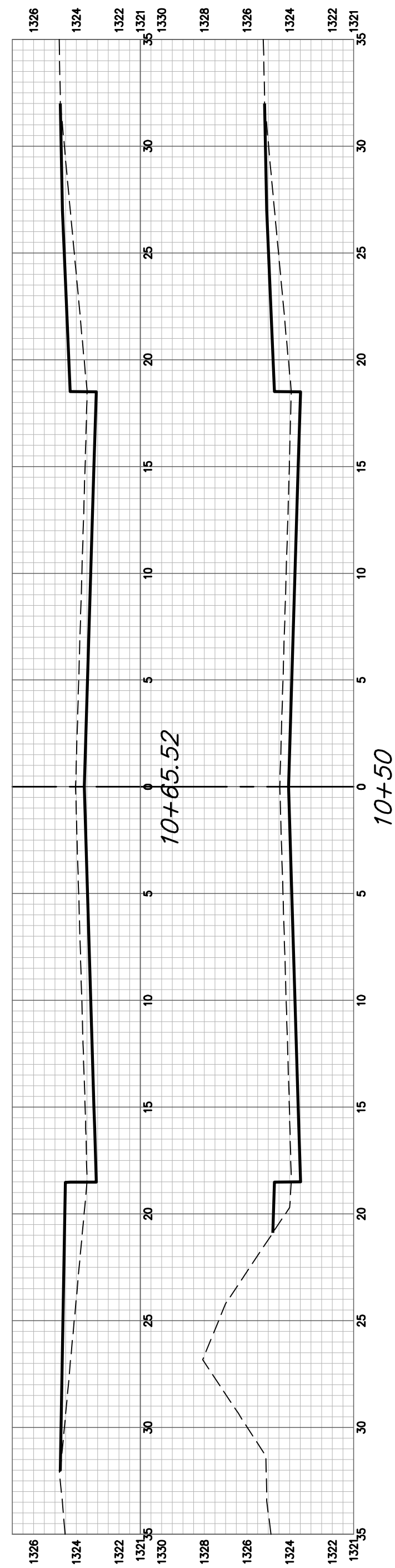
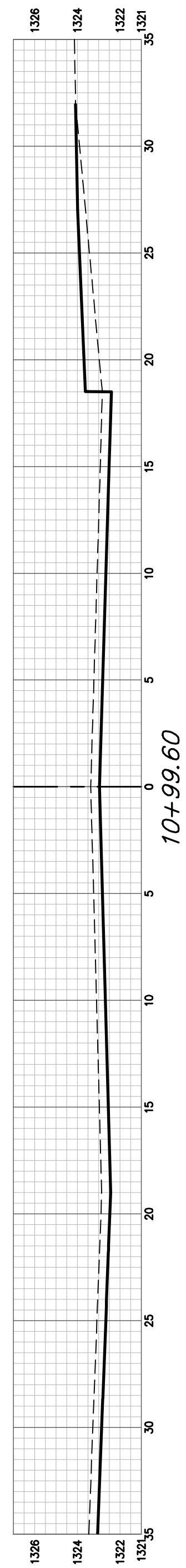
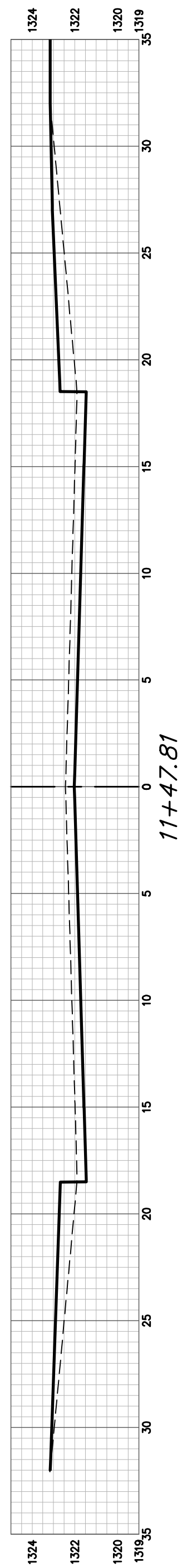