

**29TH STREET**  
**STA. 15+00.00 to 29+00.00**  
 1" = 50'

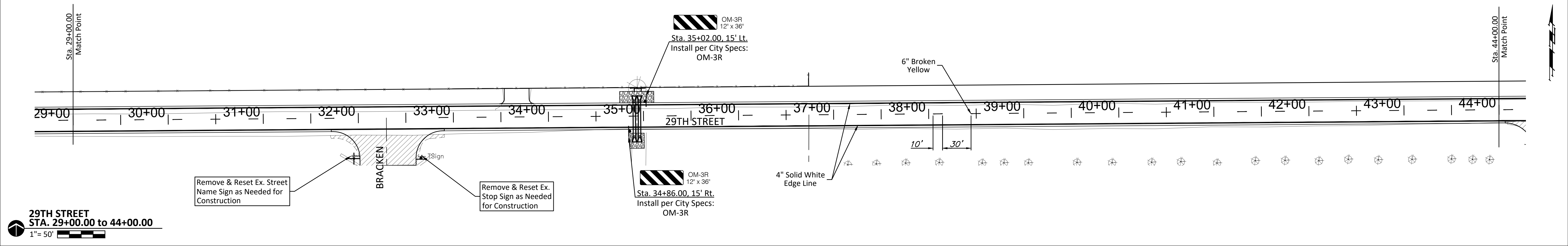

**29TH STREET**  
**STA. 29+00.00 to 44+00.00**  
 1" = 50'

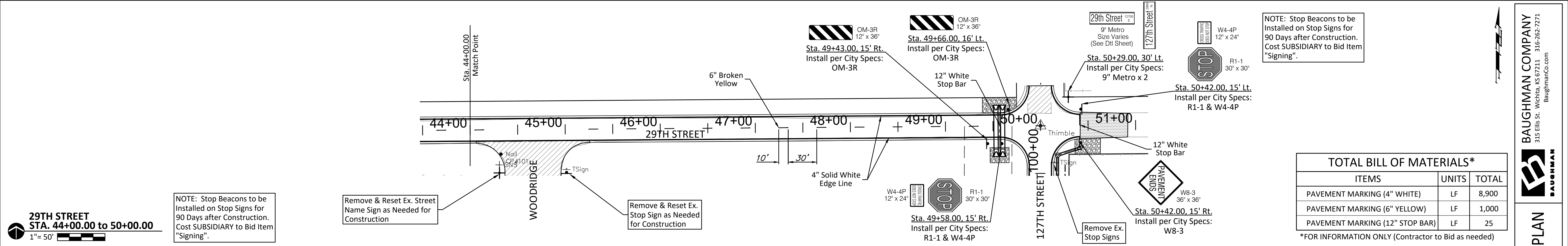

**29TH STREET**  
**STA. 44+00.00 to 50+00.00**  
 1" = 50'

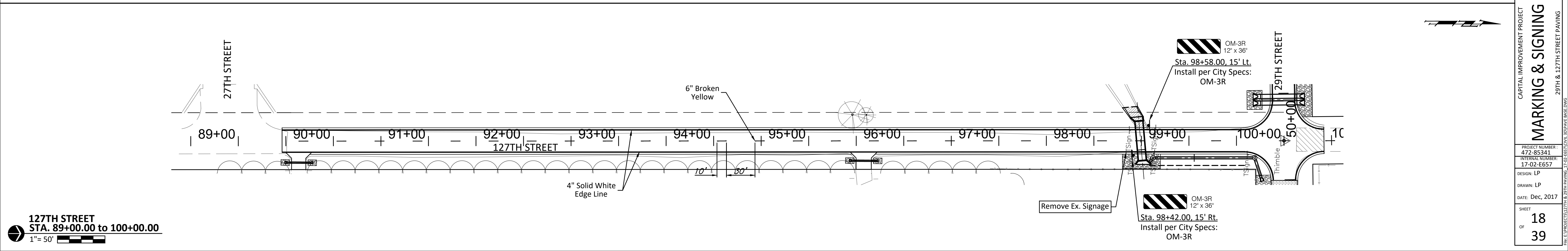

**127TH STREET**  
**STA. 89+00.00 to 100+00.00**  
 1" = 50'

**BAUGHMAN COMPANY**  
 315 Ellis St. Wichita, KS 67211 316-262-7271  
 baughmanco.com

**MARKING & SIGNING PLAN**

CAPITAL IMPROVEMENT PROJECT  
 29TH & 127TH STREET PAVING  
 THE PAVEMENTS, 127TH & 29TH PAVING, 17-02-E657-DWG, 30" PAVE BASE DWS

PROJECT NUMBER: 472-85344  
 INTERNAL NUMBER: 17-02-E657  
 DESIGN: LP  
 DRAWN: LP  
 DATE: Dec, 2017  
 SHEET  
 OF 18  
 39