

FHWA REG NO.	Sta. TE	PROJECT NO.	YEAR	SHEET NO.	TOTAL SHEETS
	KANSAS	87 N-0199-01	2002	13	158

FED. AID NO. - CMQ-NO19(901)

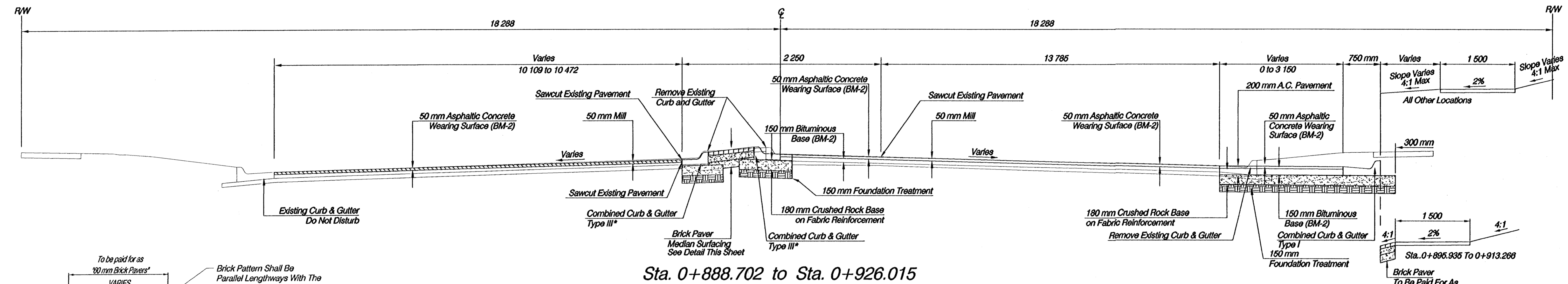

Sta. 0+888.702 to Sta. 0+926.015

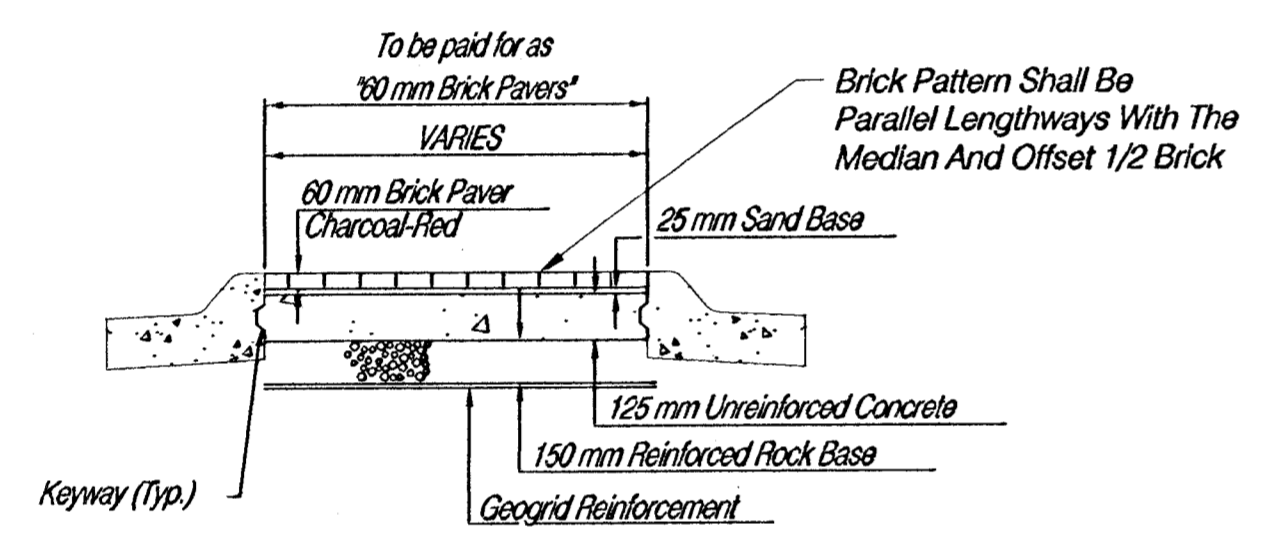

BRICK PAVER SURFACE DETAIL

\* Width Varies For Modified Curbs & Gutter Sections.  
See Sheet 96 For Modified Curb & Gutter Locations.  
See Sheet 96 For Modified Curb & Gutter Detail.  
A 150 mm P.C.C. Base Shall Be Used In Place Of 150 mm  
BM-2 Base Course Where Proposed Paving Is Less  
Than 1.5 m In Width. (Typ)  
Sod All Disturbed Areas.

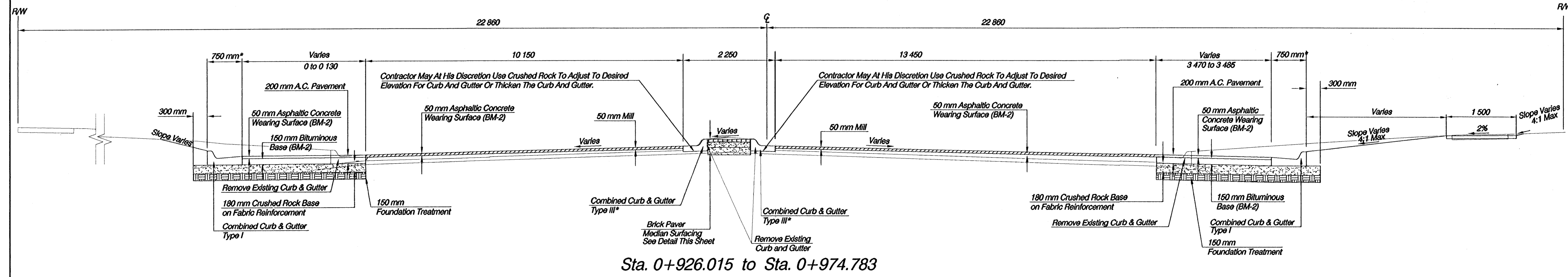

Sta. 0+926.015 to Sta. 0+974.783

**ROCK ROAD**  
TYPICAL SECTIONS

**HWS** Consulting Group Inc. Omaha Office  
10844 Old Mill Rd., Ste 1  
Omaha, NE 68154  
Phone: (402) 333-5792  
Fax: (402) 333-2248

Designed By: BWE	Checked By: RJK
Drawn By: HS	Date: 03-25-2002 Job No. 55-70-2003