

BENCHMARKS:

BM #1: "□" Top of Curb NE of the most easterly corner of Lot 2B, Block E, Falcon Falls 2nd Addition
Elev. = 1361.23 (NGVD29)

BM #2: "□" Top of Curb North of the NE corner of Lot 2, Block D, Falcon Falls 3rd Addition
Elev. = 1351.76 (NGVD29)

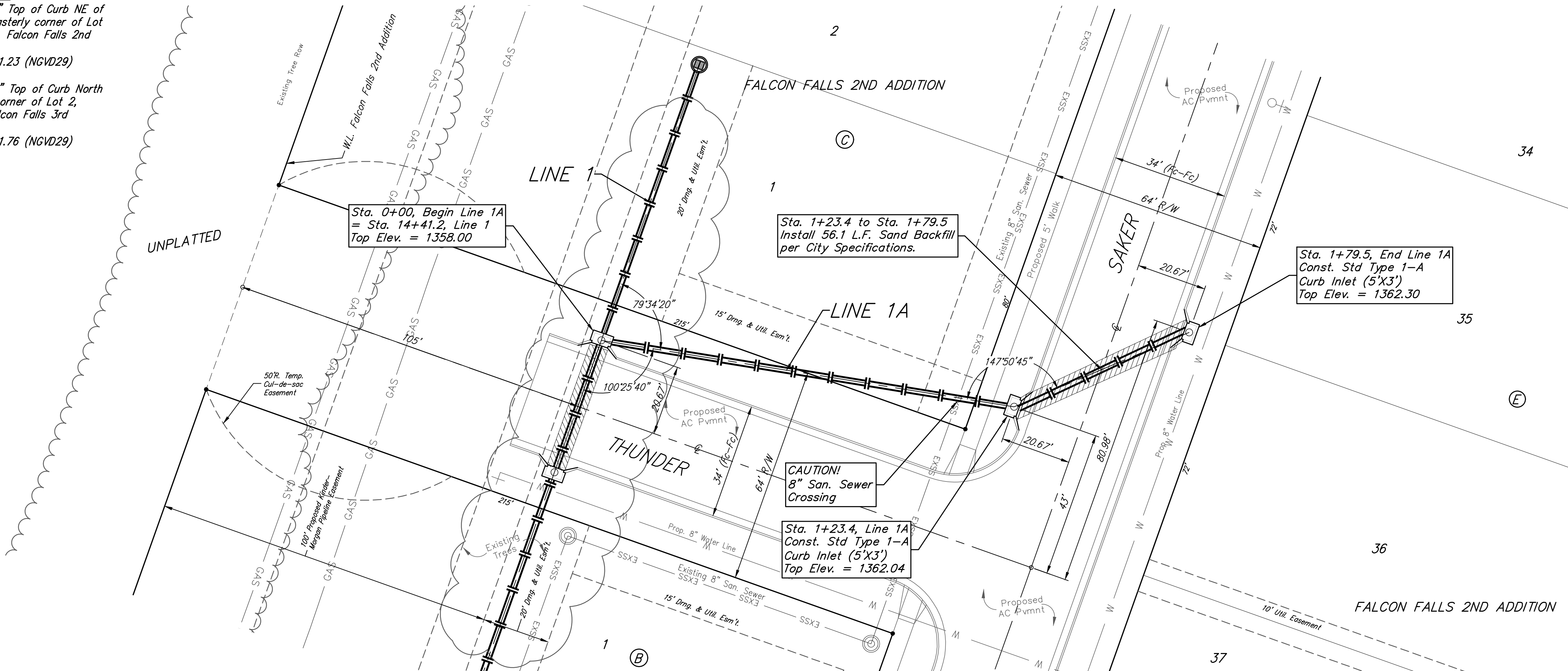
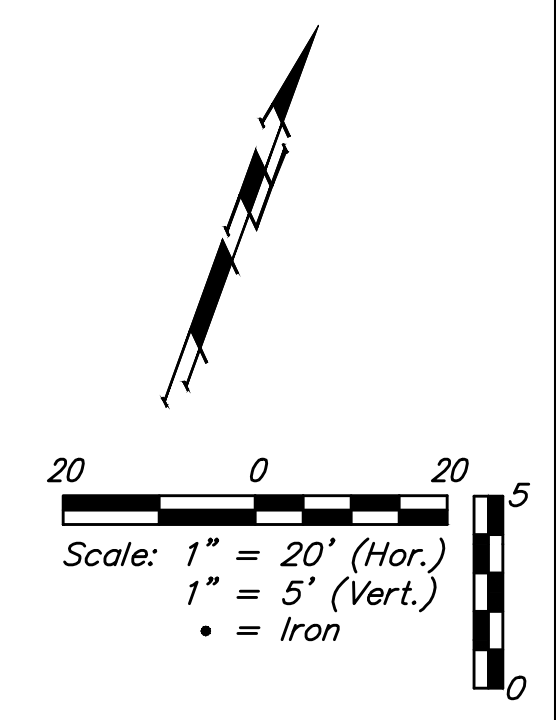

Existing trees which are in direct conflict with proposed new construction shall be removed or chainsaw trimmed by the Contractor ONLY with Developer's approval. Trees not in direct conflict with proposed new construction shall remain and be protected from damage. Cost to be included in bid item, "Site Clearing".

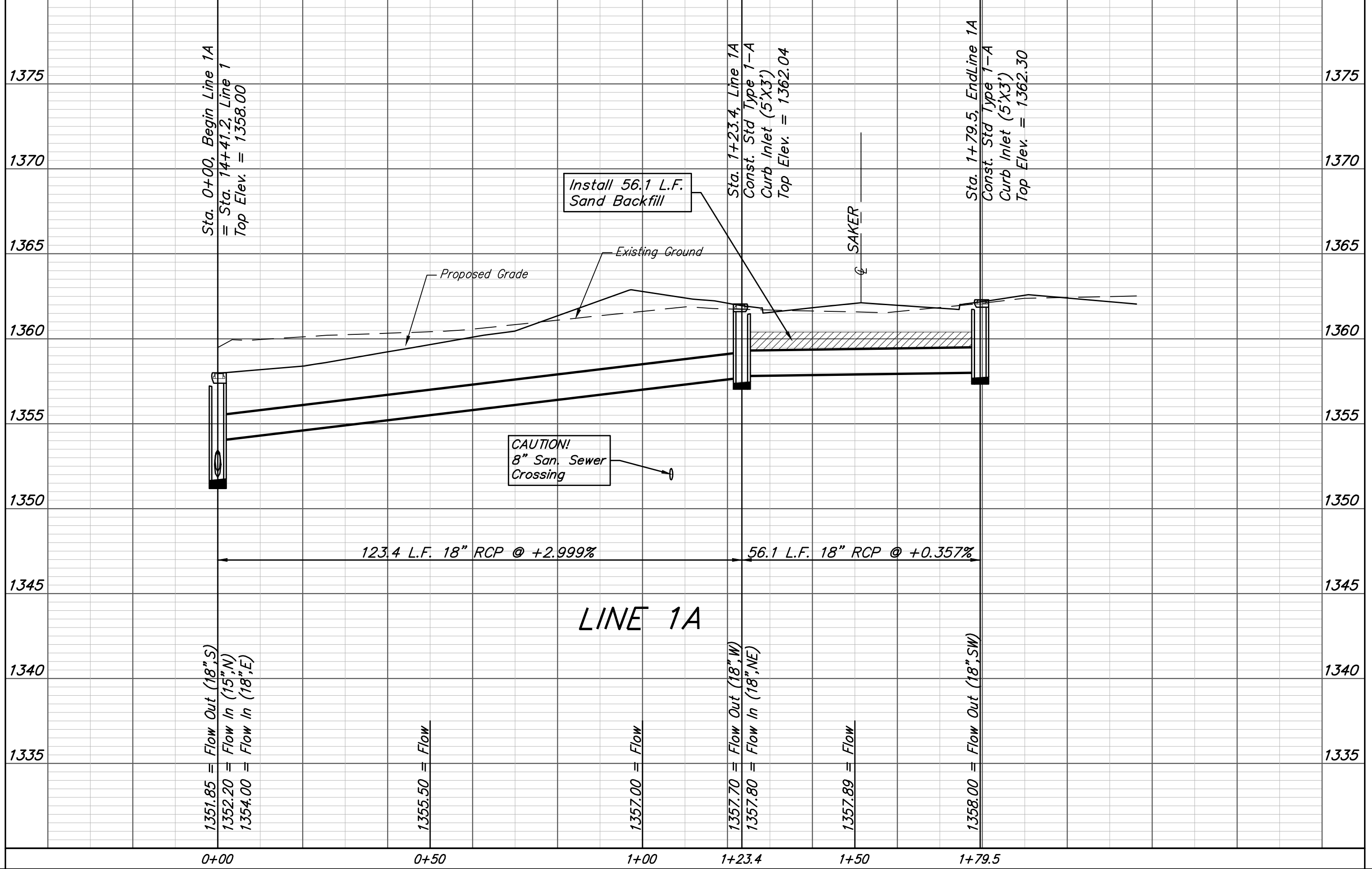

		Falcon Falls 2nd Addition - Phase 4A	
		LINE 1A	
Storm Water Sewer Improvements #731		Baughman Company, P.A. 315 Ellis St. Wichita, KS 67211 P 316-262-7271 F 316-262-0149 ENGINEERING SURVEYING PLANNING LANDSCAPE ARCHITECTURE	
PROJECT NUMBER 468-85340	DESIGN AEG	DRAWN JAK	APPROVED DATE 9/04/18
REVISIONS:	SCALE Noted SHEET		
			6 OF 24