

EXPANSION JOINT

NOTE: Extra Thickness to be Subsidiary to Price of Square Yards Pavement

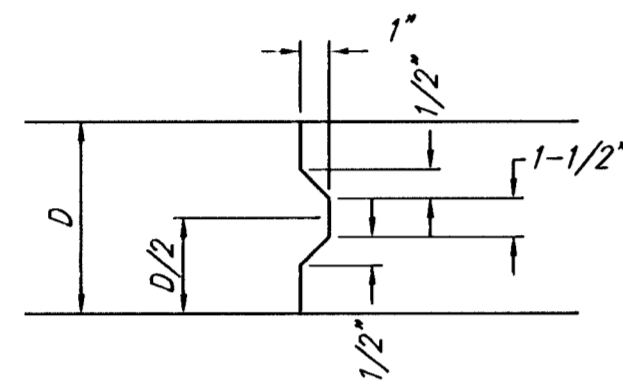

KEYWAY DETAIL

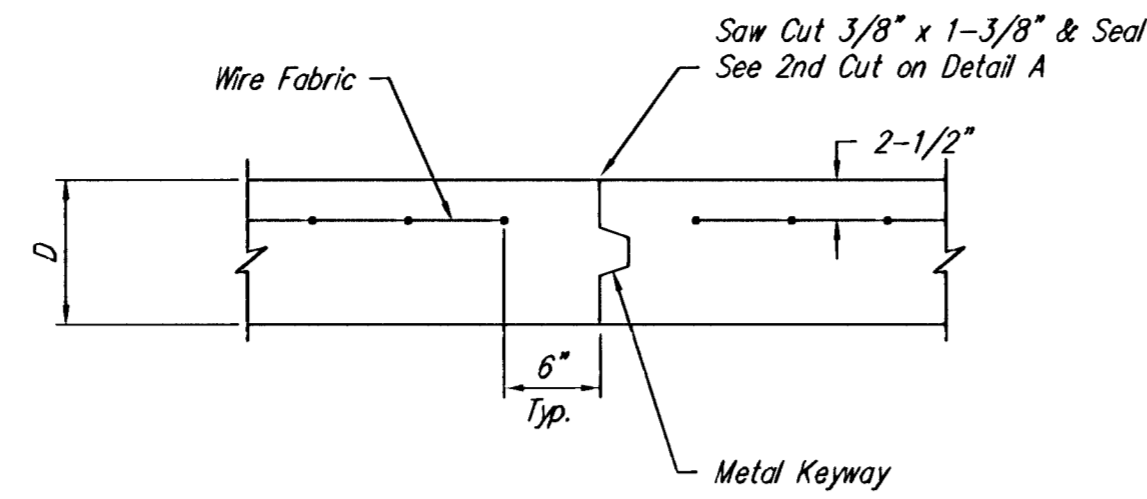

OPTIONAL CONTRACTION JOINT

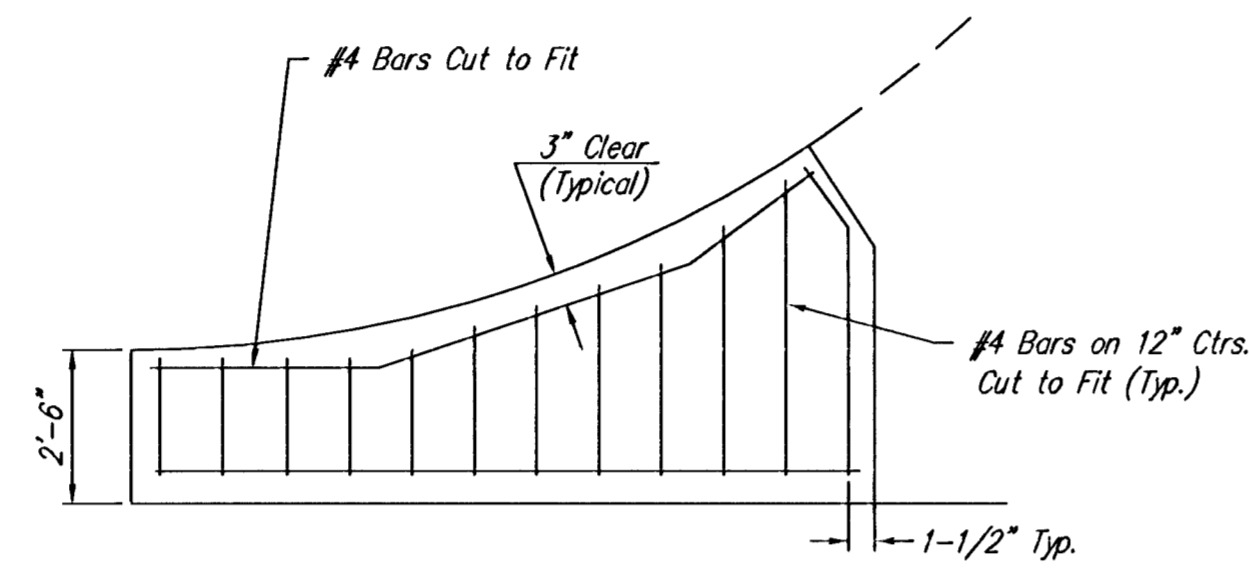

WING REINFORCING DETAIL

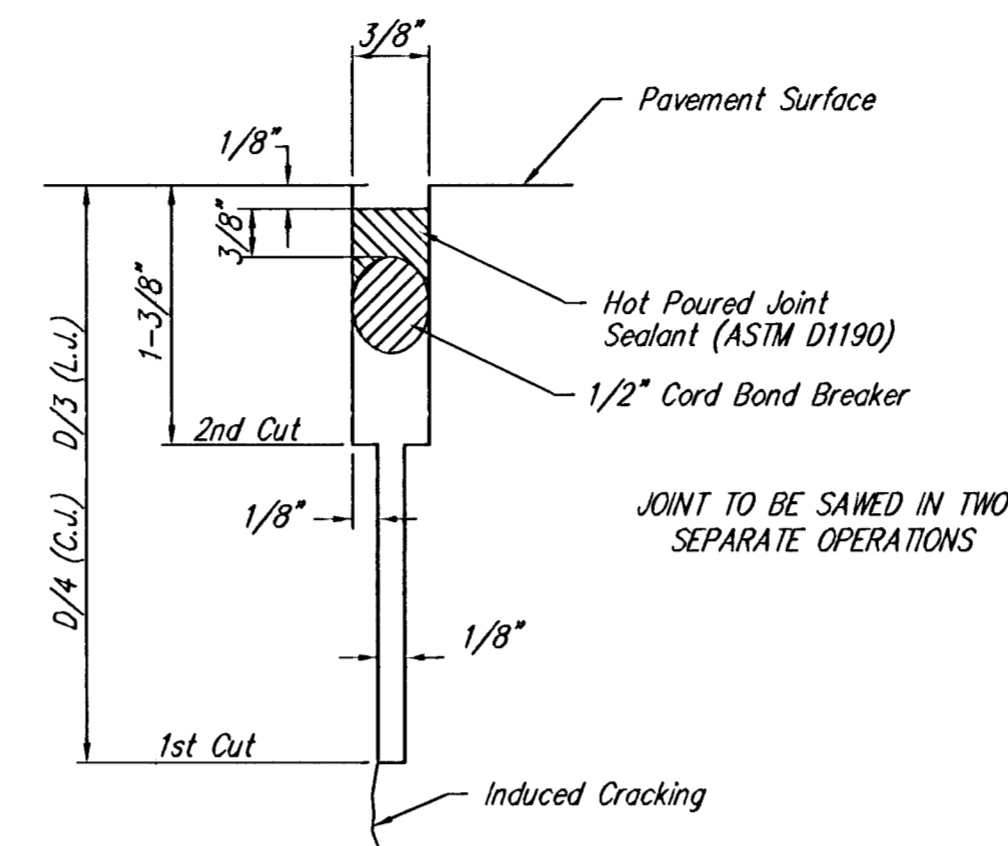

SAW JOINT DETAIL

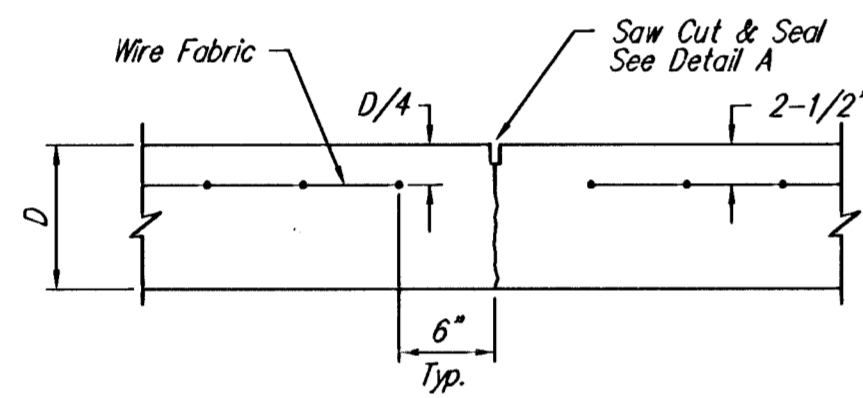

CONTRACTION JOINT DETAIL (C.J.)

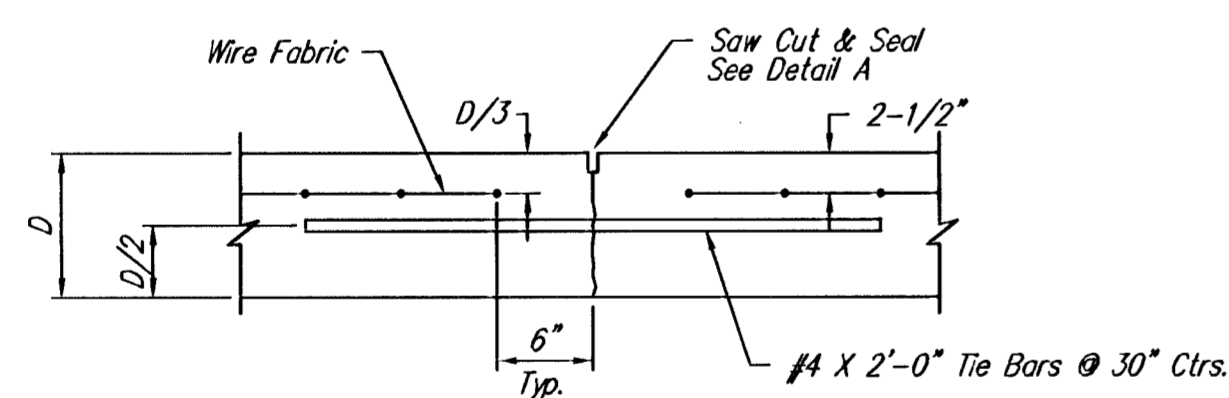

LONGITUDINAL JOINT DETAIL (L.J.)

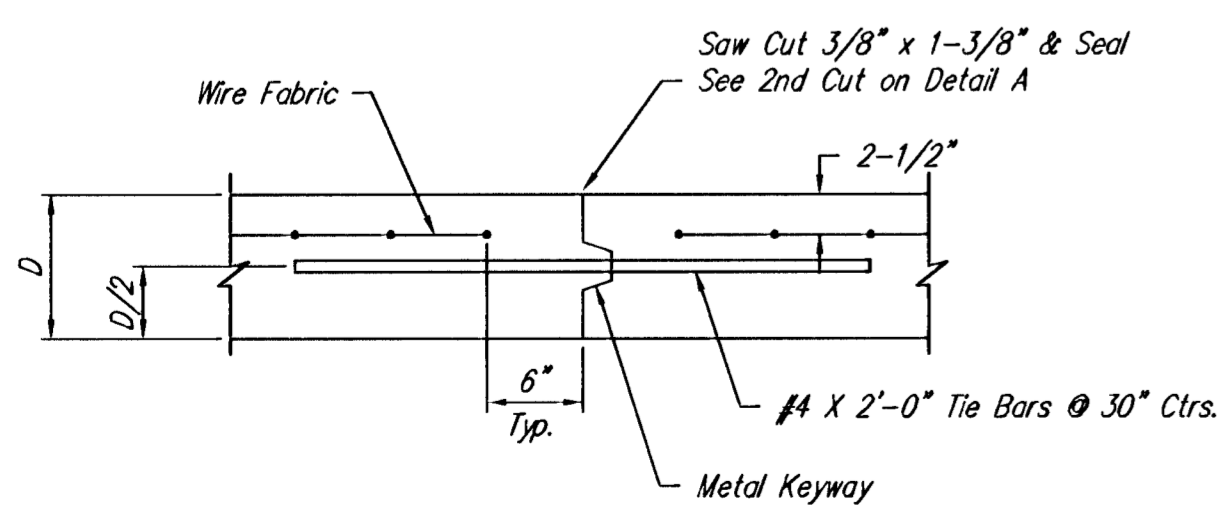

OPTIONAL LONGITUDINAL JOINT DETAIL (L.J.)

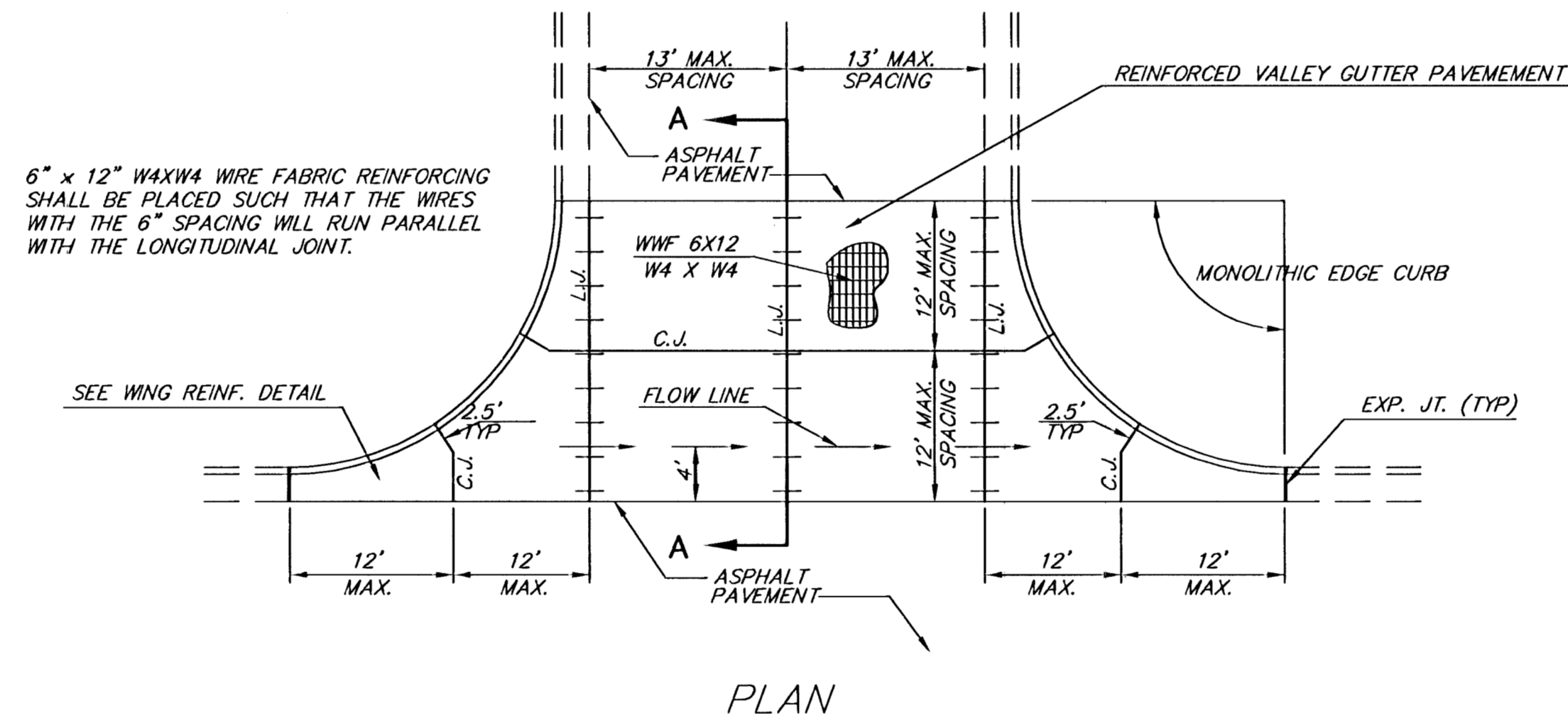

PLAN

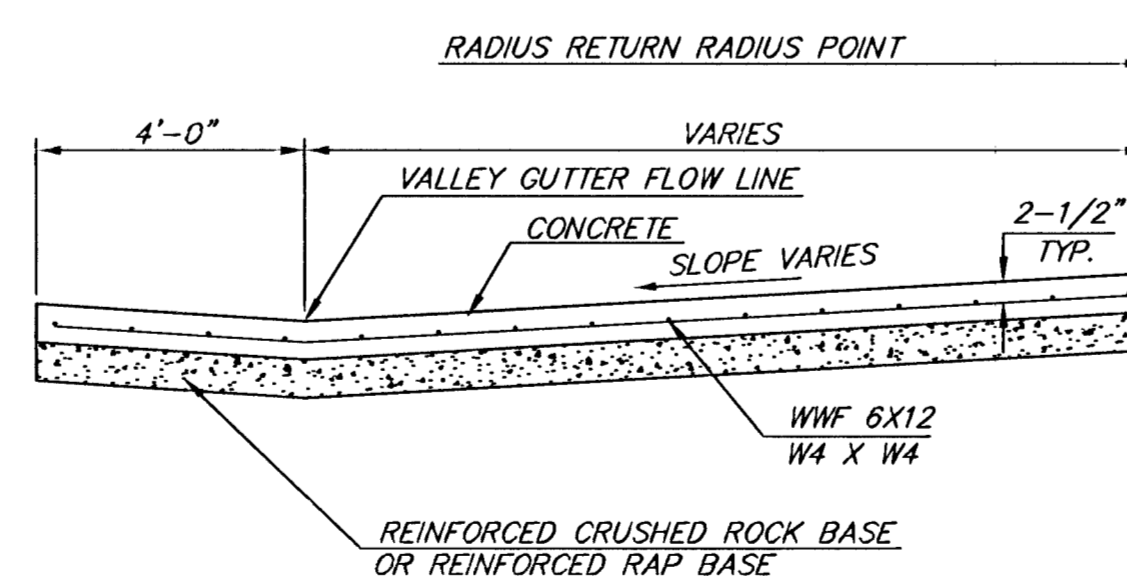

SECTION A-A

REINFORCED VALLEY GUTTER DETAIL

THE CITY OF WICHITA

CITY ENGINEER'S OFFICE
CITY HALL - SEVENTH FLOOR
405 NORTH MAIN STREET
WICHITA, KANSAS 67202
(316) 268-4501
(316) 268-4114 FAX

VALLEY GUTTER DETAILS
WHEELCHAIR RAMP
DETAILS

NEIL D. CABLE, P.E. - CITY ENGINEER

PROJECT NUMBER XXX-XXXX	INDEX CODE XXXXXX
DATE APR 03	SHEET 4 OF 23