

**EXPANSION JOINT**

NOTE: Extra Thickness to be Subsidiary to Price of Square Yards Pavement

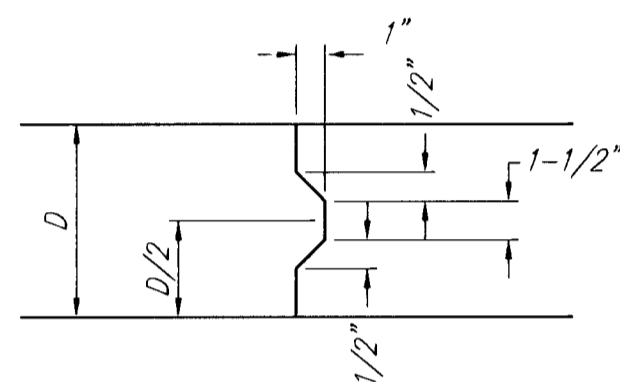

**KEYWAY DETAIL**

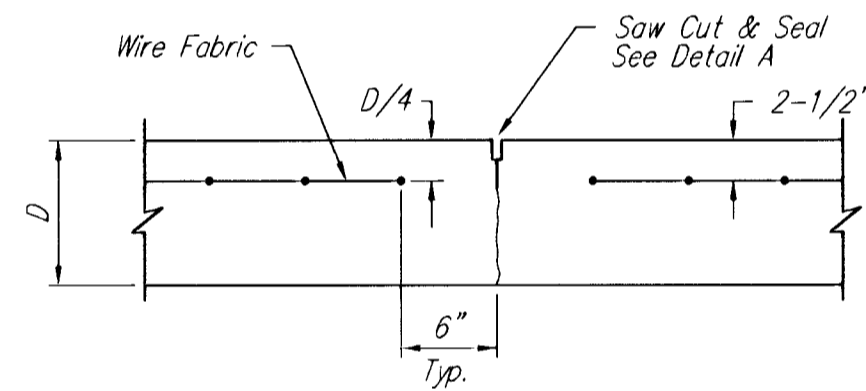

**CONTRACTION JOINT DETAIL (C.J.)**

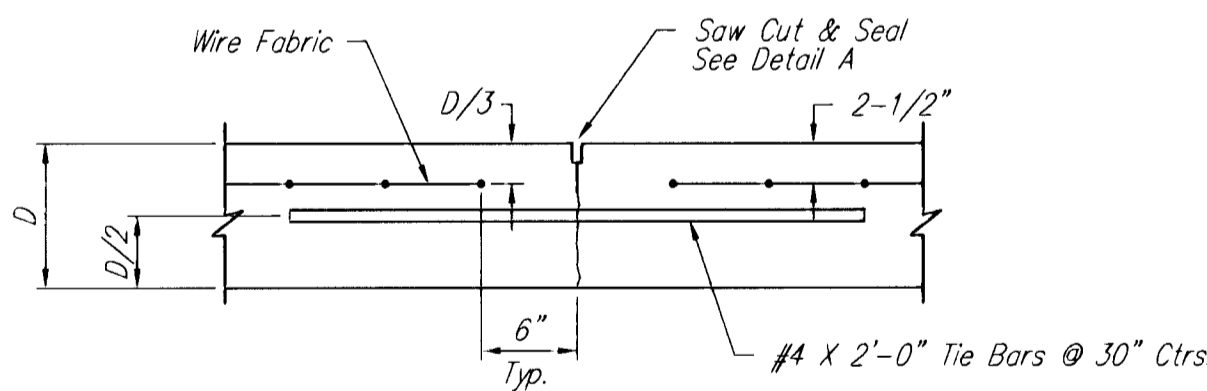

**LONGITUDINAL JOINT DETAIL (L.J.)**

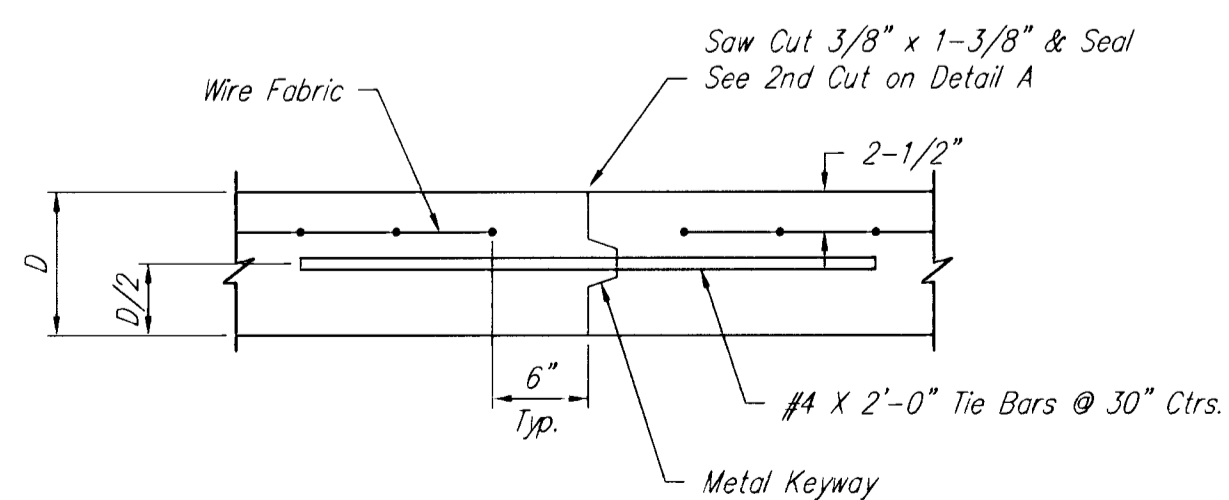

**OPTIONAL LONGITUDINAL JOINT DETAIL (L.J.)**

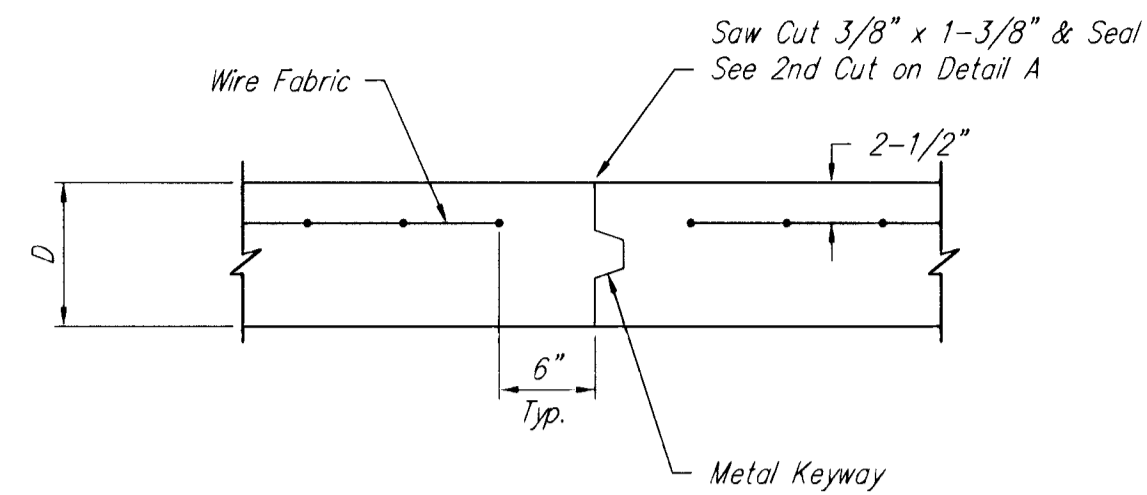

**OPTIONAL CONTRACTION JOINT**

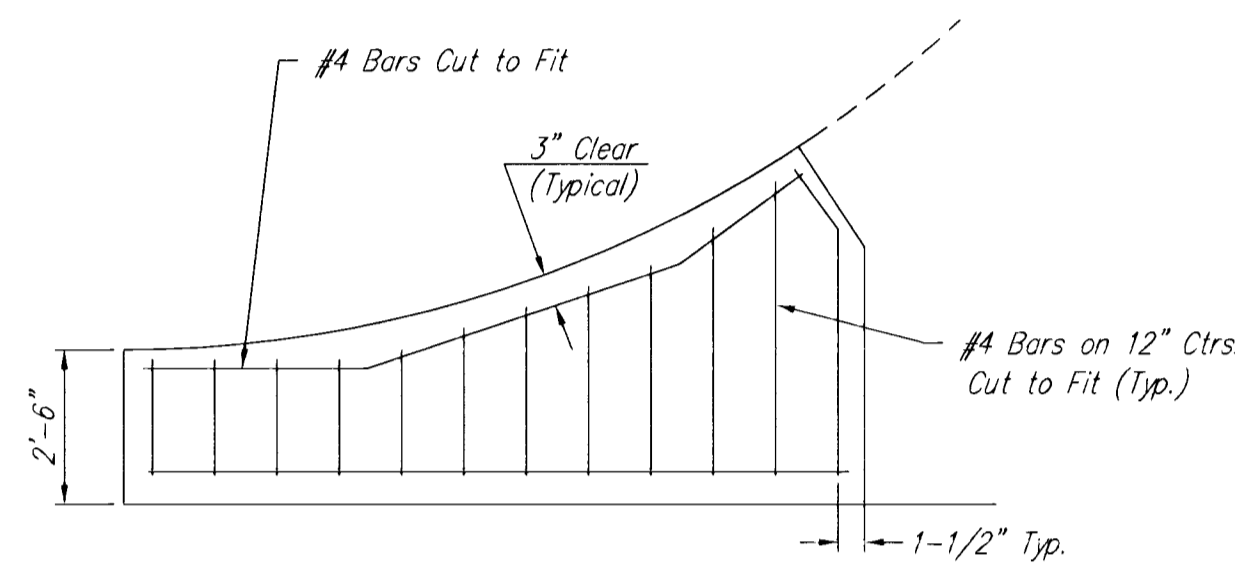

**WING REINFORCING DETAIL**

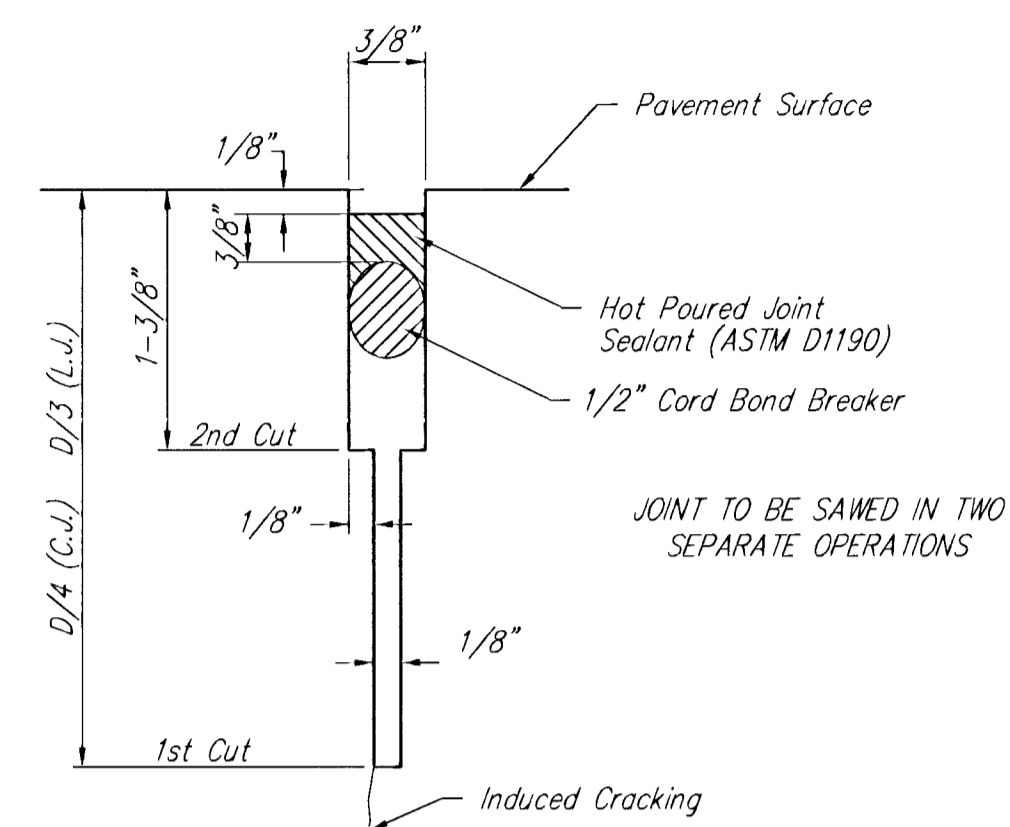

**SAW JOINT DETAIL**

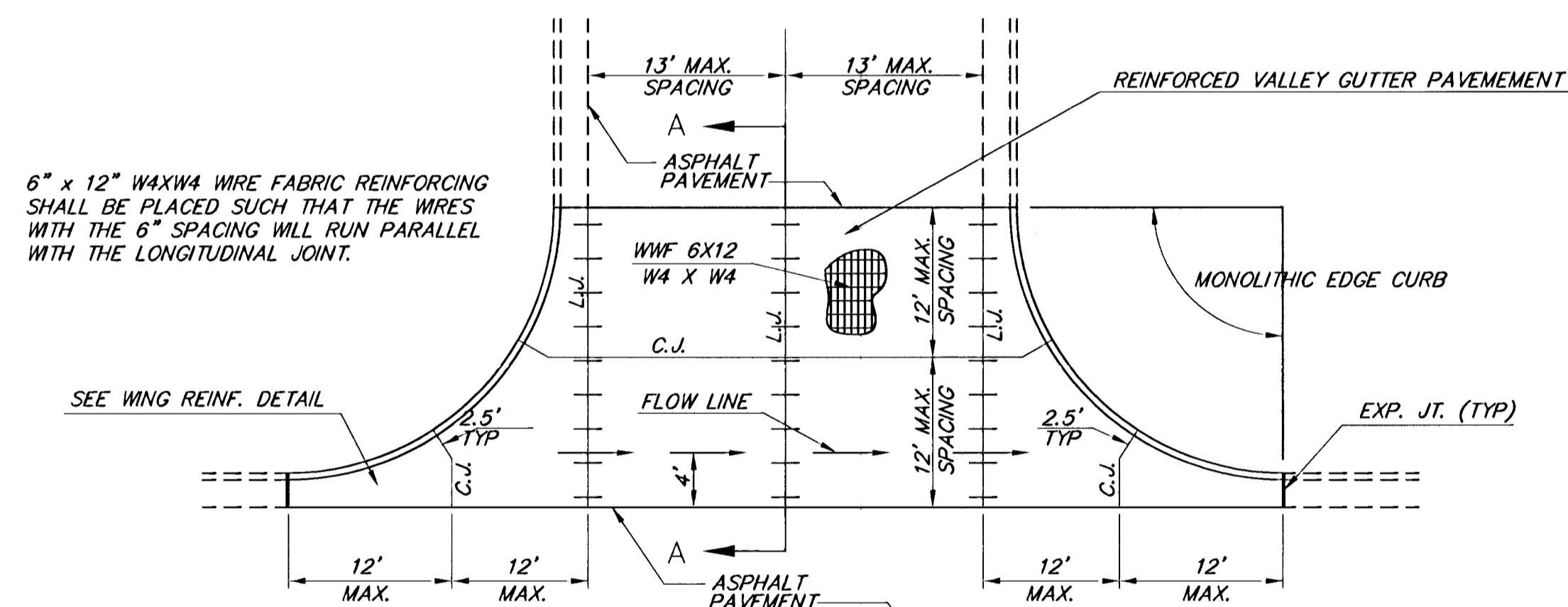

**PLAN**

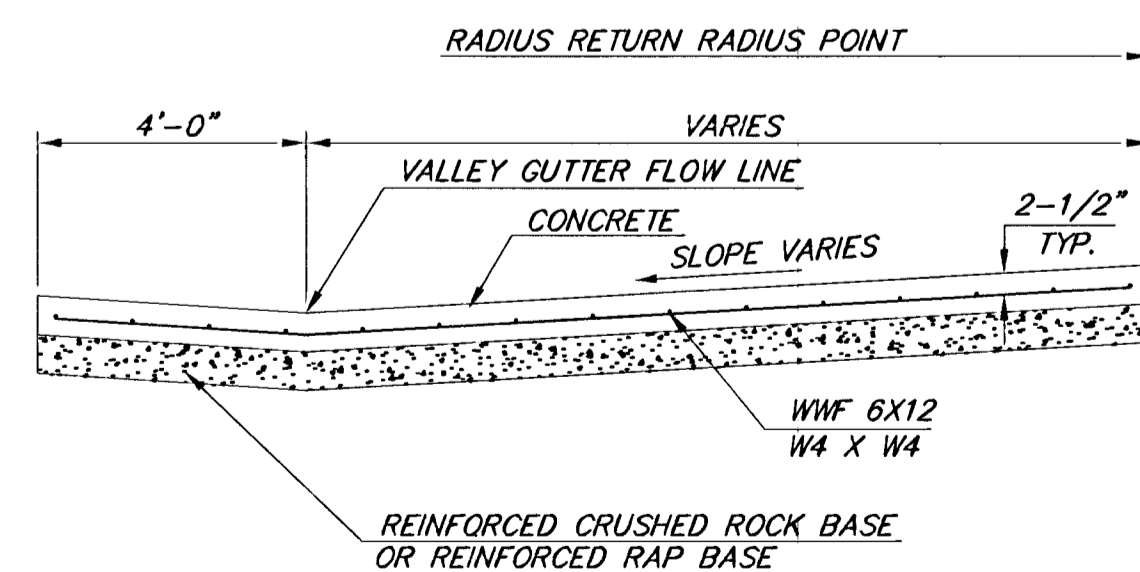

**SECTION A-A**

**REINFORCED VALLEY GUTTER DETAIL**

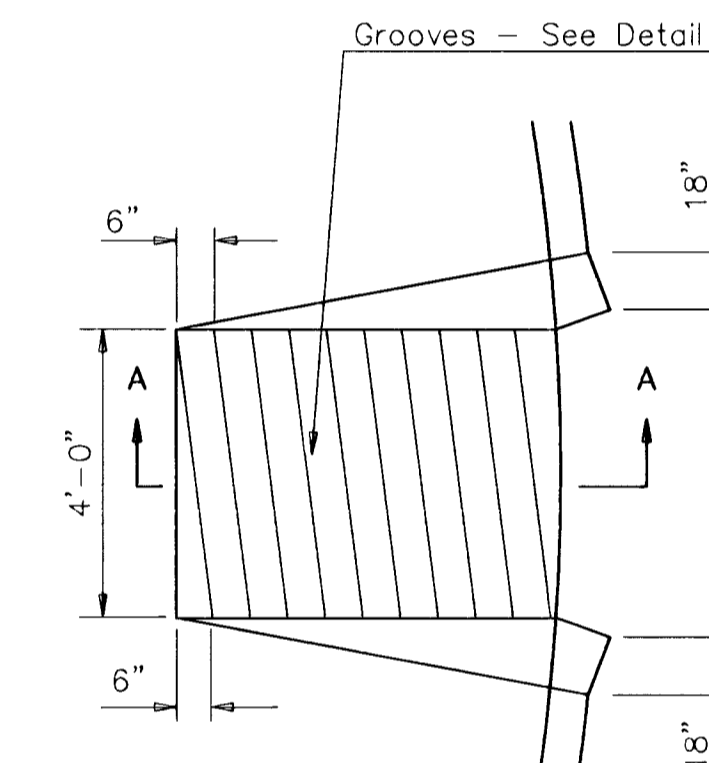

**WHEELCHAIR RAMP PLAN VIEW**

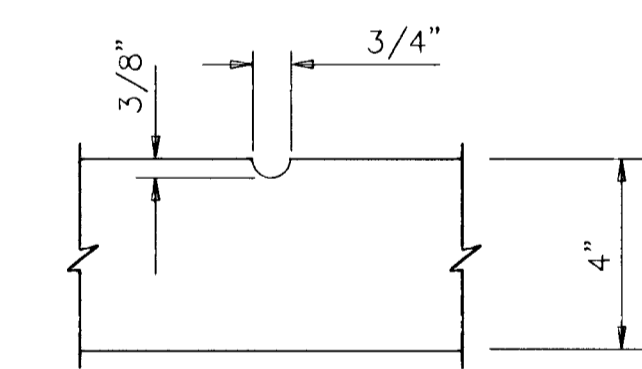

**GROOVE DETAIL**

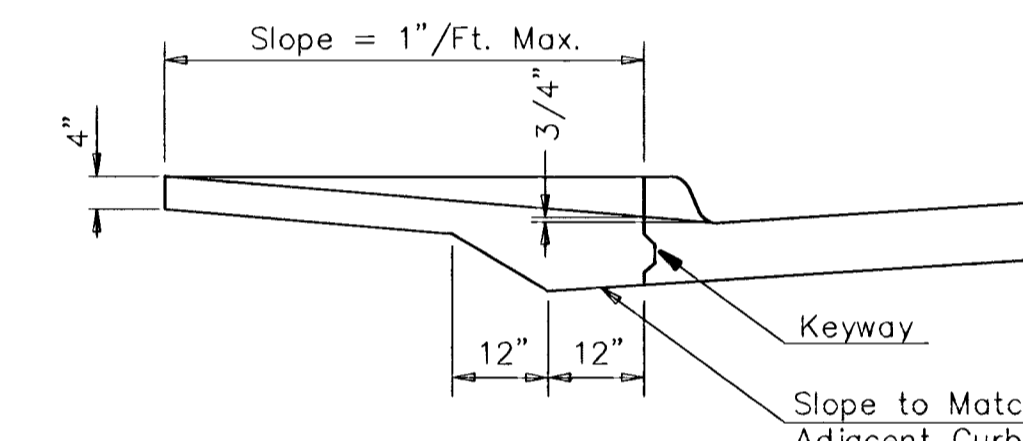

**SECTION A-A**

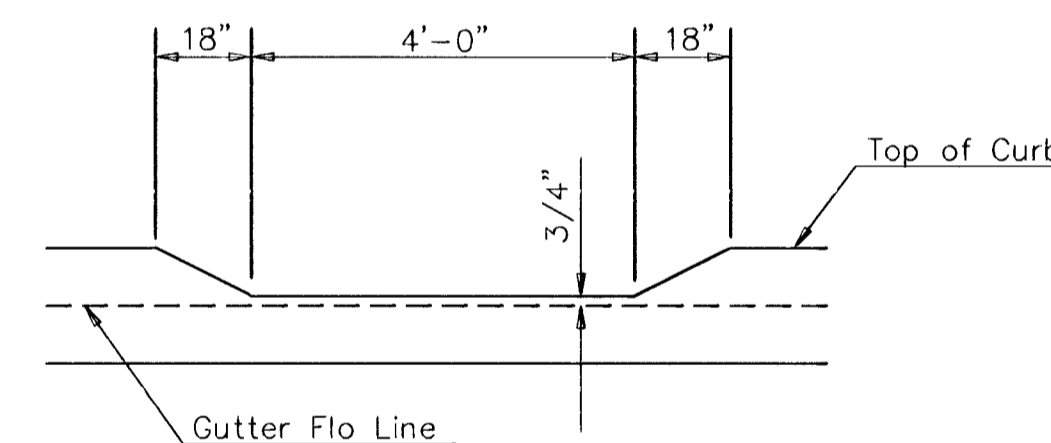

**DEPRESSED CURB DETAIL**

**WHEELCHAIR RAMP DETAIL**

<p>THE CITY OF WICHITA</p>	<b>VALLEY GUTTER DETAILS</b>	
	<b>WHEELCHAIR RAMP DETAILS</b>	
M. E. LINDEBAK P.E. - CITY ENGINEER		
PROJECT NUMBER		OCA #
DATE		SHEET 4 OF 21
CITY ENGINEER'S OFFICE CITY HALL - SEVENTH FLOOR 455 NORTH MAIN STREET WICHITA, KANSAS 67202 (316) 268-4501 (316) 268-4114 FAX		