

DRUMS AND TRIM LINE CHANNELIZERS SHALL BE RETROREFLECTORIZED FULL CIRCUMFERENCE WITH AT LEAST TWO ORANGE AND TWO WHITE 6' TO 8' WIDE STRIPES. ADDITIONAL STRIPES MAY BE NON-REFLECTIVE. IF THERE ARE NON-REFLECTIVE SPACES BETWEEN ADJACENT STRIPES, THEY SHALL BE NO MORE THAN 2' WIDE.

ALL RETROREFLECTIVE STRIPES ON DRUMS SHALL BE TYPE III HIGH PERFORMANCE SHEETING. THE WHITE STRIPES ON TRIM LINE CHANNELIZERS SHALL BE TYPE III HIGH PERFORMANCE SHEETING. PROJECTS LET AFTER JANUARY 1, 2002 WILL REQUIRE THAT THE ORANGE STRIPES ON ALL TRIM LINE CHANNELIZERS BE FLOURESCENT ORANGE PRISMATIC GRADE SHEETING.

FOR RAILS LESS THAN 36' LONG, 4' WIDE STRIPES MAY BE USED.

THE ENTIRE AREA OF BARRICADE RAILS, BOTH FRONT AND BACK, SHALL BE FULLY REFLECTORIZED WITH TYPE III HIGH PERFORMANCE RETROREFLECTIVE SHEETING.

THE STRIPES SHALL SLOPE DOWNWARD TO THE TRAFFIC SIDE FOR CHANNELIZATION.

THE ARROW PANEL SHALL BE BLACK ON FLUORESCENT ORANGE PRISMATIC GRADE SHEETING. THE STRIPES SHALL BE ORANGE AND WHITE TYPE III HIGH PERFORMANCE RETROREFLECTIVE SHEETING SLOPING DOWNWARD IN THE DIRECTION TRAFFIC IS TO PASS.

THE DIRECTION INDICATOR BARRICADE SHALL BE USED IN SERIES TO DIRECT THE MOTORIST INTO THE INTENDED LANE OF TRAVEL.

THE ARROW PANEL SHOULD NOT BE VISIBLE TO OPPOSING TRAFFIC.

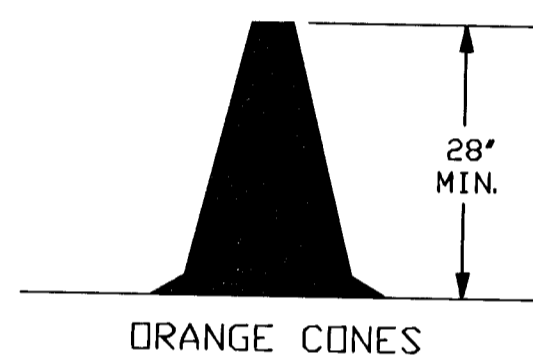

CONES MAY BE USED AS CHANNELIZING DEVICES FOR DAYTIME OPERATIONS ONLY. THEY WILL NOT BE PAID FOR SEPARATELY, BUT WILL BE SUBSIDIARY TO OTHER TRAFFIC CONTROL BID ITEMS. THE ENGINEER MAY REQUIRE THAT CONES BE SUPPLEMENTED BY OTHER TRAFFIC CONTROL DEVICES IN CERTAIN SITUATIONS.

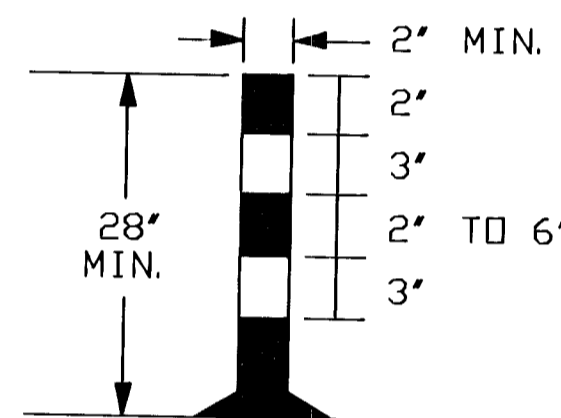

TUBULAR MARKERS

TAPER FORMULAS:

$$L = WS \text{ FOR SPEEDS OF 45 MPH OR MORE}$$

$$L = W^2 / 60 \text{ FOR SPEEDS OF 40 MPH OR LESS}$$

WHERE: L = MINIMUM LENGTH OF TAPER IN FEET
S = NUMERICAL VALUE OF POSTED SPEED PRIOR TO WORK STARTING IN MPH
W = WIDTH OF OFFSET IN FEET

CHANNELIZER PLACEMENT:

(A) THE SPACING BETWEEN DEVICES IN THE TAPER SHOULD NOT EXCEED A DISTANCE IN FEET EQUAL TO THE POSTED SPEED LIMIT IN MPH PRIOR TO WORK STARTING.

(B) THE SPACING BETWEEN DEVICES IN THE WORK ZONE SHOULD NOT EXCEED A DISTANCE IN FEET EQUAL TO TWO TIMES THE POSTED SPEED LIMIT IN MPH PRIOR TO WORK STARTING.

(C) CHANNELIZING DEVICES SHALL BE PLACED FOR OPTIMUM VISABILITY, NORMALLY AT RIGHT ANGLES TO THE TRAFFIC FLOW.

(D) CHANNELIZING DEVICES PLACED ALONG SHOULDER EDGES OR IN DROPOFFS SHALL HAVE A MINIMUM OF 24' FROM THE TOP OF THE CHANNELIZING DEVICE TO THE TOP OF THE PAVEMENT.

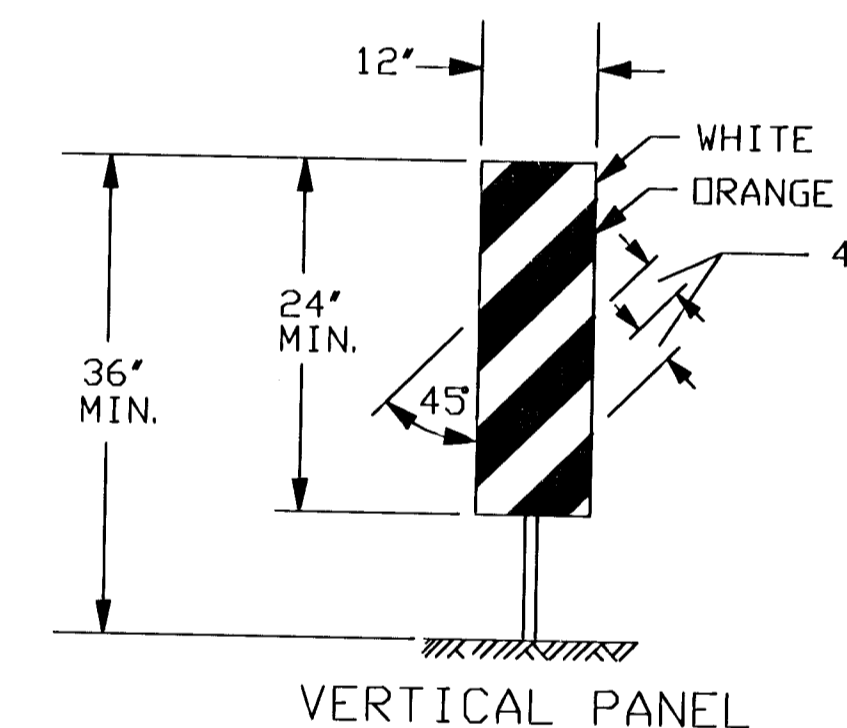

THE ENTIRE AREA OF VERTICAL PANELS, BOTH FRONT AND BACK, SHALL BE FULLY REFLECTORIZED WITH TYPE III HIGH PERFORMANCE RETROREFLECTIVE SHEETING. THE STRIPES SHALL SLOPE DOWNWARD TO THE TRAFFIC SIDE FOR CHANNELIZATION.

ITEM	LOCATION	CHANNELIZING DEVICES							
		CROSS-OVERS	DIVERSIONS	TANGENTS	TAPERS	RAMPS	HEAD TO HEAD	OBJECT IDENTIFIER	
PORTABLE	DRUMS	YES	YES	YES	YES	YES	(1)	YES	
	TRIM LINES	YES	YES	YES	YES	YES	(1)	YES	
	VERTICAL PANELS	(2)	(2)	(2)	(2)	(2)	(1, 2)	YES	
	DIRECTION INDICATOR BARRICADE	NO	NO	NO	YES	NO	NO	NO	
	TYPE II BARRICADE	(2)	(2)	(2)	(2)	NO	NO	YES	
FIXED									
	TUBULAR MARKERS	(3)	(3)	(3)	NO	(3)	YES	NO	
	VERTICAL PANELS	(3)	(3)	(3)	(3)	(3)	(3)	YES	

(1) Not allowed on centerline delineation along freeways or expressways.

(2) Slashes must slope down toward direction traffic is to pass.

(3) May be used upon the approval of the Engineer.

3				
2	9-26-02	MODIFIED NOTES	M.H.	S.A.B.
1	11-13-01	REVISED CHANNELIZING DEVICE MATRIX	J.H.	S.A.B.
NO.	DATE	REVISIONS	BY	APP'D

KANSAS DEPARTMENT OF TRANSPORTATION
CHANNELIZING DEVICES