

**BENCHMARKS:**

"□" Cut in middle of N headwall of RBCB on 21st St. North. 1004.3' W & 22.1' N of SE Cor., SE1/4, Sec. 2, T-27-S, R-2-E. Elev. = 173.23 City Datum

RR spike in N. face of power pole 840.0' west of C.L. of Castle Rock and 48.7' south of C.L. of 21st St. N. Elev. = 182.03 City Datum

Scale: 1" = 20' Horizontal  
1" = 5' Vertical  
• = Iron

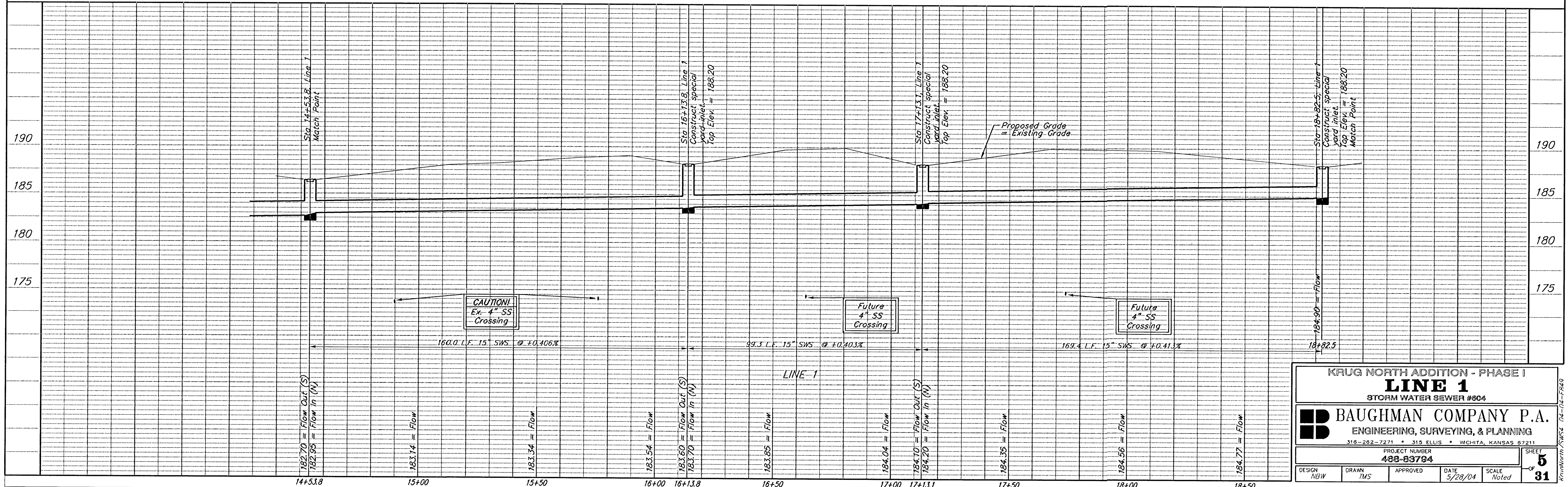
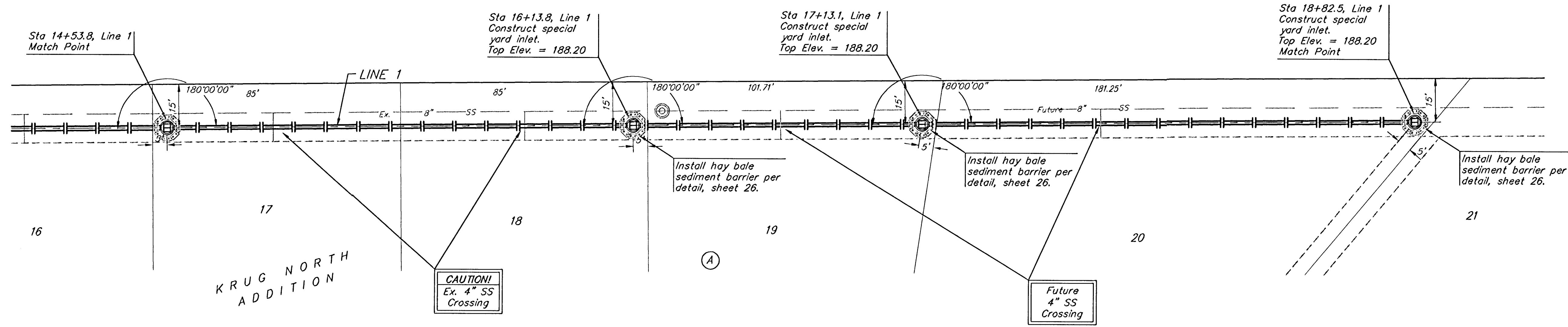

**KRUG NORTH ADDITION - PHASE I**  
**LINE 1**  
STORM WATER SEWER #804

**BAUGHMAN COMPANY P.A.**  
ENGINEERING, SURVEYING, & PLANNING  
318-262-7271 • 315 ELLIS • WICHITA, KANSAS 67211

PROJECT NUMBER: **488-83794**

DESIGN: NGW	DRAWN: TMS	APPROVED:	DATE: 3/28/04	SCALE: Noted
-------------	------------	-----------	---------------	--------------

SHEET **5** OF **31**