

BENCHMARKS:

"□" Cut in middle of N headwall of RCBC on 21st St. North, 1004.3' W & 22.1' N of SE Cor., SE 1/4, Sec. 2, T-27-S, R-2-E. Elev. = 173.23 City Datum

RR spike in N. face of power pole 840.0' west of C.L. of Castle Rock and 48.7' south of C.L. of 21st St. N. Elev. = 182.03 City Datum



Scale: 1" = 20' Horizontal
1" = 5' Vertical
• = Iron

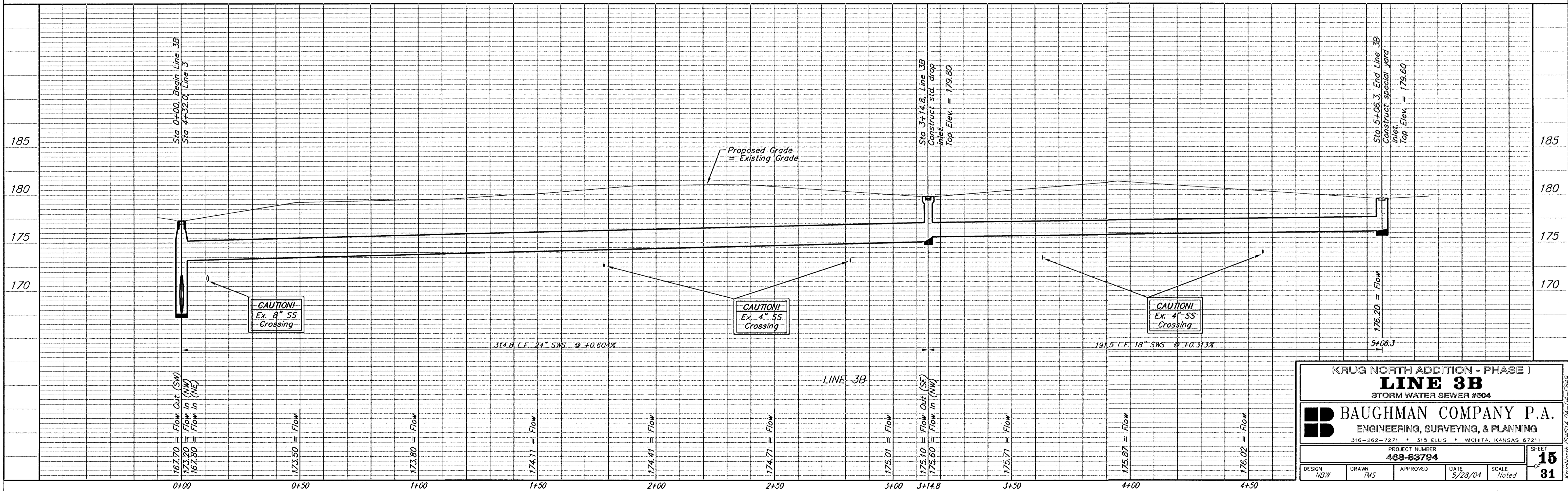
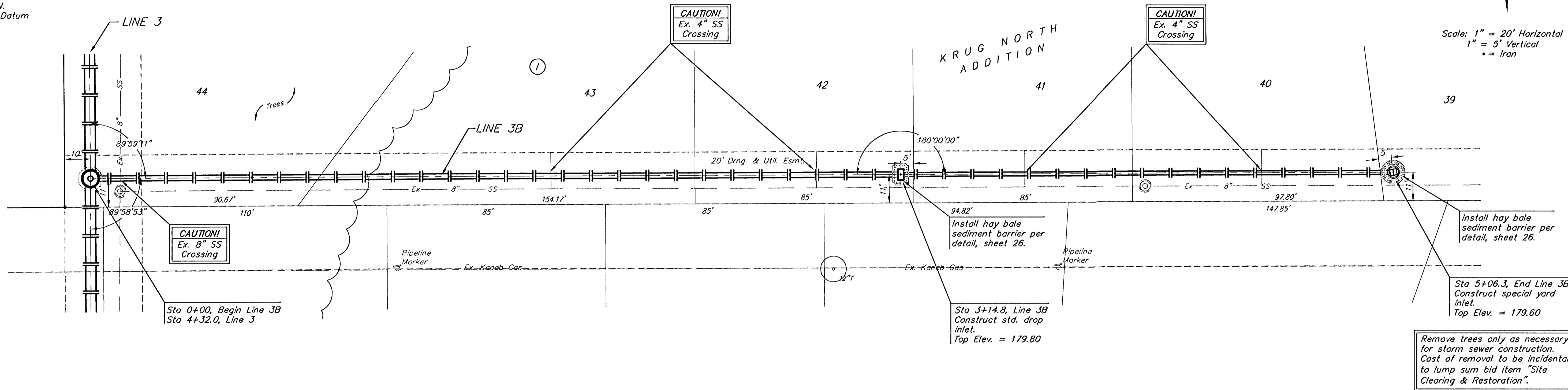

KRUG NORTH ADDITION - PHASE I
LINE 3B
STORM WATER SEWER #504

BAUGHMAN COMPANY P.A.
ENGINEERING, SURVEYING, & PLANNING
316-282-7271 • 315 ELLIS • WICHITA, KANSAS 67211

PROJECT NUMBER
488-83784

DESIGN NBW	DRAWN TMS	APPROVED	DATE 5/28/04
			SCALE Noted

SHEET
15
OF
31