

8 SLAT WALL DETAIL
1 1/2" = 1'-0"

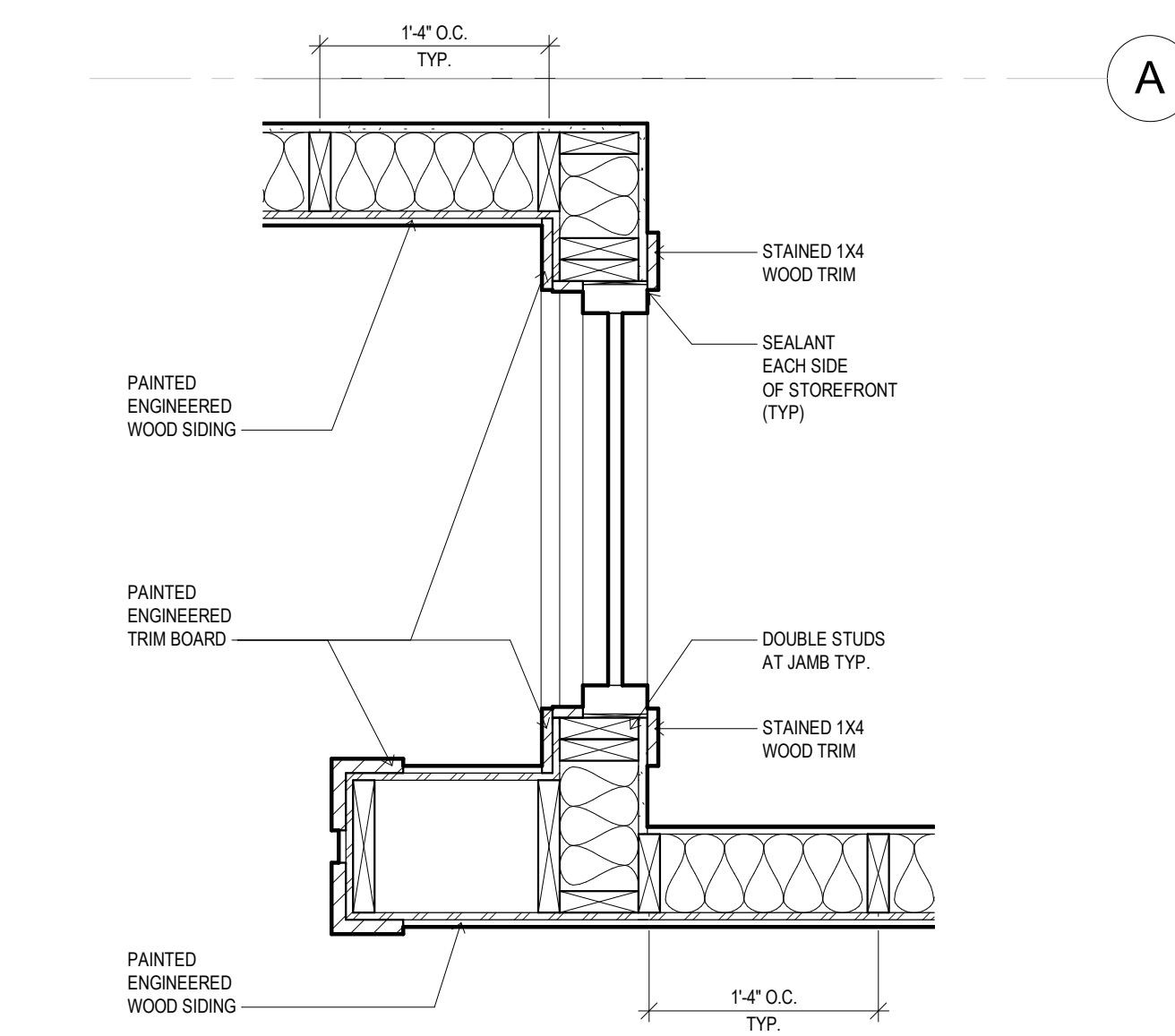

7 PLAN DETAIL AT GREAT ROOM ALCOVE
1" = 1'-0"

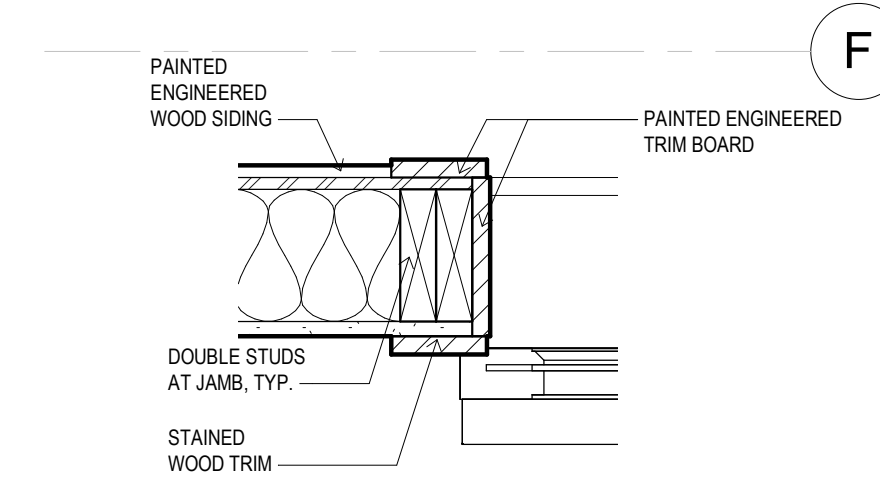

5 O.H. DOOR JAMB DETAIL
1 1/2" = 1'-0"

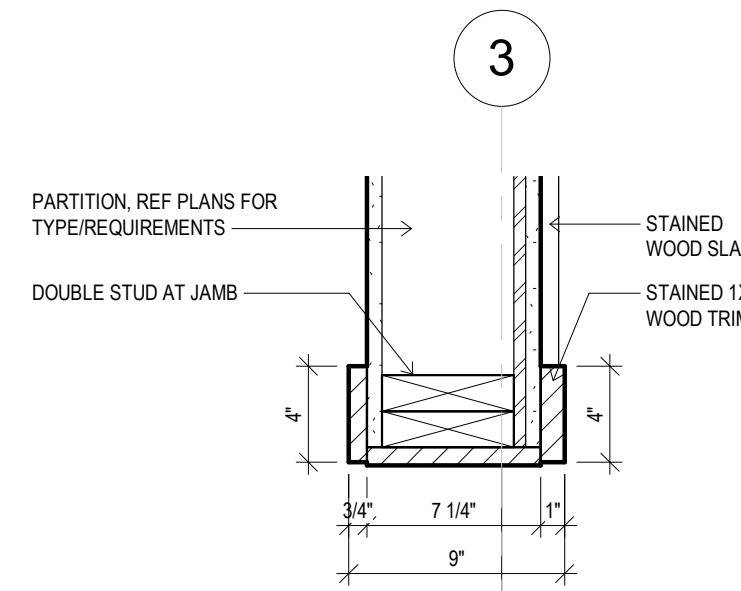

4 SLAT WALL JAMB DETAIL
1 1/2" = 1'-0"

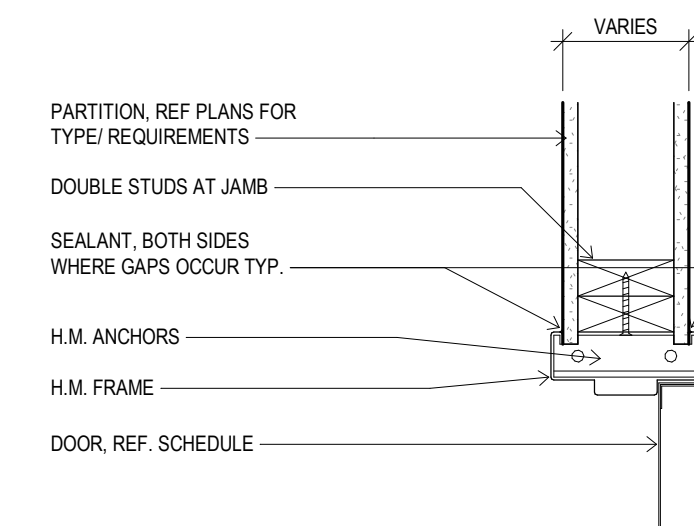

3 TYP. DOOR JAMB DETAIL
1 1/2" = 1'-0"

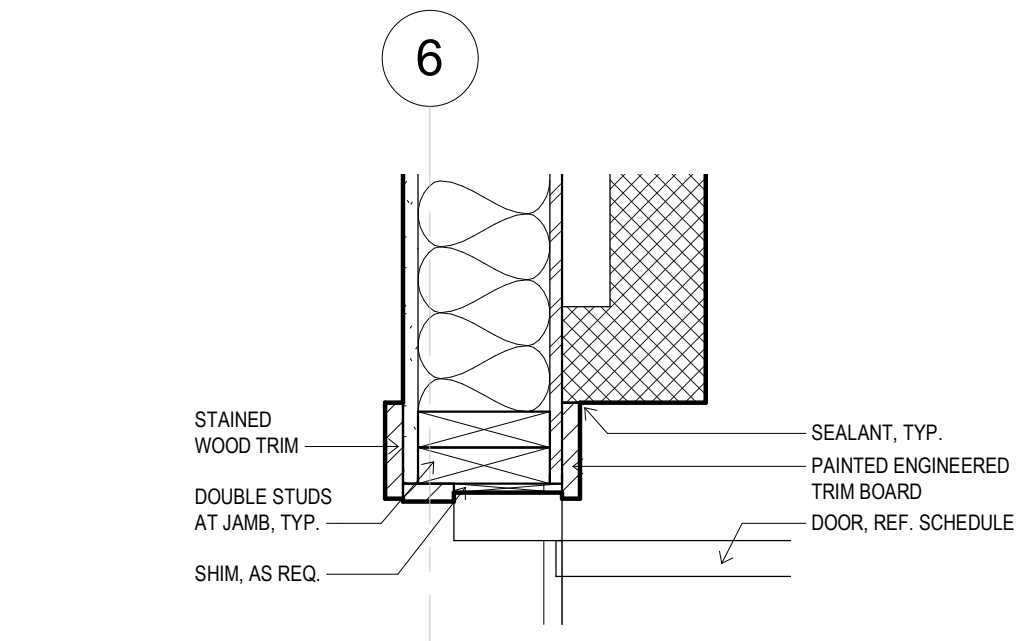

6 STOREFRONT DOOR JAMB DETAIL
1 1/2" = 1'-0"

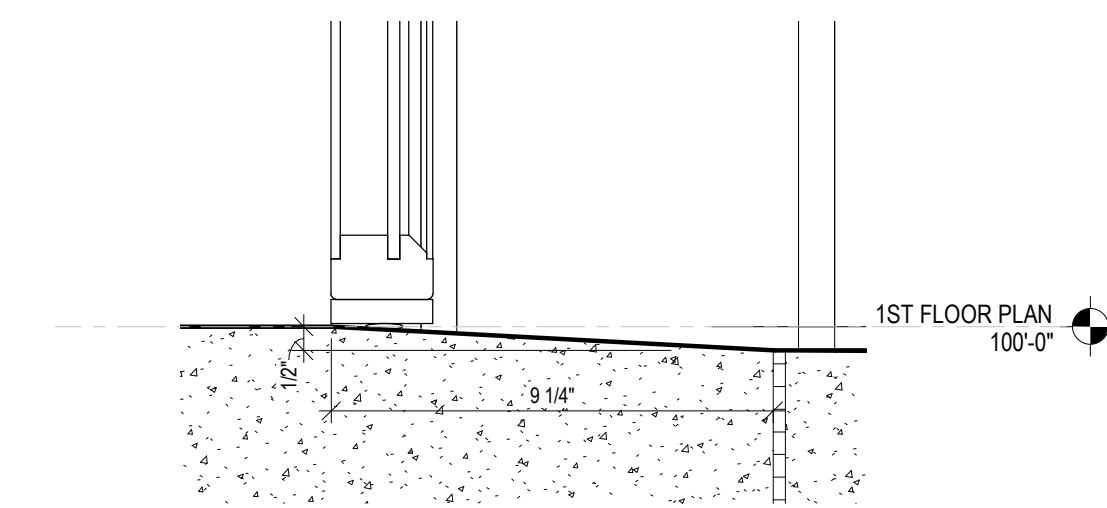

2 SLAB STEP AT O.H. DOOR
3" = 1'-0"

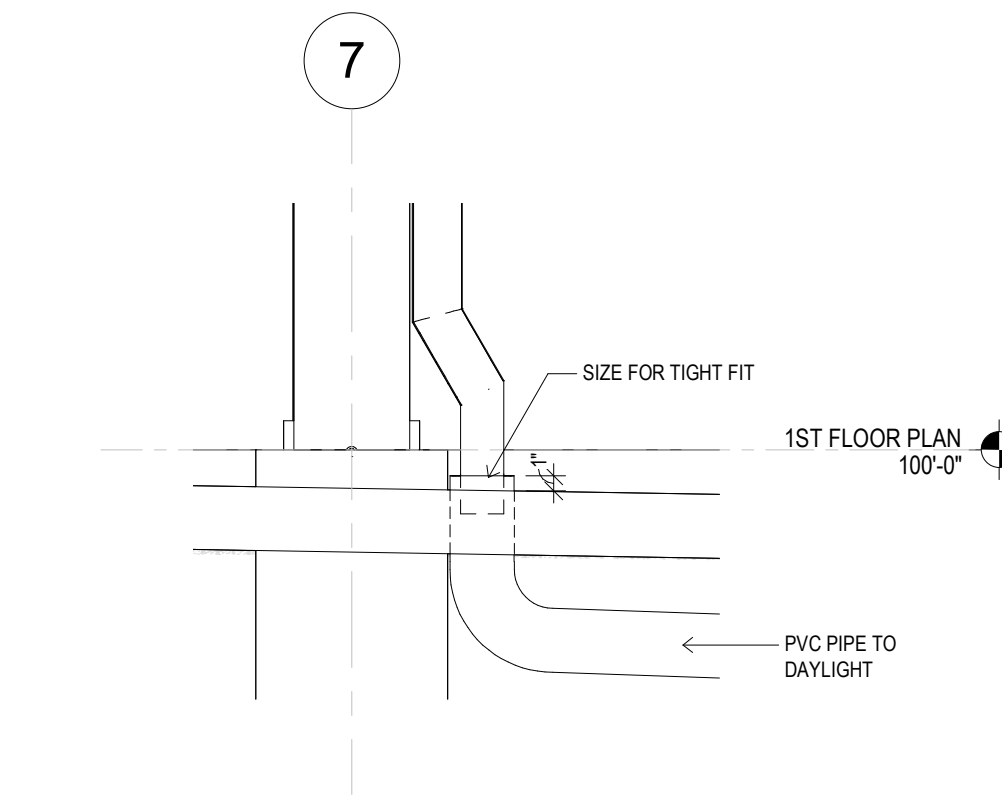

1 PVC PIPE TO DAYLIGHT
1" = 1'-0"