

ROCK SHOULDER SPECIFICATIONS:
Follow KDOT Specs (See Section 1113 - Aggregates for Shoulder Construction)

PAVEMENT SPECS:
BM-2
PG 64-22 (Base)
PG 70-28 (Surface)

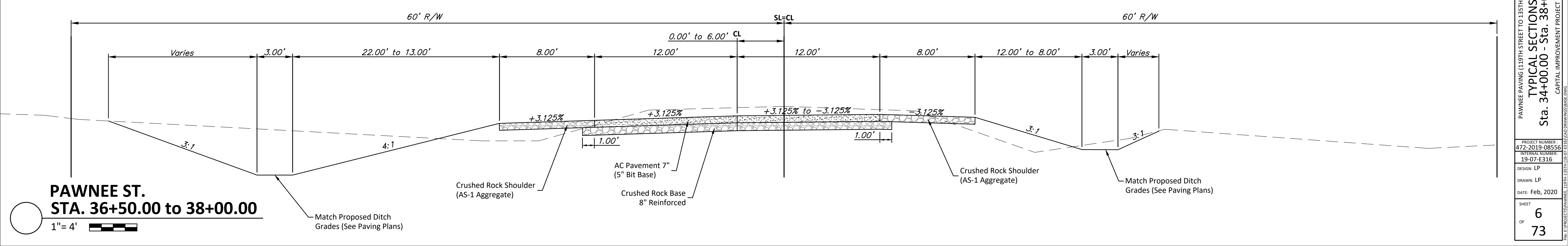
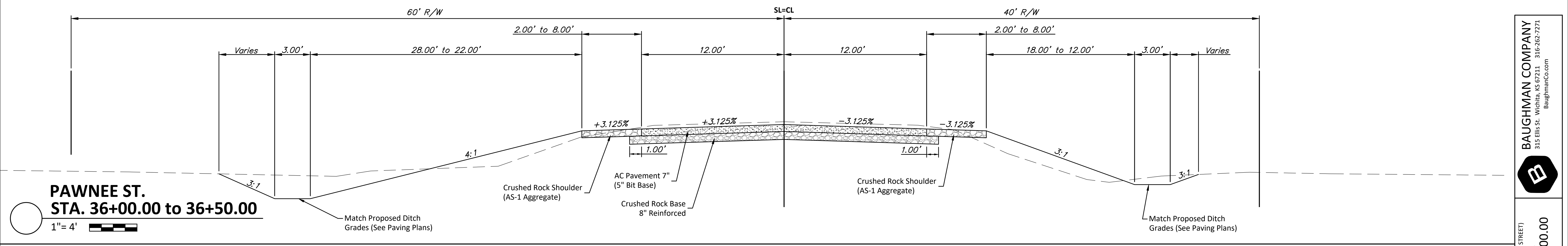
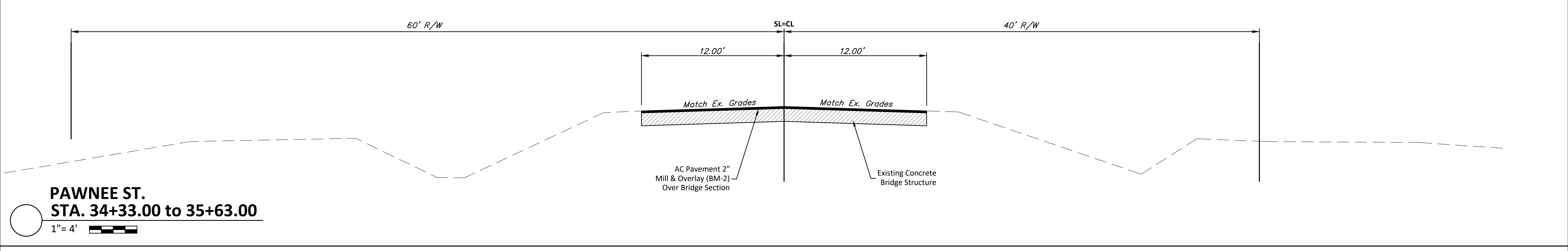

BAUGHMAN COMPANY
315 Ellis St. Wichita, KS 67211 316-262-7771
BaughmanCo.com

PAWNEE PAVING (119TH STREET TO 135TH STREET)
TYPICAL SECTIONS
Sta. 34+00.00 - Sta. 38+00.00
CAPITAL IMPROVEMENT PROJECT

PROJECT NUMBER: 472-2019-08556
INTERNAL NUMBER: 19-07-E316
DESIGN: LP
DRAWN: LP
DATE: Feb, 2020
SHEET: 6 OF 73