

- NOTES**
- This detail covers Butterfly Valve installation, inclusive, regardless of type of pipe or joint used. Larger lines to be detailed on plans.
 - 6" Valve Box and Cover required per City of Wichita Std. Specifications.
 - Conc. Support Block to be full width of trench.

CONCRETE SUPPORT BLOCKING FOR BUTTERFLY VALVE INSTALLATION

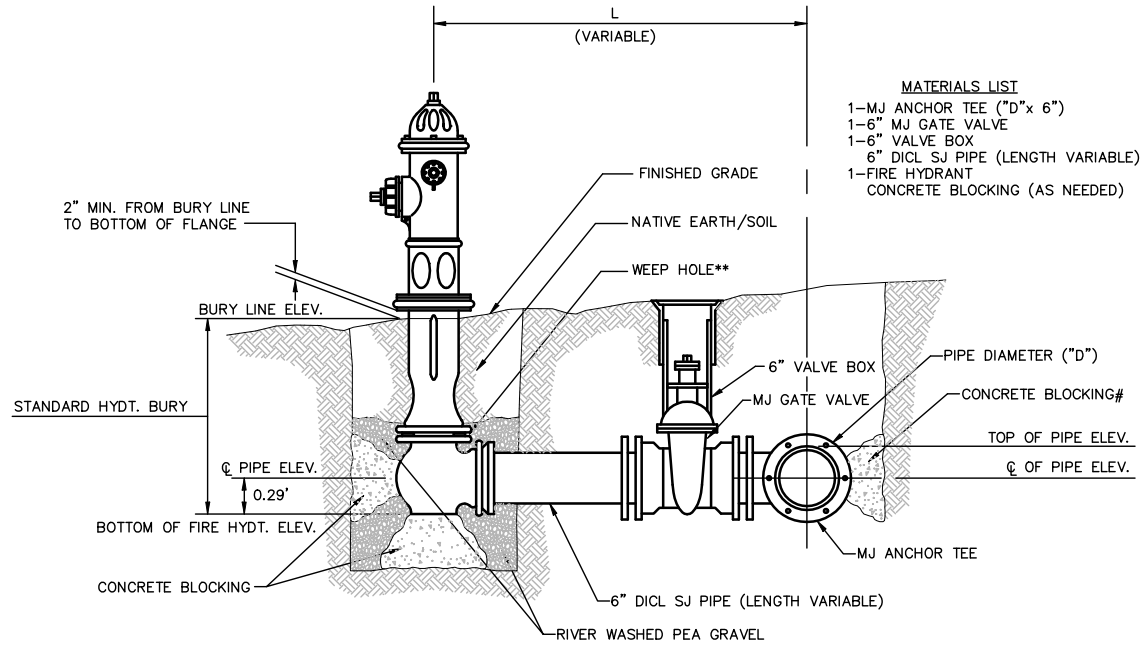

FIRE HYDRANTS REQUIRED

LINE	STATION	BURY LINE ELEVATION	TOP OF PIPE ELEVATION	FIRE HYDRANT BURY REQUIRED*

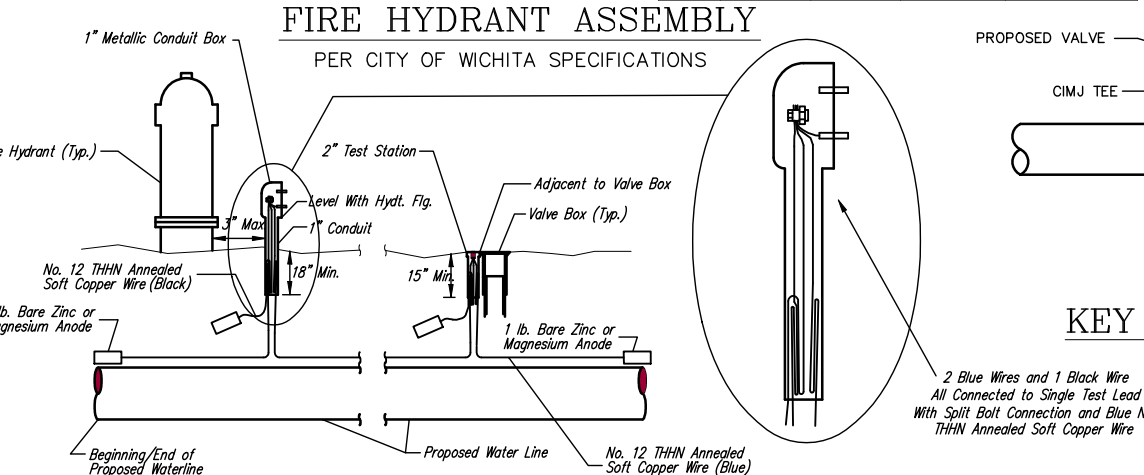

TRACER WIRE DETAIL
 COST IS SUBSIDIARY TO PIPE INSTALLATION

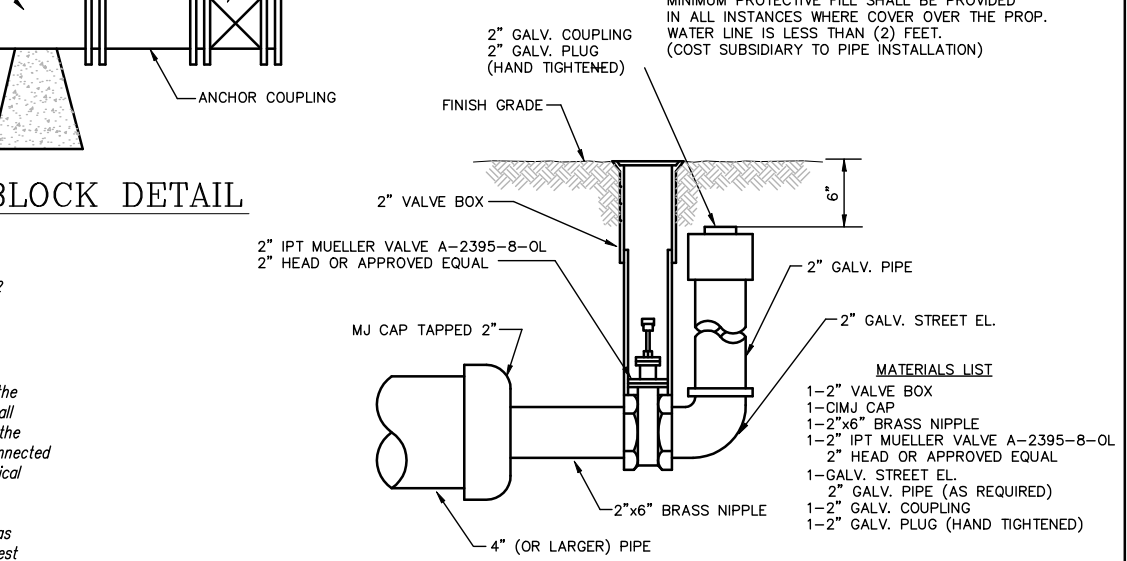
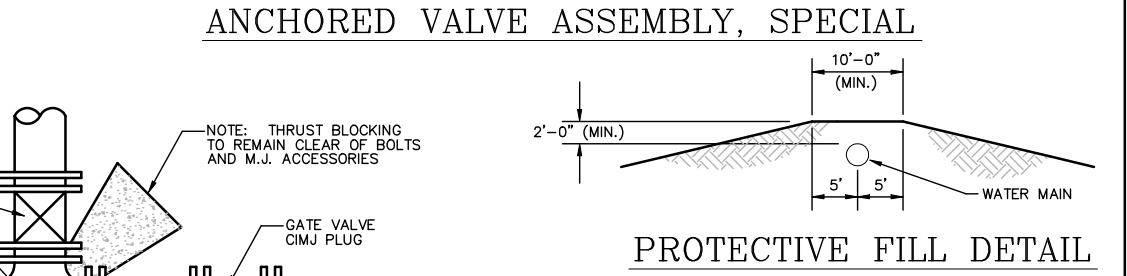
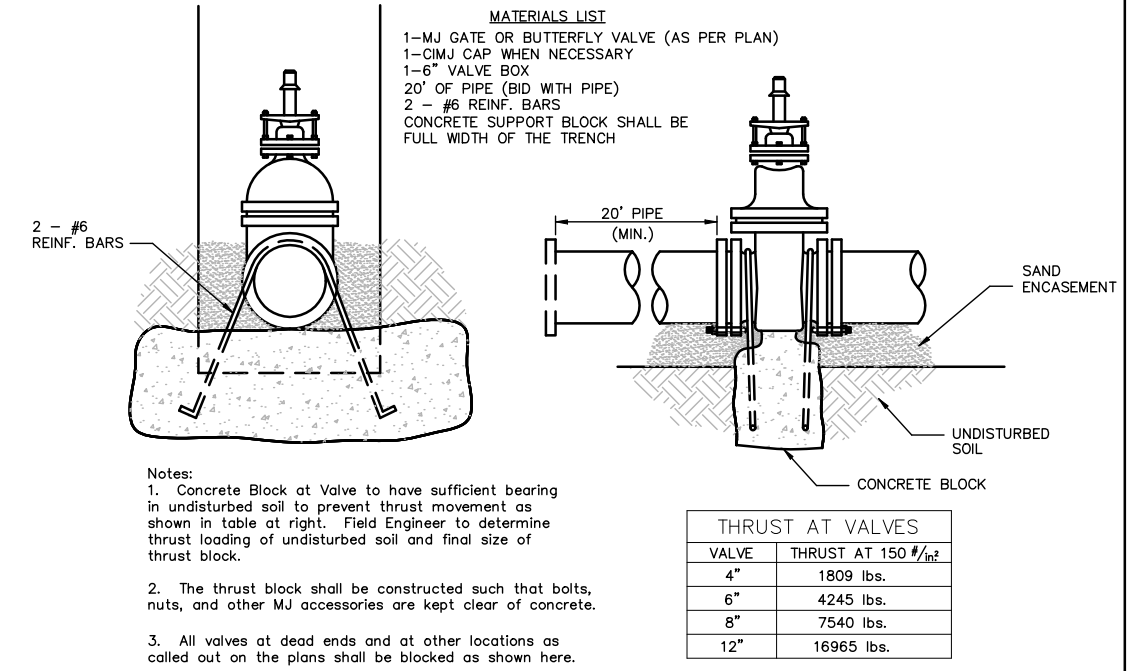

2" BLOWOFF ASSEMBLY

THE CITY OF WICHITA

STANDARD WATER ASSEMBLY DETAILS

James L. Armor, P.E. City Engineer

CITY ENGINEER'S OFFICE
 435 NORTH MAIN STREET
 WICHITA, KANSAS 67202
 (316) 268-4201
 (316) 268-4114 FAX

PROJECT NUMBER: 448-90274
 INDEX CODE: 735356

DATE: APRIL 2007
 SHEET 2 OF 3

Revised: 6-7-00, MCG