

4" thru 8" Fire Service

Use 45 degree fittings as necessary to keep depth of vault within 76 inch maximum. All fittings should be mega lug, restrained joint or approved equal. All fittings for vertical and horizontal adjustments are to be on private property.

- A - Mega Lug (See Note 7)*
- B - Min. 3'-8" Piece of FL x PE DICL Pipe*
- C - Flange Gate Valve, Wheel Operated*
- D - Ames Model 3001SS or approved equal with metered (cubic foot) by-pass assembly*

NOTE:
Domestic Services larger than 6" shall be custom designed by Consultant Engineer.

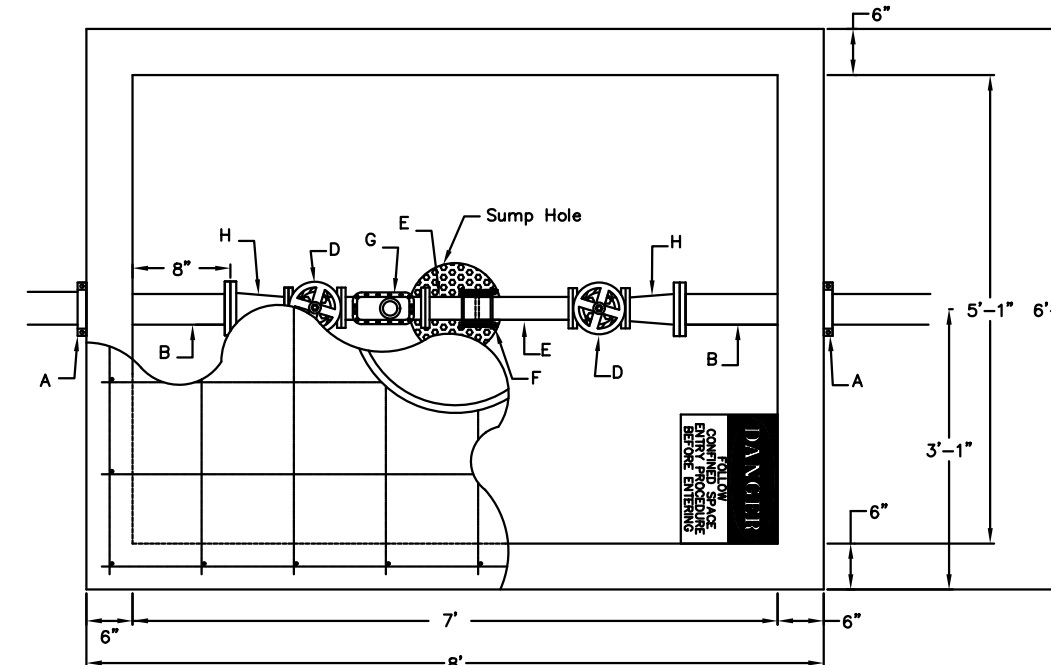
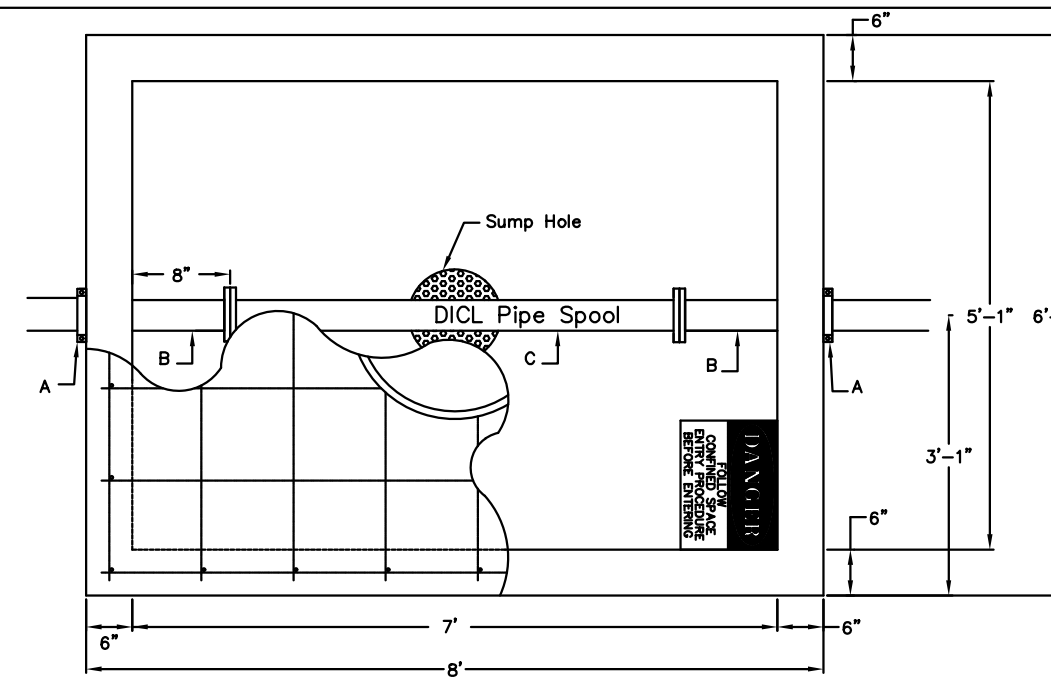

3" Domestic Service

- A - 4" Vault Clamp*
- B - Min. 3' Piece of 4" FL x PE DICL Pipe*
- C - 4" DICL Flanged Pipe Spool*
- D - 3" Flange Non-rising Stem Gate Wheel Valve**
- E - 3" FL x PE Pipe**
- F - 3" Flex Coupling**
- G - 3" Badger Recordall II Turbo Cubic Foot Meter with AMR Register with a ADE on the register.**
- H - 3" x 4" FL Reducer**

* = Contractor Installed
** = Installed By Wichita Water Utilities

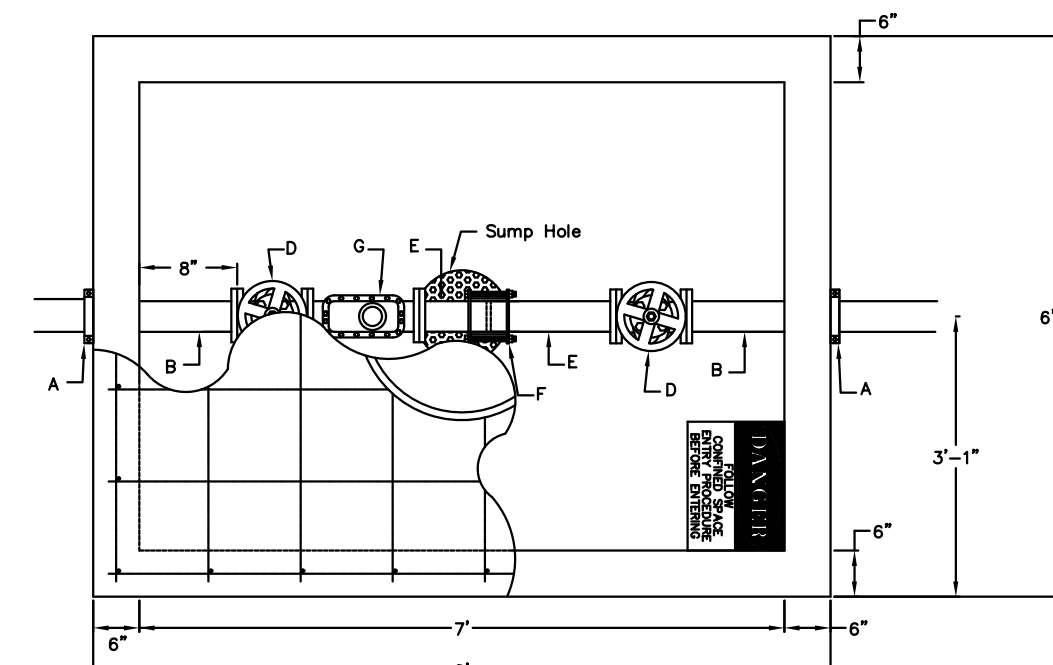
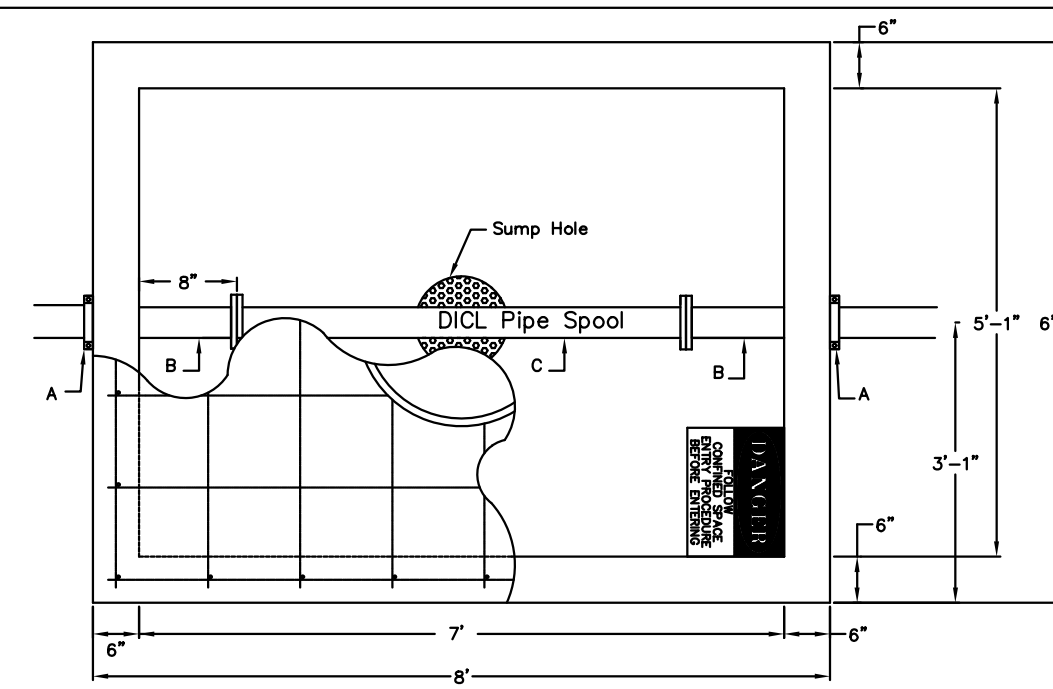

4" Domestic Service

- A - 4" Vault Clamp*
- B - Min. 3' Piece of 4" FL x PE DICL Pipe*
- C - 4" DICL Pipe Spool*
- D - 4" Flange Non-rising Stem Gate Wheel Valve**
- E - 4" FL x PE Pipe**
- F - 4" Flex Coupling**
- G - 4" Badger Recordall II Turbo Cubic Foot Meter with AMR Register with a ADE on the register.**
- H - 3" x 4" FL Reducer**

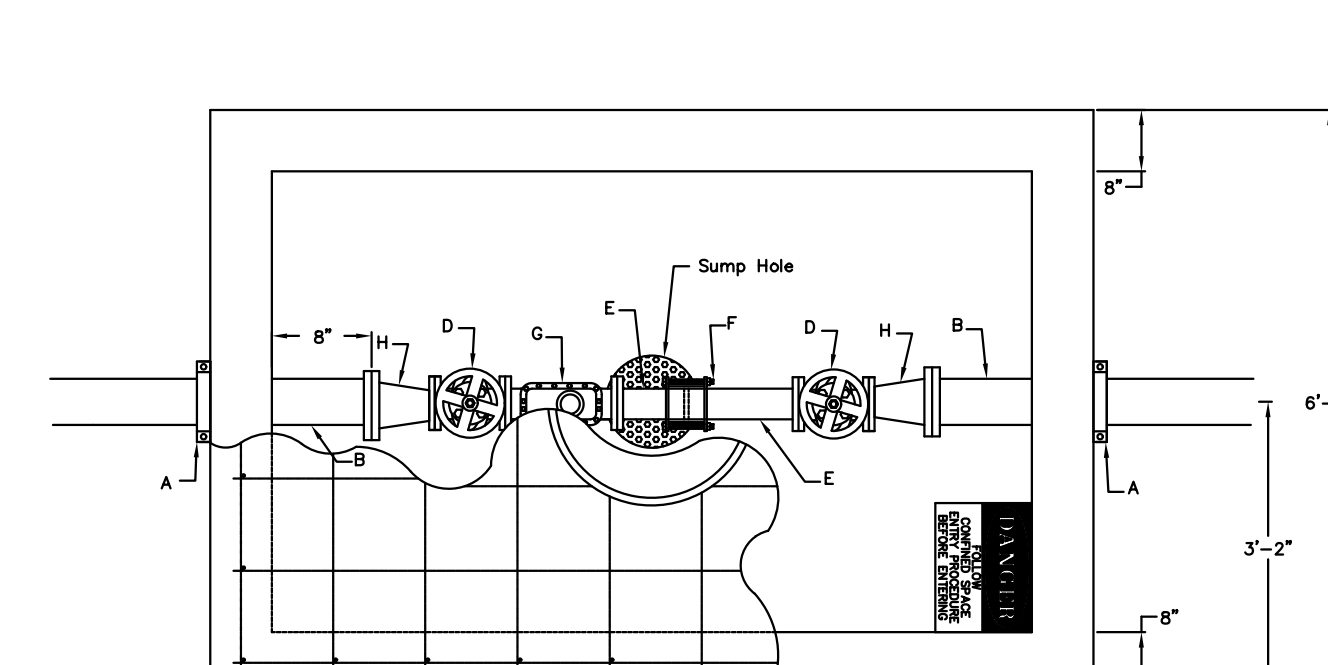
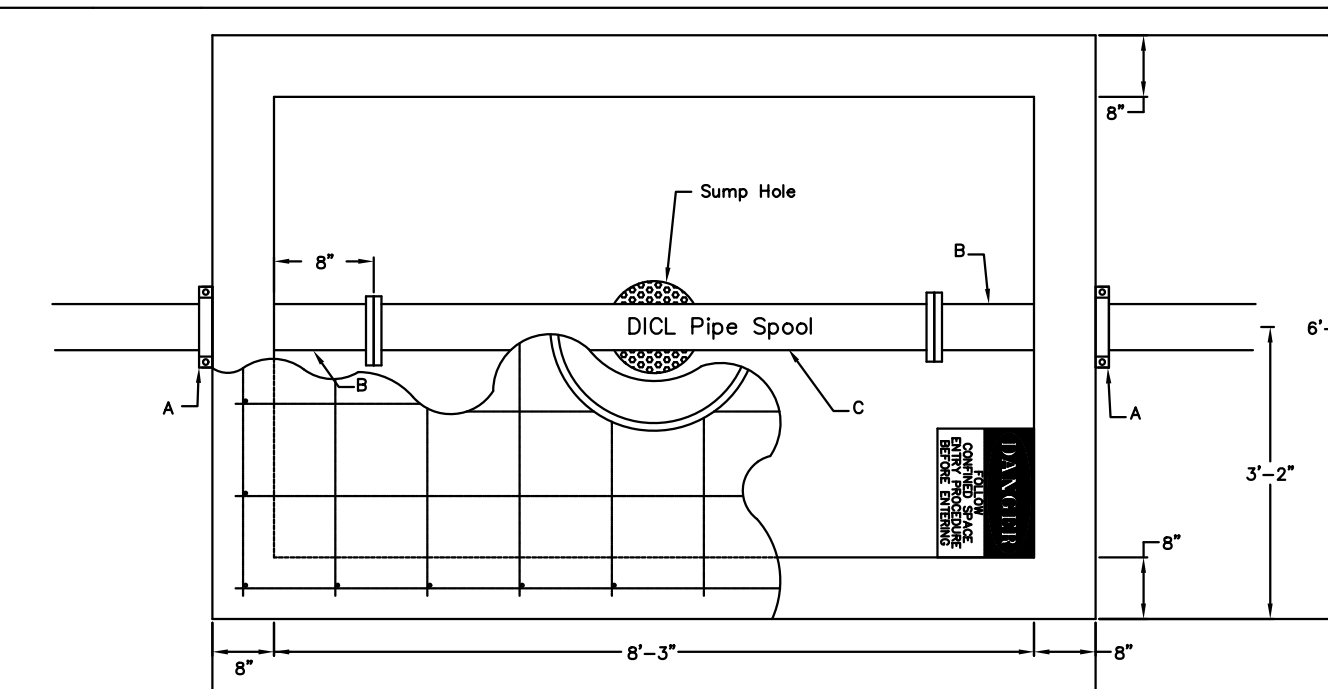

6" Domestic Service with 4" meter

- A - 6" Mega Lug (See Note 7)*
- B - Min. 3' Piece of 6" FL x PE DICL Pipe*
- C - 6" DICL Pipe Spool*
- D - 4" Flange Non-rising Stem Gate Wheel Valve**
- E - 4" FL x PE Pipe**
- F - 4" Flex Coupling**
- G - 4" Badger Recordall II Turbo Cubic Foot Meter with AMR Register with a ADE on the register.**
- H - 6" x 4" FL Reducer**

- Notes For All Services - 3" thru 12":
- When the standard vault dimensions are not applicable, such as when additional space is required for special pipe, fittings, additional meters, etc. the consultant design engineering shall design a vault with the required dimensions for Public Works and Utilities approval.
 - The vault shall be poured concrete, cement blocks (voids to be completely filled with 2500 P.S.I. concrete), or approved precast structure. The intent of these details shall not be limited by drawings or standards of precast structures.
 - Any vault located in pavement must be traffic rated unless it is protected. Traffic rated vaults must be design and approved by Public Works and Utilities.
 - The manhole ring and lid shall be Neenah R-6034 Frame with Type "C" Solid Lid and Drop Down Handle or US Foundry APS-30x30 (Aluminum) or Deeter 1261 or EJ 1936z1 (with pick hole(s) as shown in Detail A). Where applicable the standard 10" Public Works and Utilities pattern meter reading lid and ring shall be located directly above water meter register. All joints of concrete to concrete or metal to concrete in the construction of the vault shall have a approved water tight mastic joint seal.

- Any fittings or appurtenances required to achieve proper elevation of pipe through the vault shall be provided by the contractor and appropriately noted on the as-builts submitted by the inspecting engineer. Such fittings shall be a minimum of 2' from the exterior wall of vault.
- For all domestic services larger than 3" the contractor shall provide an outlet flange connection as shown 8" from the inside wall. Inlet and outlet wall sleeves shall be provided and installed by the contractor and shall be in alignment with one another. The inlet and outlet pipe shall be ductile iron pipe, cement lined, Class 150 per Standard Specifications and shall be continuous through vault and joint no less than 2' from the exterior wall of vault. Flanges of inlet and outlet pipe shall be in proper alignment and bolt pattern shall be rotated in such a way that valves and other fittings shall be in their proper vertical alignment when installed.
- For all services 4" and larger the contractor shall install a mega lug, restrained joint, or approved equal on the exterior walls of the vault, which shall be manufactured of ductile iron conforming ASTM A 536-80, heat treated to a minimum hardness of 370 BHN and have a working pressure of a least 250 P.S.I. For a services smaller than 4" the contractor shall install an approved vault clamp on the exterior walls of the vault.
- All valves, meters, assemblies and fitting shall be provided with sufficient concrete or other approved supports to the vault floor.
- The "Confined Space Warning" sign shall be fastened to the top of all vaults. If necessary for landscaping or site consideration, the sign may be fastened to the vault lid if it does not impede access to the handle. Acceptable materials: Aluminum 73415HH, Plastic 73439HH or S.A. Vinyl 73463HH.
- For all domestic services larger than 3" the contractor shall provide an outlet flange connection as shown 8" from the inside wall. Inlet and outlet wall sleeves shall be provided and installed by the contractor and shall be in alignment with one another. The inlet and outlet pipe shall be ductile iron pipe, cement lined, Class 150 per Standard Specifications and shall be continuous through vault and joint no less than 2' from the exterior wall of vault. Flanges of inlet and outlet pipe shall be in proper alignment and bolt pattern shall be rotated in such a way that valves and other fittings shall be in their proper vertical alignment when installed.
- All valves, meters, assemblies and fitting shall be provided with sufficient concrete or other approved supports to the vault floor.
- The "Confined Space Warning" sign shall be fastened to the top of all vaults. If necessary for landscaping or site consideration, the sign may be fastened to the vault lid if it does not impede access to the handle. Acceptable materials: Aluminum 73415HH, Plastic 73439HH or S.A. Vinyl 73463HH.
- All meters shall have a electronic read register compatible with the current City of Wichita meter reading system. All detector meters shall be on 5/8 cubic foot Badger meter with AMR register with a ADE on the register and 25' long Itron cord and plug or approved equal. Gallon meters shall not be accepted.
- Additional Notes For Fire Services
 - A post indicator valve (PIV) is an option for the outlet valve. It is not required by the City of Wichita ordinance, it can be requested by the owner and will be allowed at the discretion of the City Engineer.
 - When Siamese connections are required by the Wichita Fire Department, refer to the current City Code Section 15.
 - If due to any reason the completed vault retains ground or drainage water in excess of 4" in depth from the floor of the vault, the property owner shall be responsible for providing and installing a appropriate automatic sump pump or approved equal, as well as any other appurtenances required to make such system function as intended.

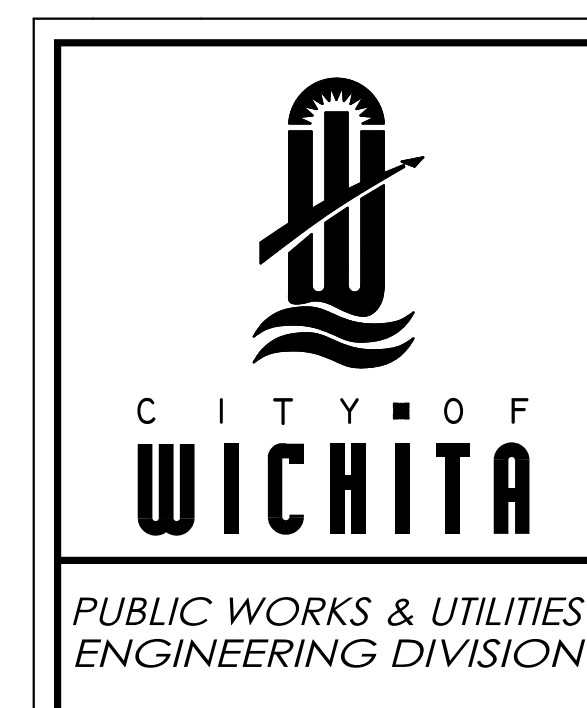

STANDARD VAULT DETAILS AND METER ASSEMBLIES

CITY ENGINEER
GARY JANZEN, P.E.

PROJECT NUMBER	OCA NUMBER	DATE
472-85463	707144	6/1/2020

CITY ENGINEER'S OFFICE	SHEET
CITY HALL - SEVENTH FLOOR 455 NORTH MAIN STREET WICHITA, KANSAS 67202-1620 (316) 268-4501	76 of 97

REVISED: OCTOBER 2016