

NOTE: Pipe Measured to Center of Inlets and Manholes. Pipe Measured to Nose of End Sections. End Sections to be Subsidiary to Pipe Quantity. Pipe Measured to Back of Headwalls. Back of Headwalls to be the Start & End of Stationing. Nose of End Sections be the Start & End of Stationing.

NOTE: Redefining Ex. Swale and All Grading Required to be SUBSIDIARY to Pipe Quantities

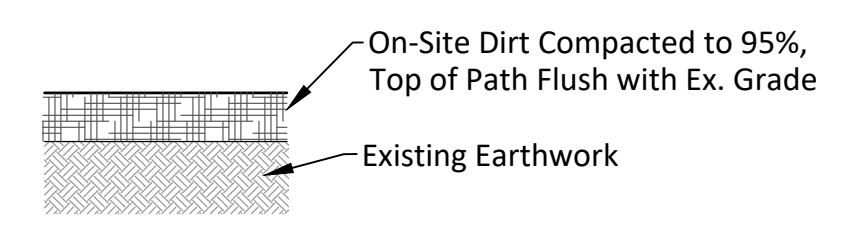

DIRT PATH SECTION

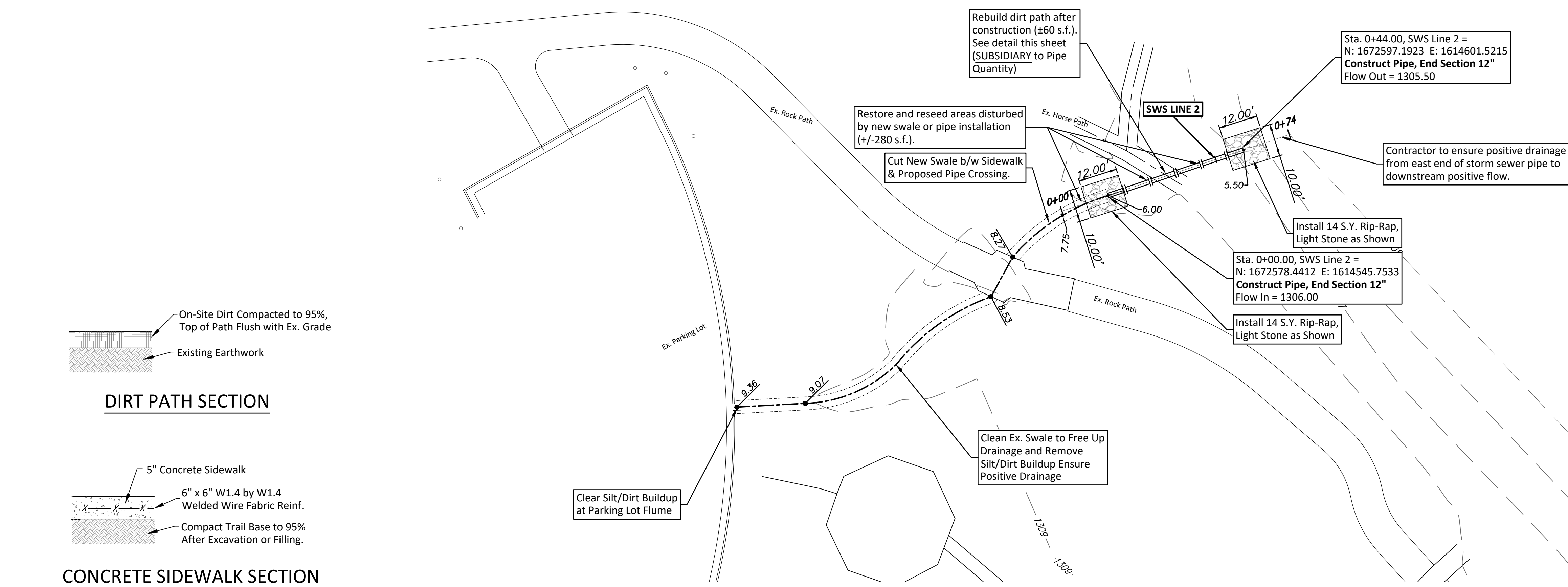
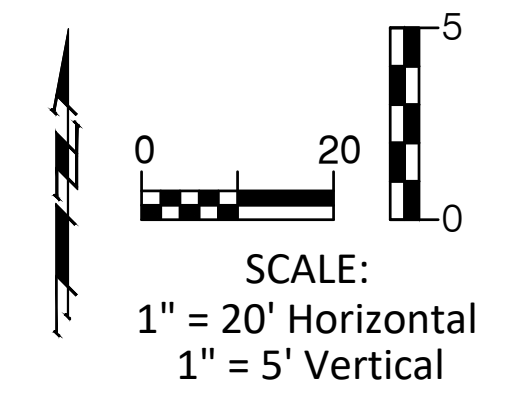
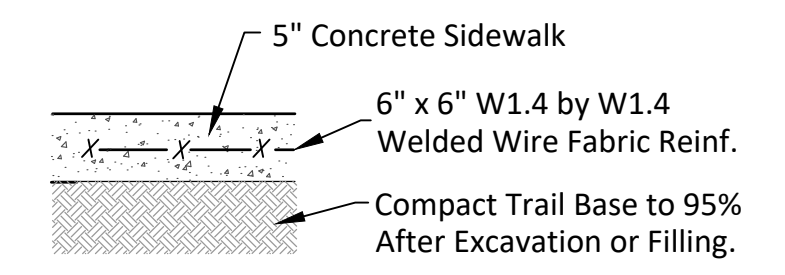

CONCRETE SIDEWALK SECTION

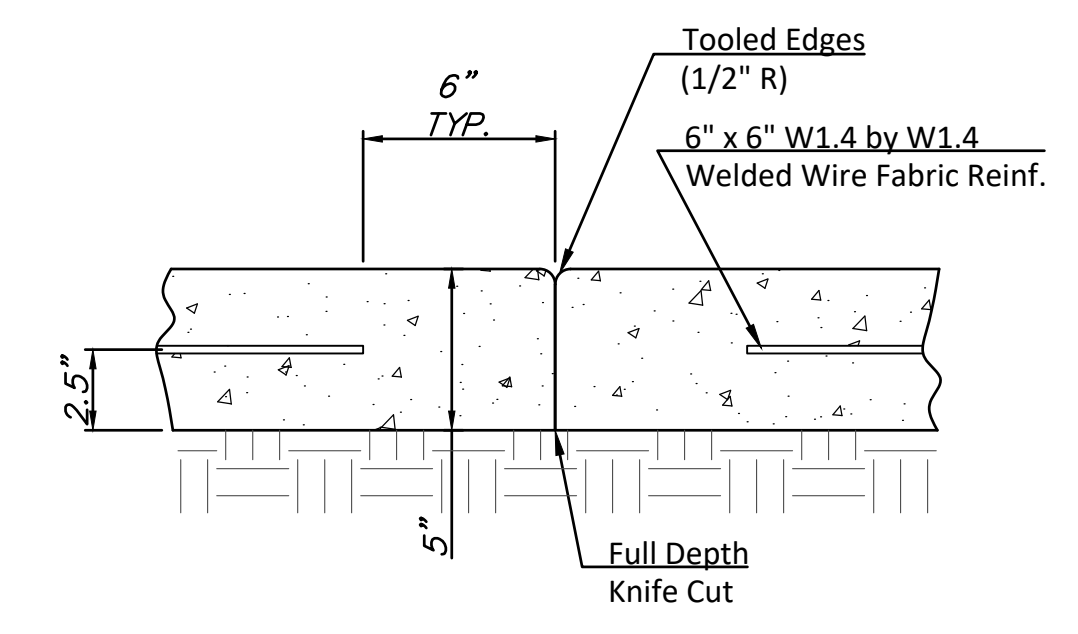

TYPICAL CONTRACTION JOINT DETAIL

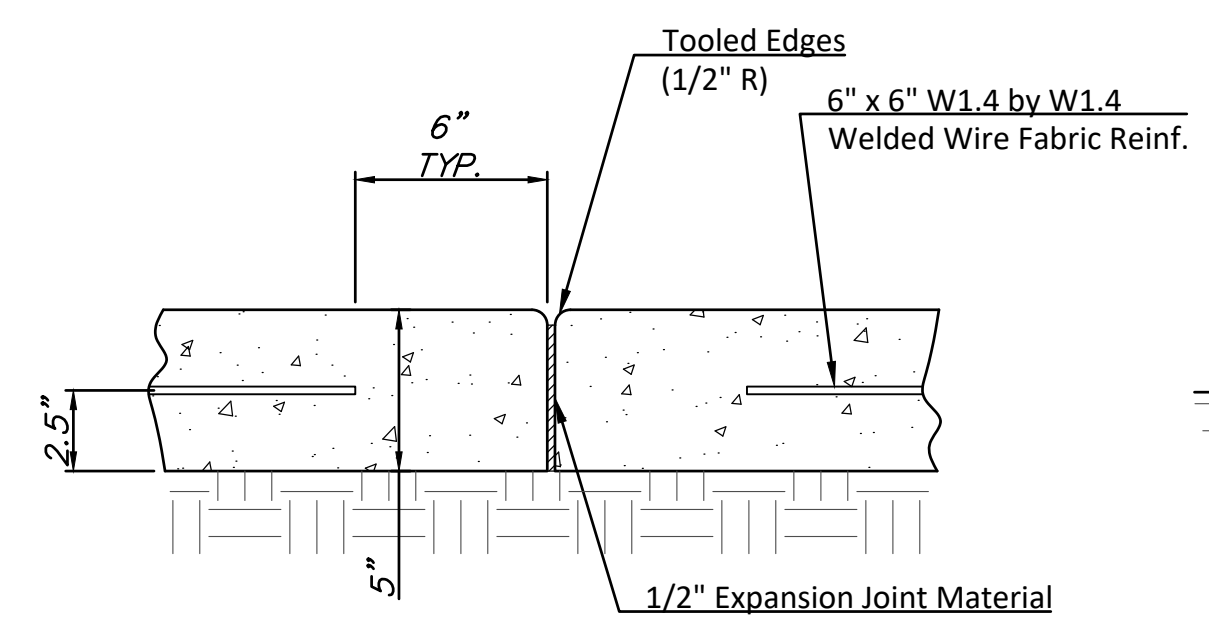

TYPICAL EXPANSION JOINT DETAIL

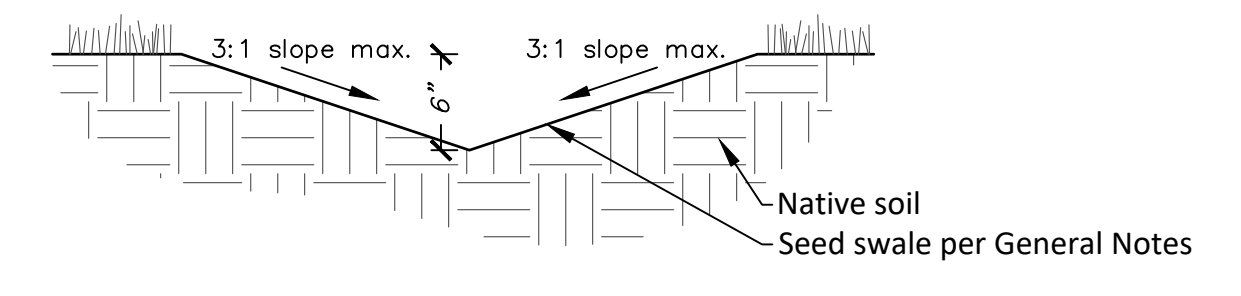

SWALE SECTION

