

SWALE SECTION

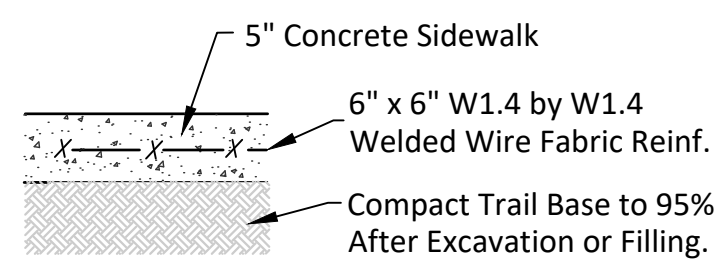

CONCRETE SIDEWALK SECTION

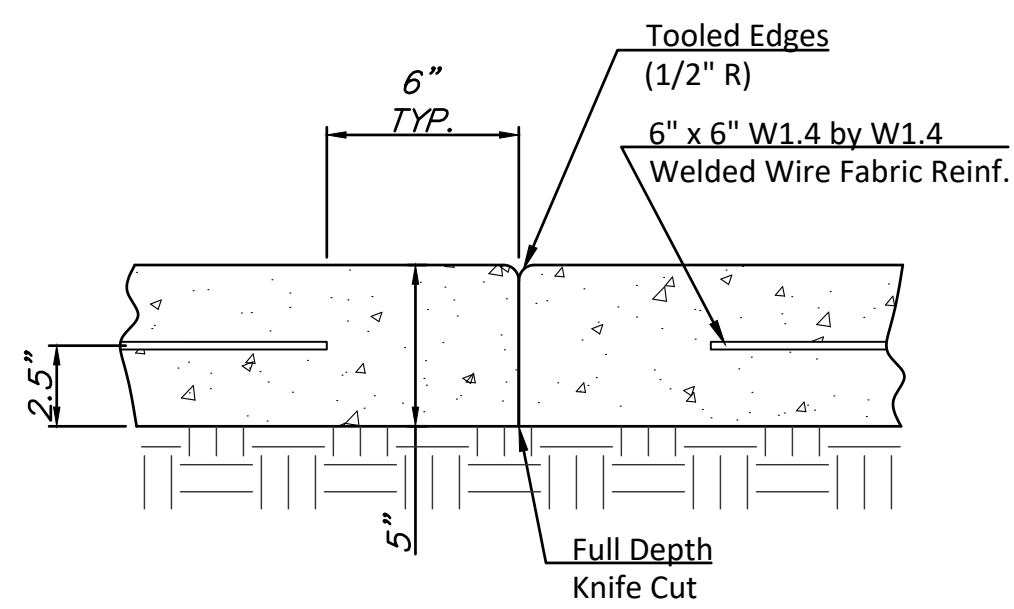

TYPICAL CONTRACTION JOINT DETAIL

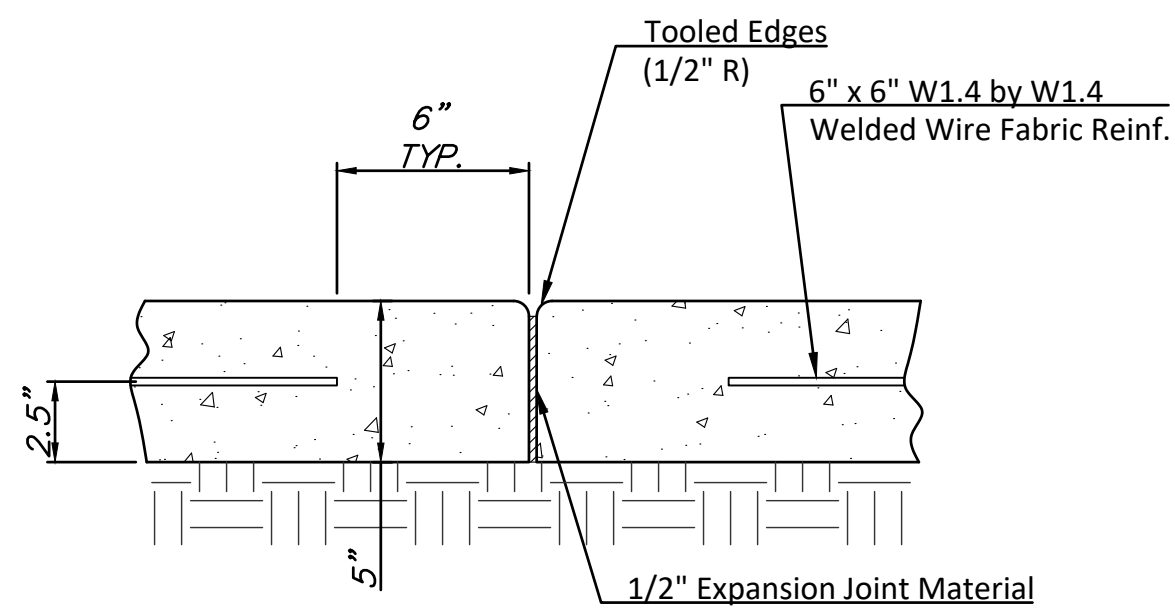

TYPICAL EXPANSION JOINT DETAIL

