

BENCHMARKS

BM#8 - Small Railroad Spike on South face of the Power Pole,
 Located on the 3rd New Pole West of Maize Road on the
 North Side of 29th Street.
 Elev. = 1350.91 MSL (163.51 City Datum)

FWA REGION NO.	STATE	PROJECT NO.	FISCAL YEAR	SHEET NO.	TOTAL SHEETS
7	KANSAS	87N-0348-01	2007	67	135

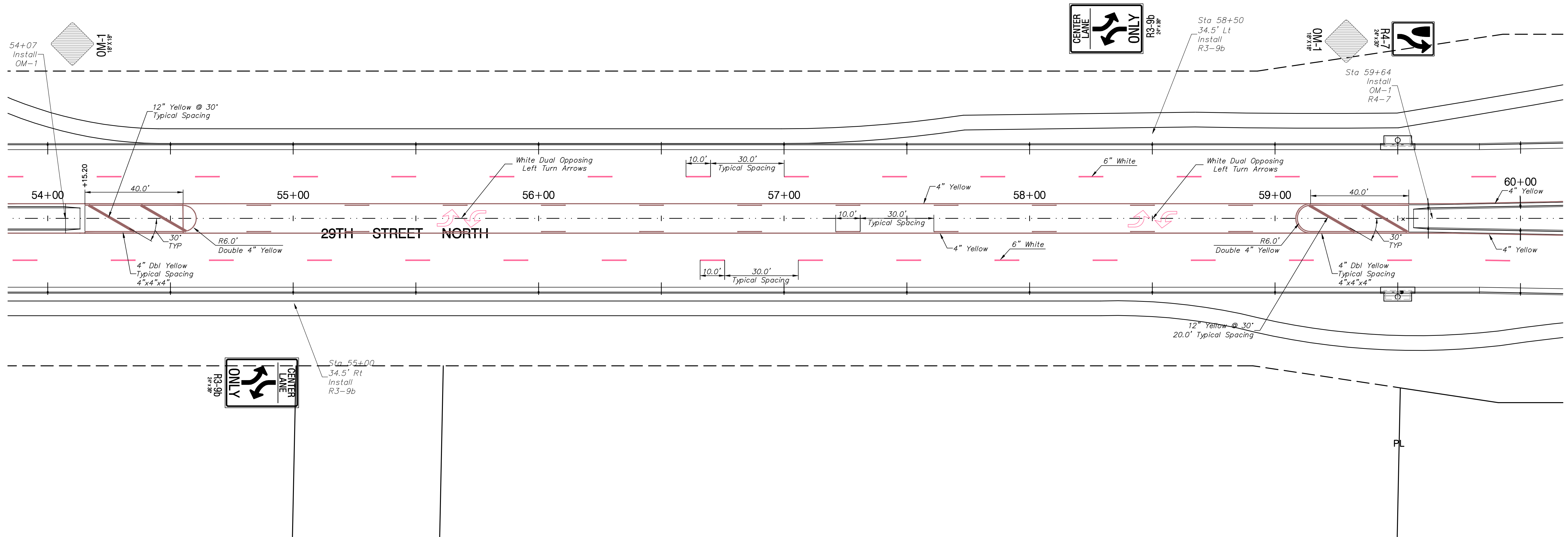
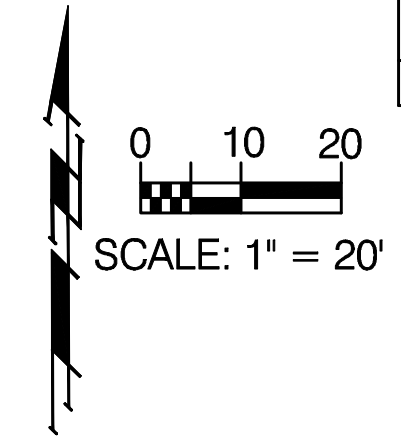

Drawing File: F:\eng\29th (Maize-119th)\(Pav10)
 Design: AZIERE
 Drawn: AZIERE
 Approved: JFB
 Scale: NOTED

Project No. 0403-E828 CAPITAL IMPROVEMENT PROJECT
29th Street Marking and Signing Plan
 Sta. 54+00 to Sta. 60+00
29th Street Paving Project - Maize Road to 119th Street

Baughman Company, P.A.
 315 Ella St. Wichita, KS 67211 P 316-262-7271 F 316-262-0149
 ENGINEERING | SURVEYING | PLANNING | LANDSCAPE ARCHITECTURE

March, 2007
 SHEET
67
 OF
135