

FHWA REGION NO.	STATE	PROJECT NO.	FISCAL YEAR	SHEET NO.	TOTAL SHEETS
7	KANSAS	87TE0074-01	1996	12	21

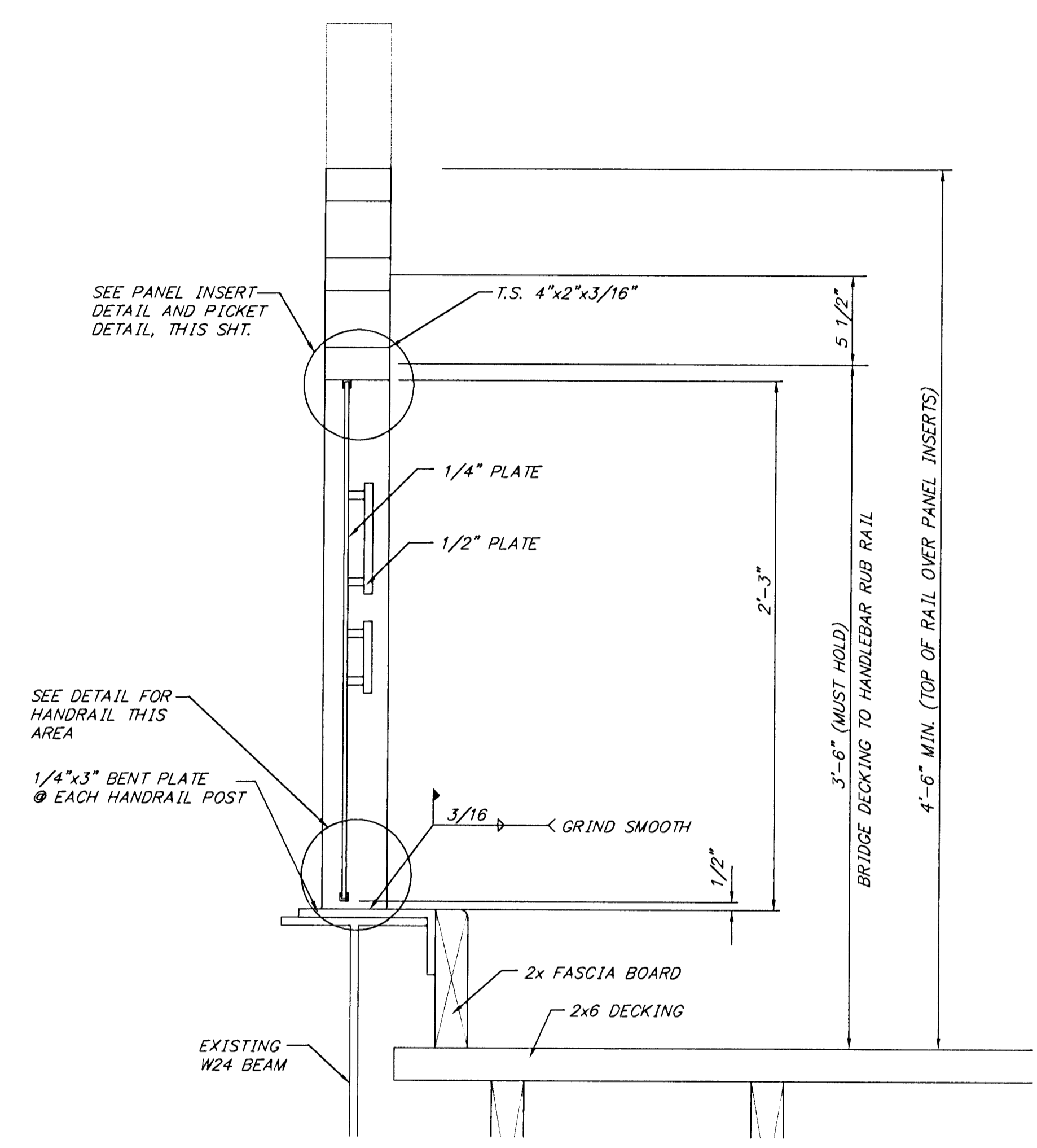

HANDRAIL SECTION  
NO SCALE

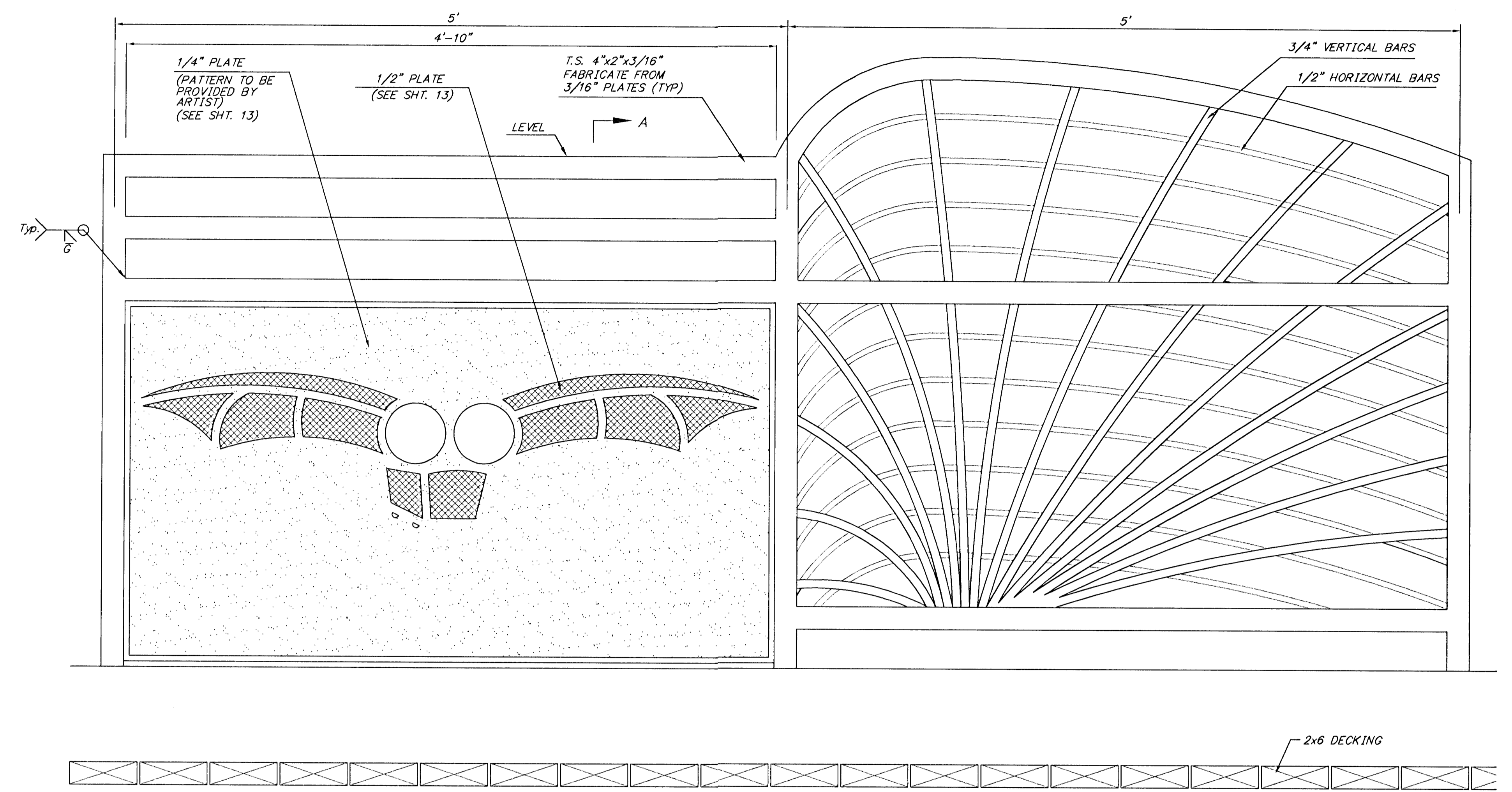

HANDRAIL ELEVATION  
NO SCALE

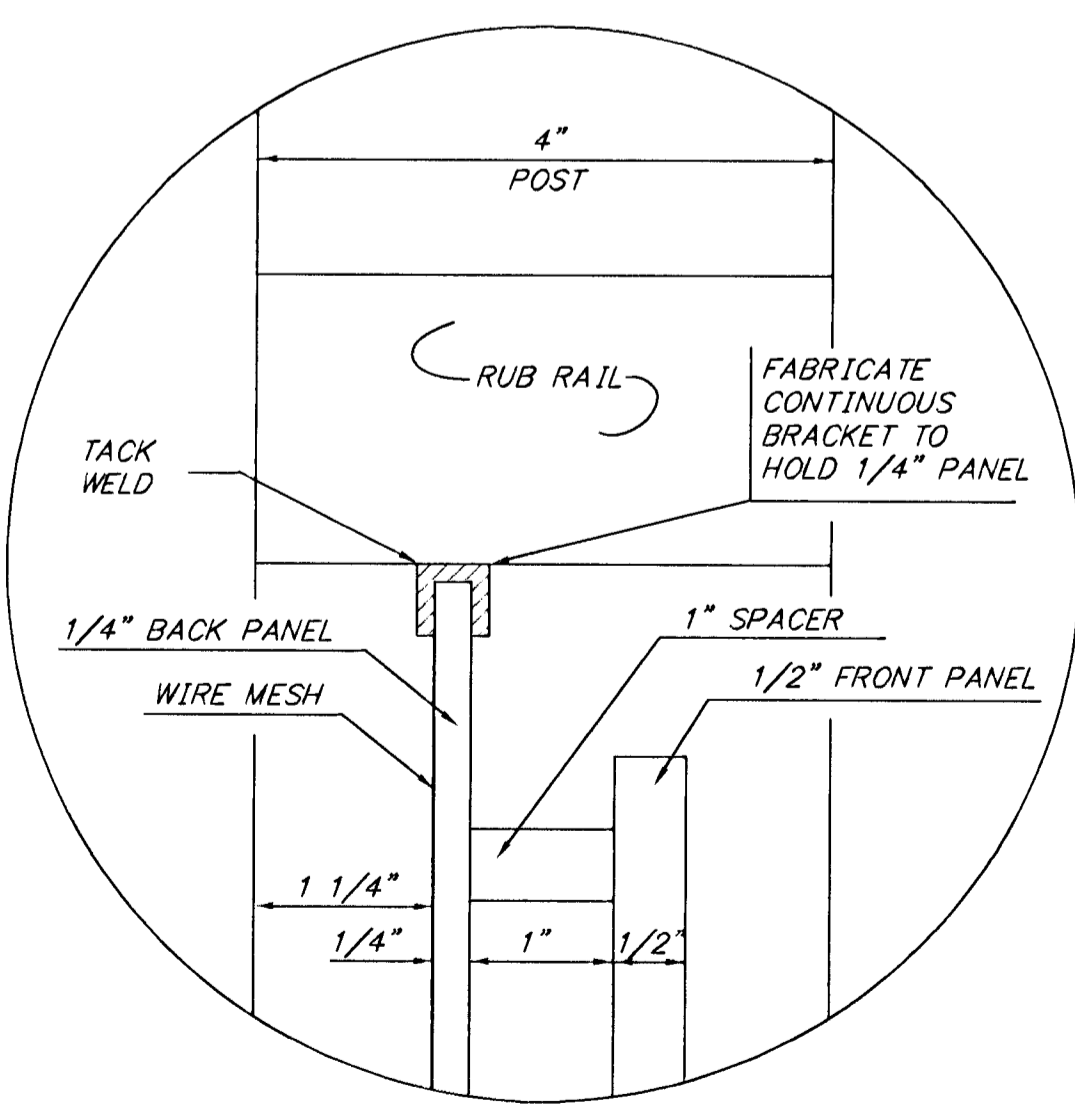

PANEL INSERT DETAIL  
NO SCALE

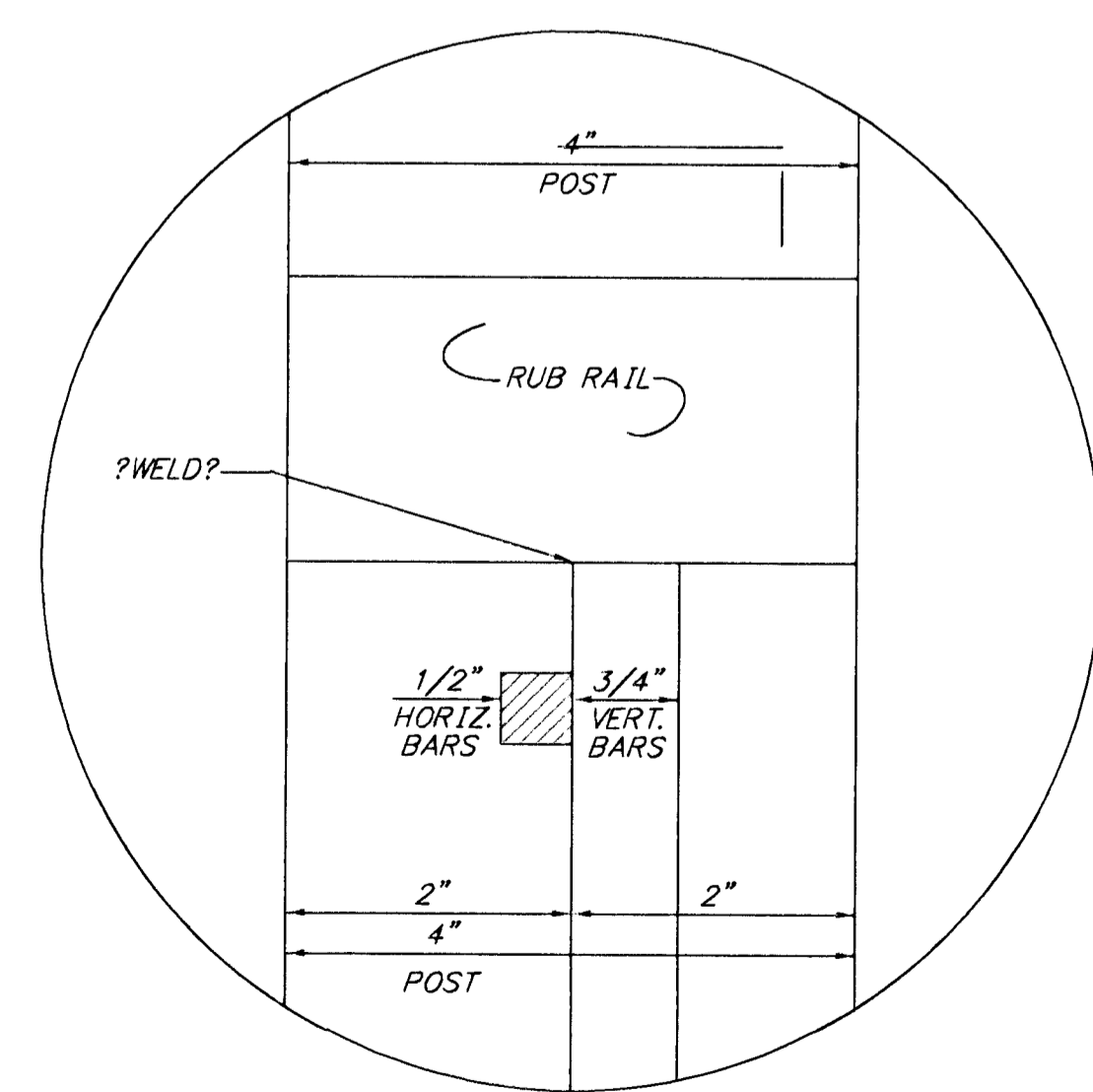

PICKET DETAIL  
NO SCALE

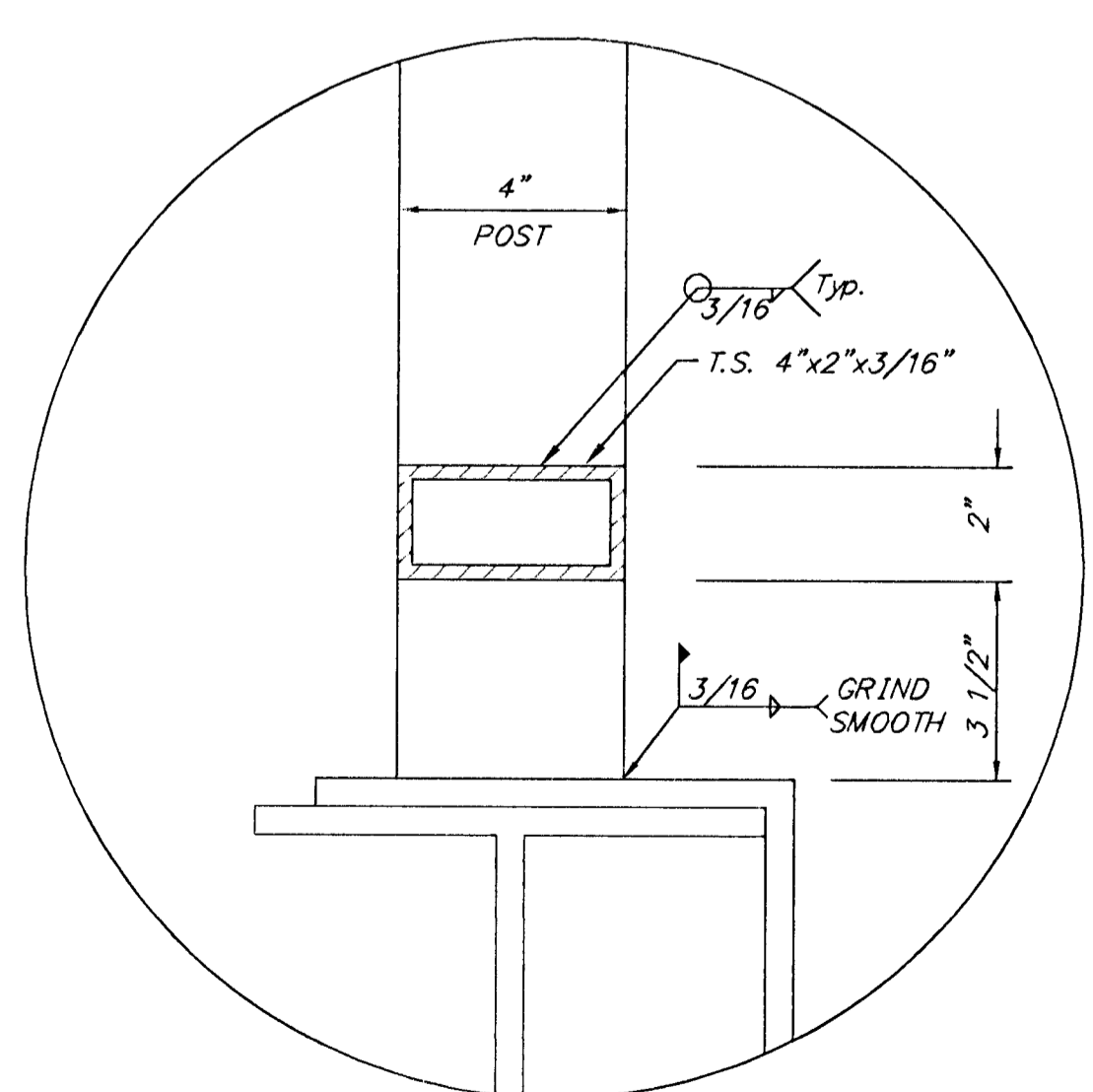

BOTTOM HANDRAIL DETAIL  
NO SCALE

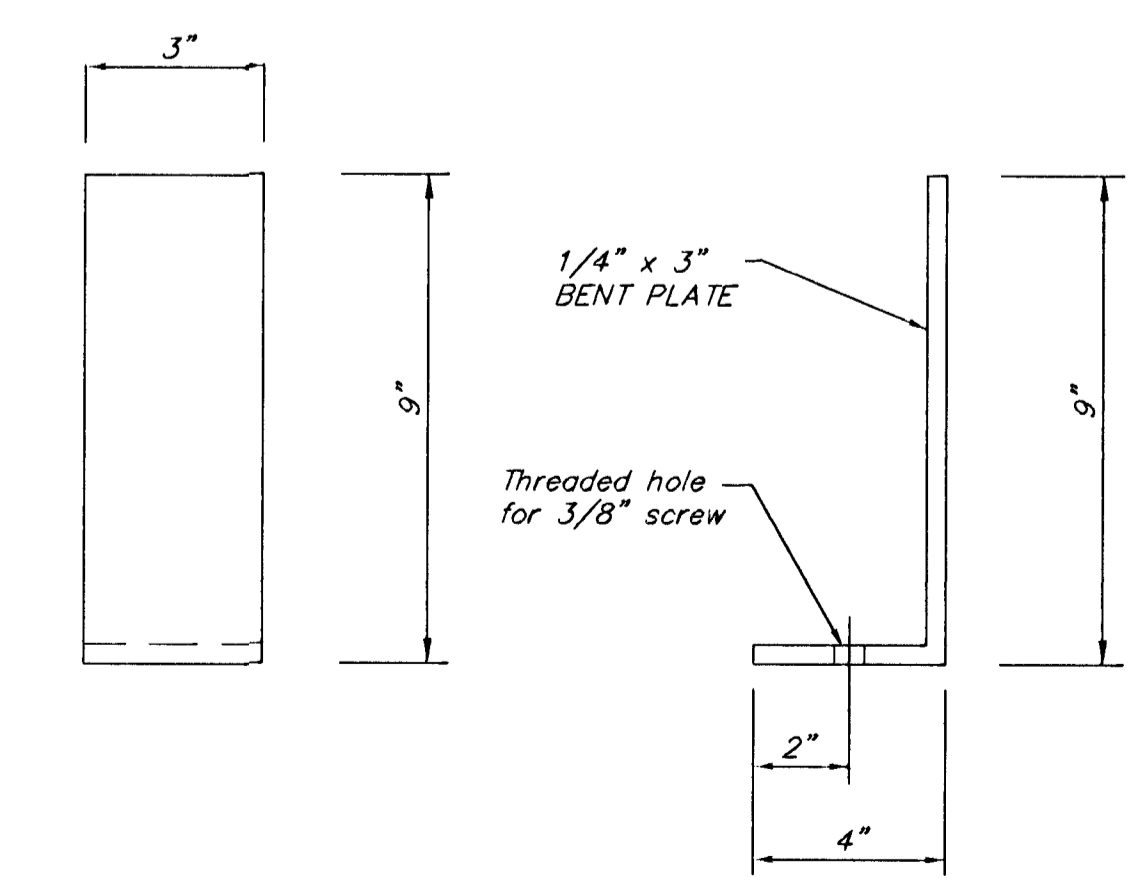

HANDRAIL BASE PLATE  
NO SCALE

GYPSUM CREEK BICYCLE PATH  
**BRIDGE DETAILS**  
HANDRAIL DETAILS

**BAUGHMAN COMPANY P. A.**  
ENGINEERING, SURVEYING, & PLANNING  
316-282-7271 • 315 ELLIS • WICHITA, KANSAS 67211

PROJECT NUMBER  
**472-78-245-82854-000-001**

DESIGN BAM	DRAWN BAM	APPROVED	DATE 4/96	SCALE NONE
---------------	--------------	----------	--------------	---------------

SHEET **12** OF **21**

95-10-E-148  
GYP21BR1002Z