

PLAN

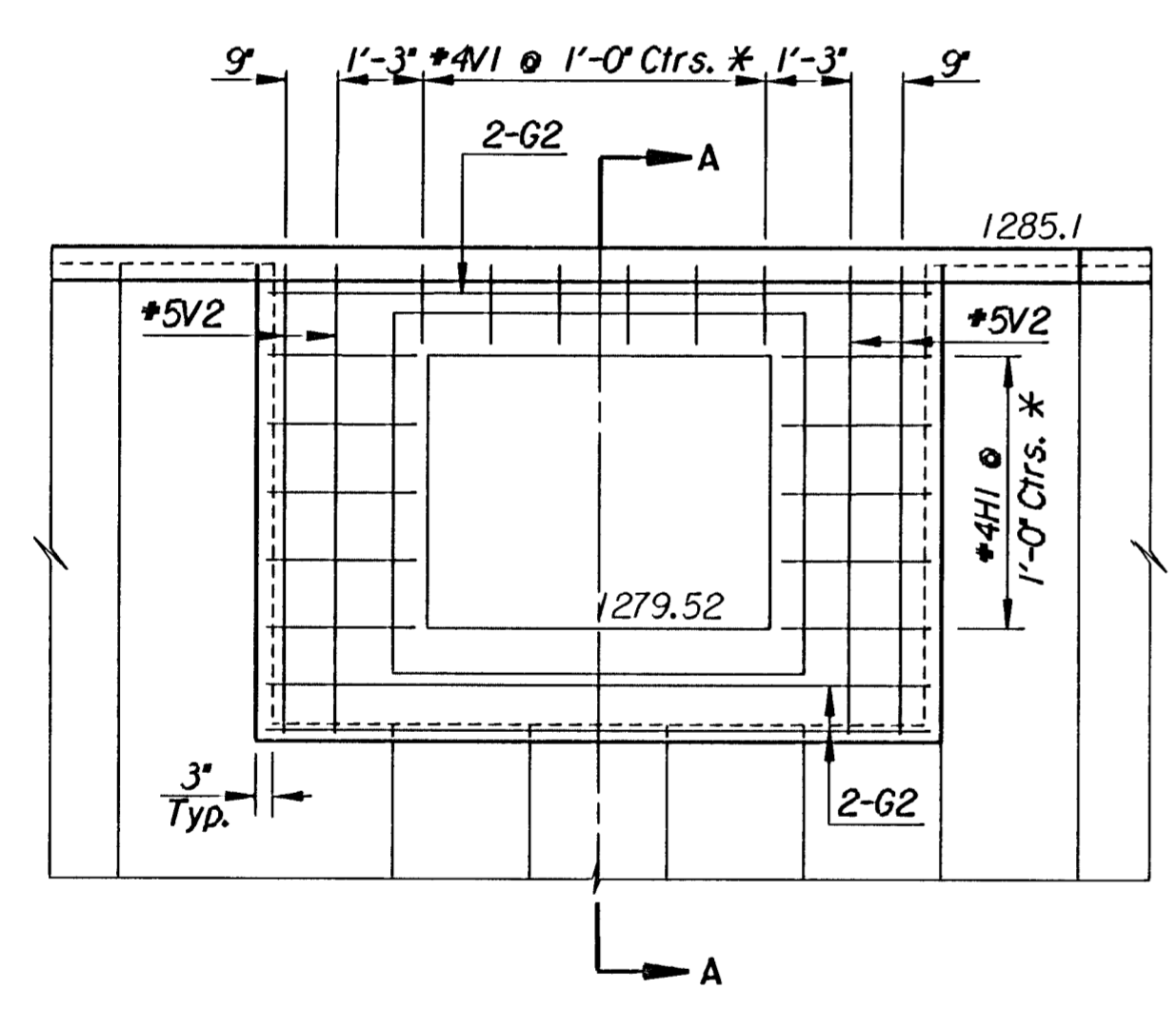

ELEVATION

* Dowel & Grout 4"

SWS LINE A-125

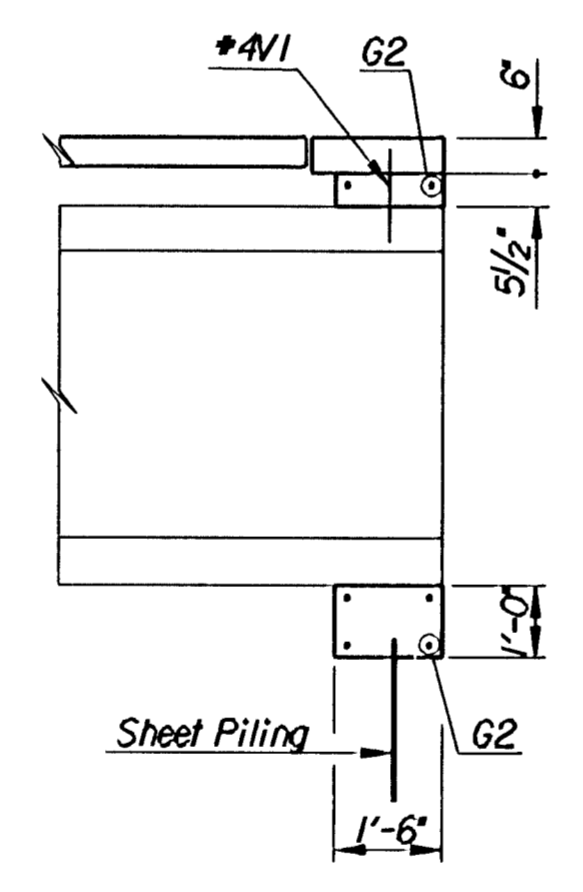

SECTION A-A

All reinforcing clearance to be 2".
See Sh. No. C9 for Reinforcing & Concrete Quantities & Notes.

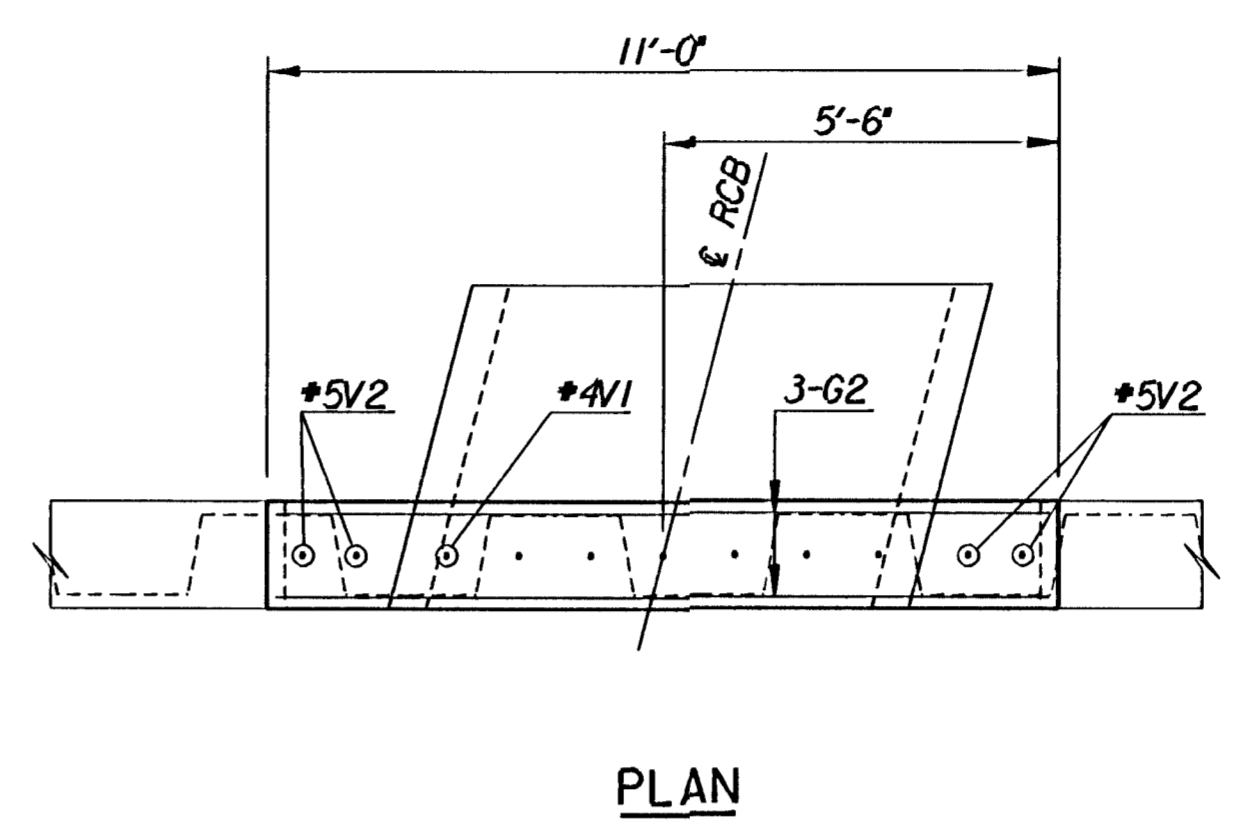

PLAN

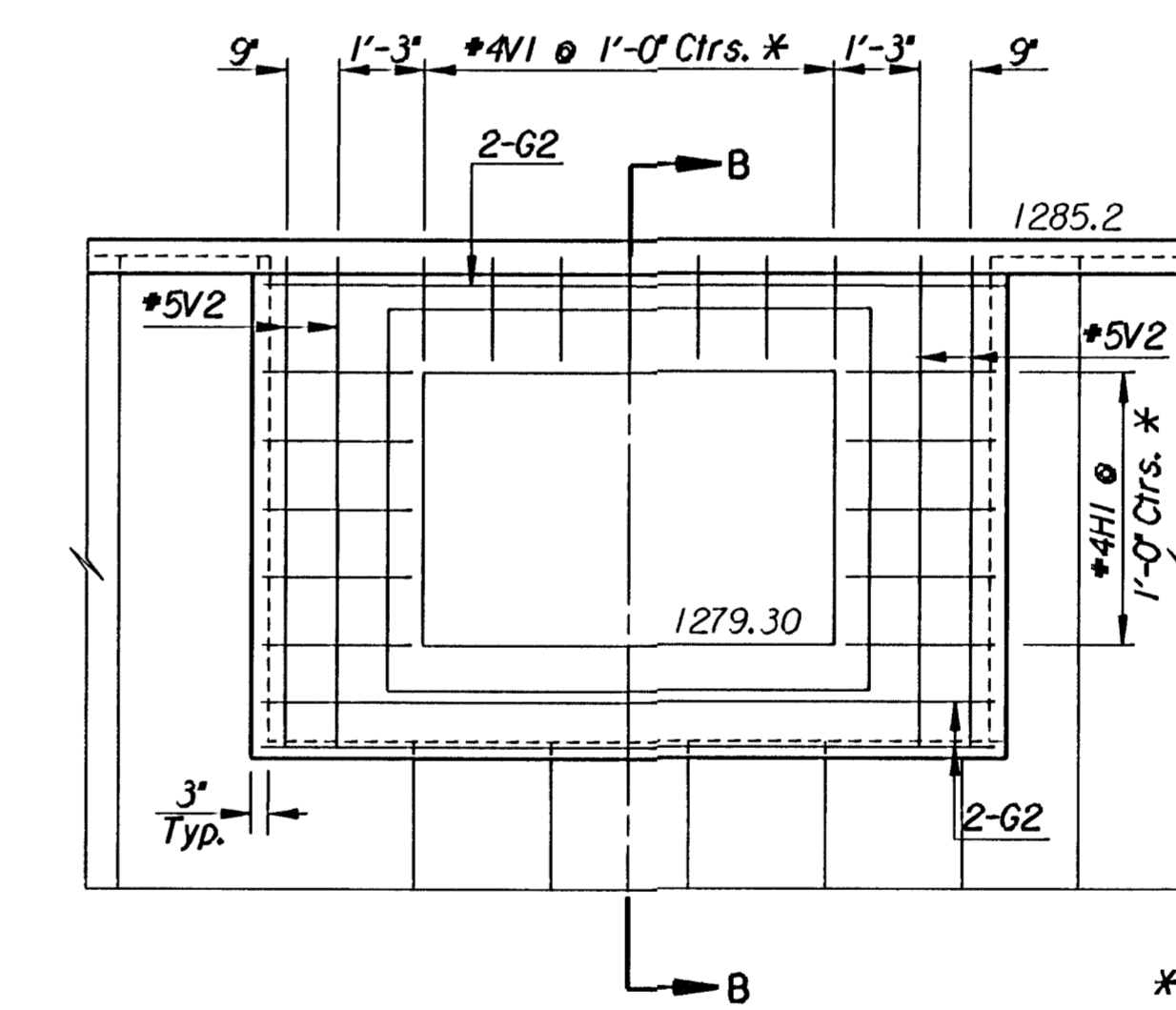

ELEVATION

* Dowel & Grout 4"

SWS LINE B-1

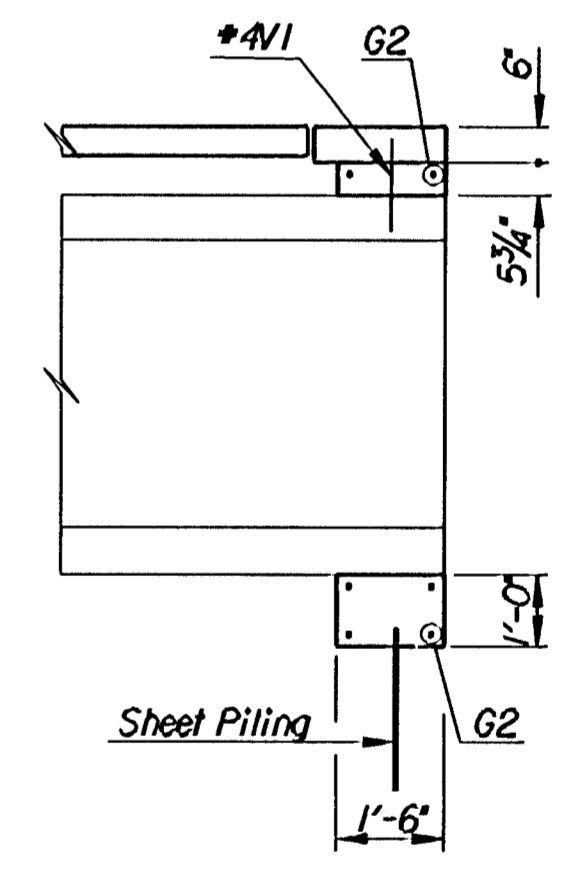

SECTION B-B

All reinforcing clearance to be 2".
See Sh. No. C7 for Reinforcing & Concrete Quantities & Notes.

I:\1995\95088\douglas\collar.dgn
Drawn by: wil
Plotted by: wil 8-26-97

No.	Revisions	By	Date
CITY OF WICHITA, KANSAS MICHAEL E. LINDEBAK, P.E.-CITY ENGINEER DOUGLAS AVENUE BRIDGE OVER ARKANSAS RIVER HEADWALL DETAILS CITY OF WICHITA PROJECT NO. 472-82721 PROFESSIONAL ENGINEERING CONSULTANTS, P.A. ENGINEERS WICHITA, KANSAS			
Designed by	R.W.A.	Checked by	R.A.S.
Drawn by	W.L.L.	Date	Sept. 1997 Job No. 95088-4