

Combined Curb & Gutter (6")

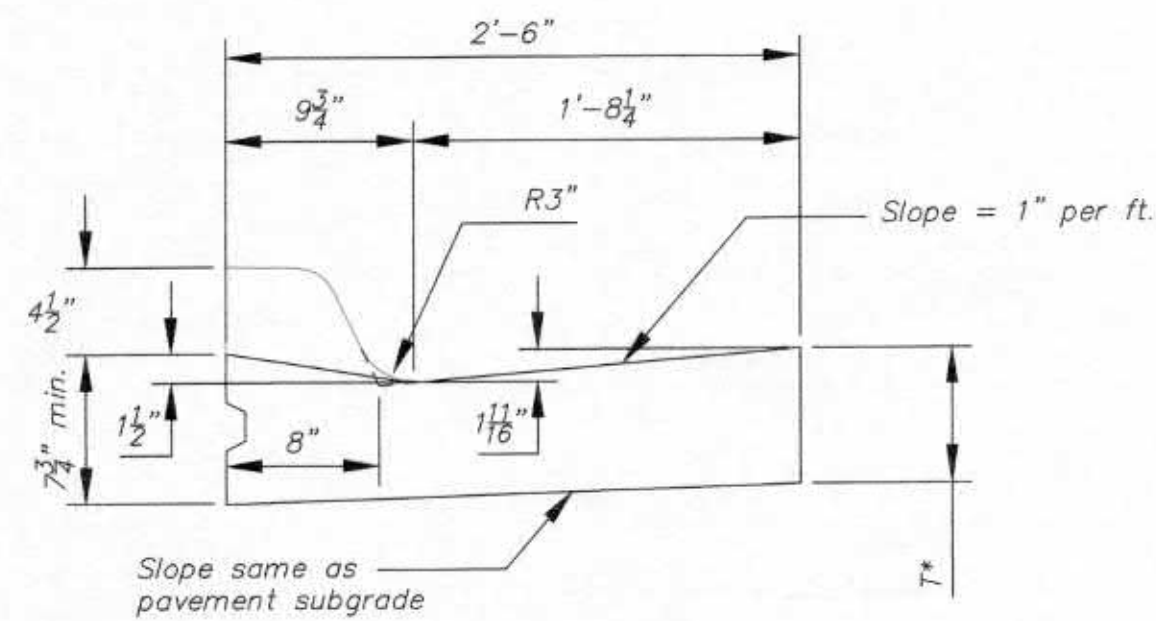

Combined Curb & Gutter (1 1/2")

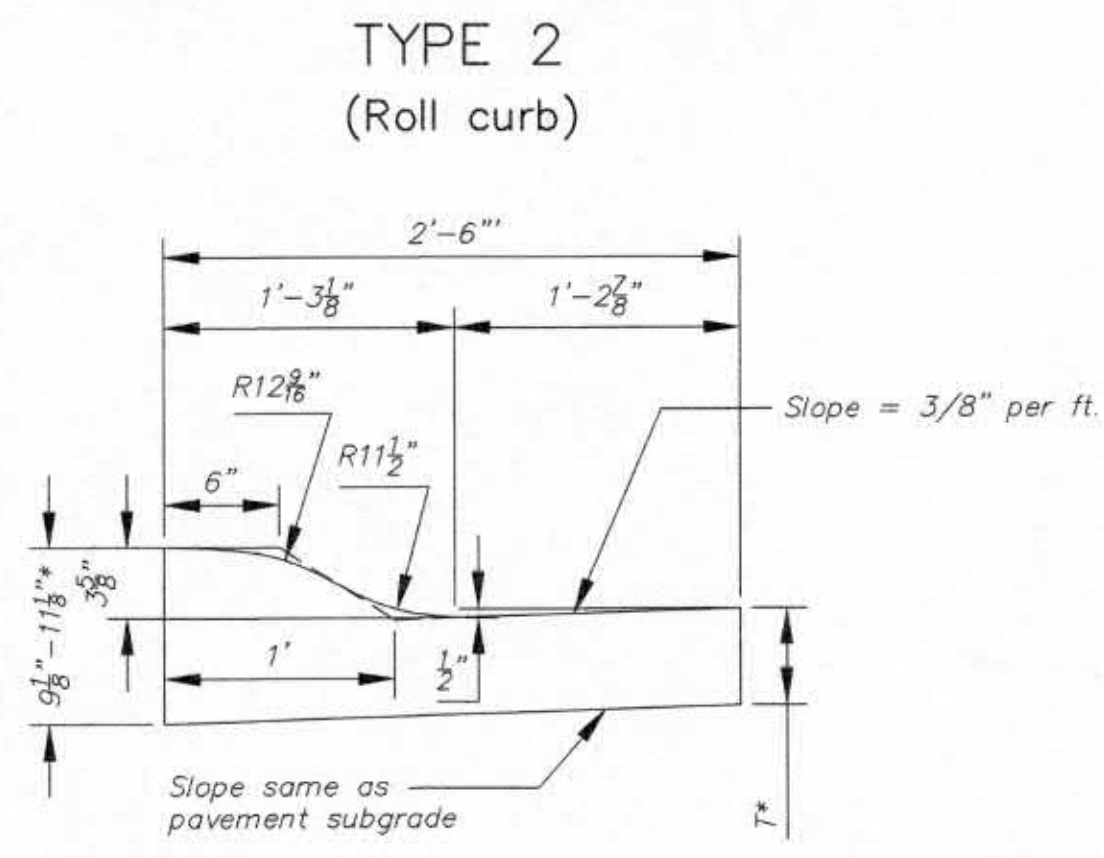

Combined Curb & Gutter (3 5/8")

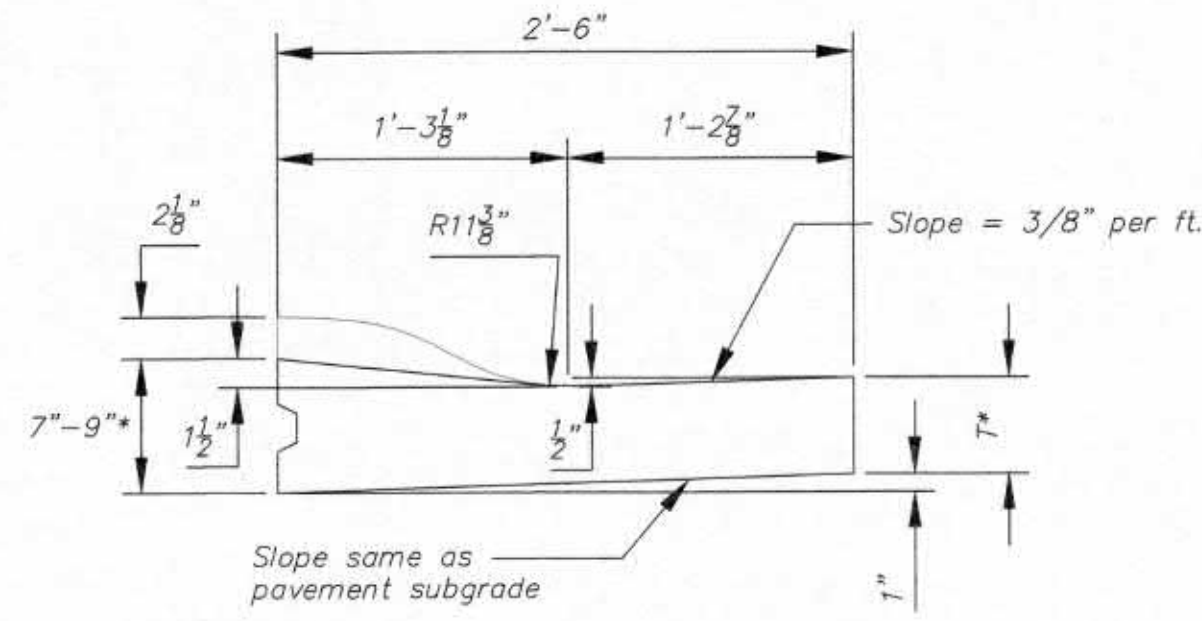

Combined Curb & Gutter (1 1/2")

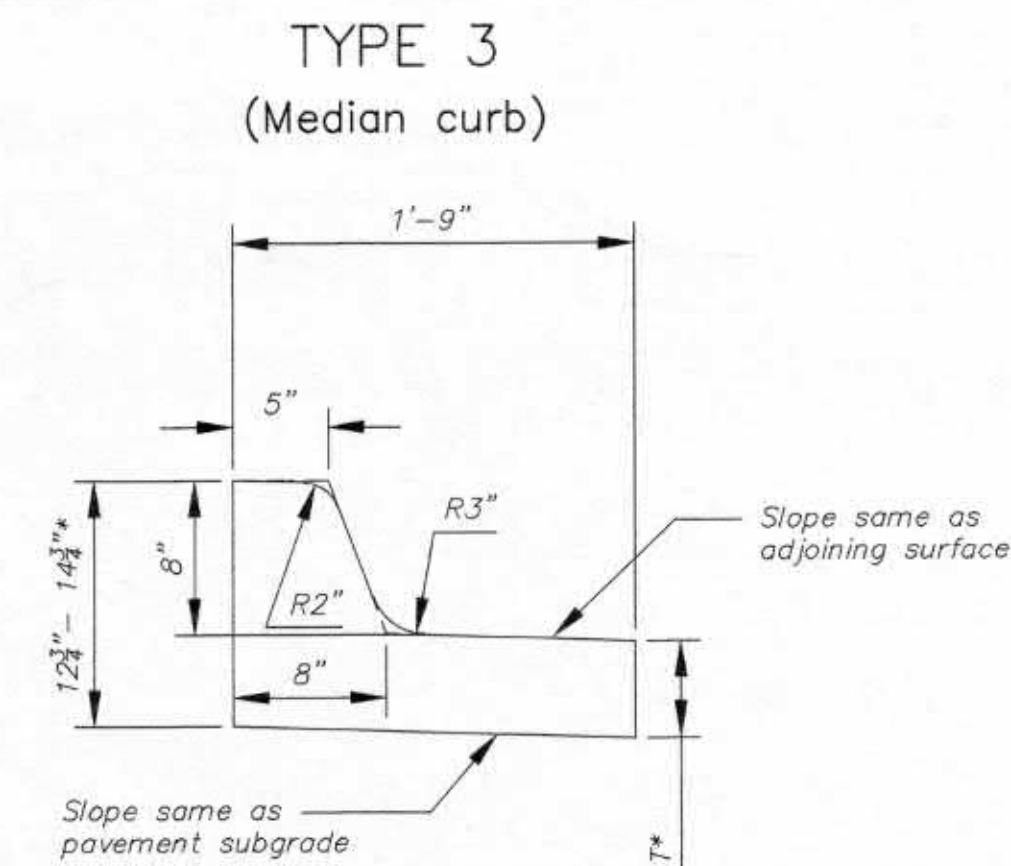

Combined Curb & Gutter (8")

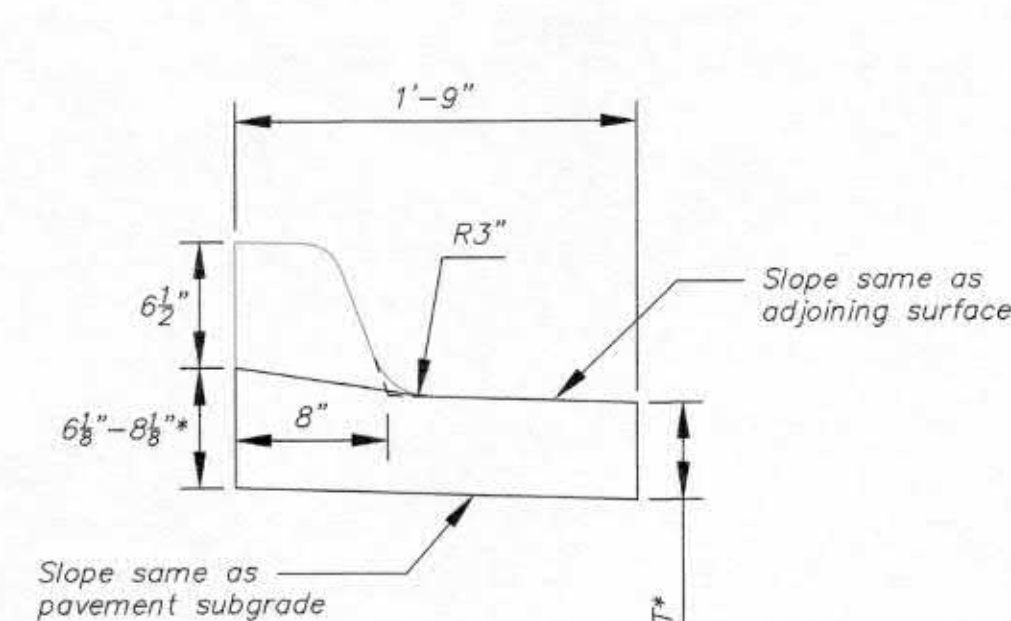

Combined Curb & Gutter (1 1/2")

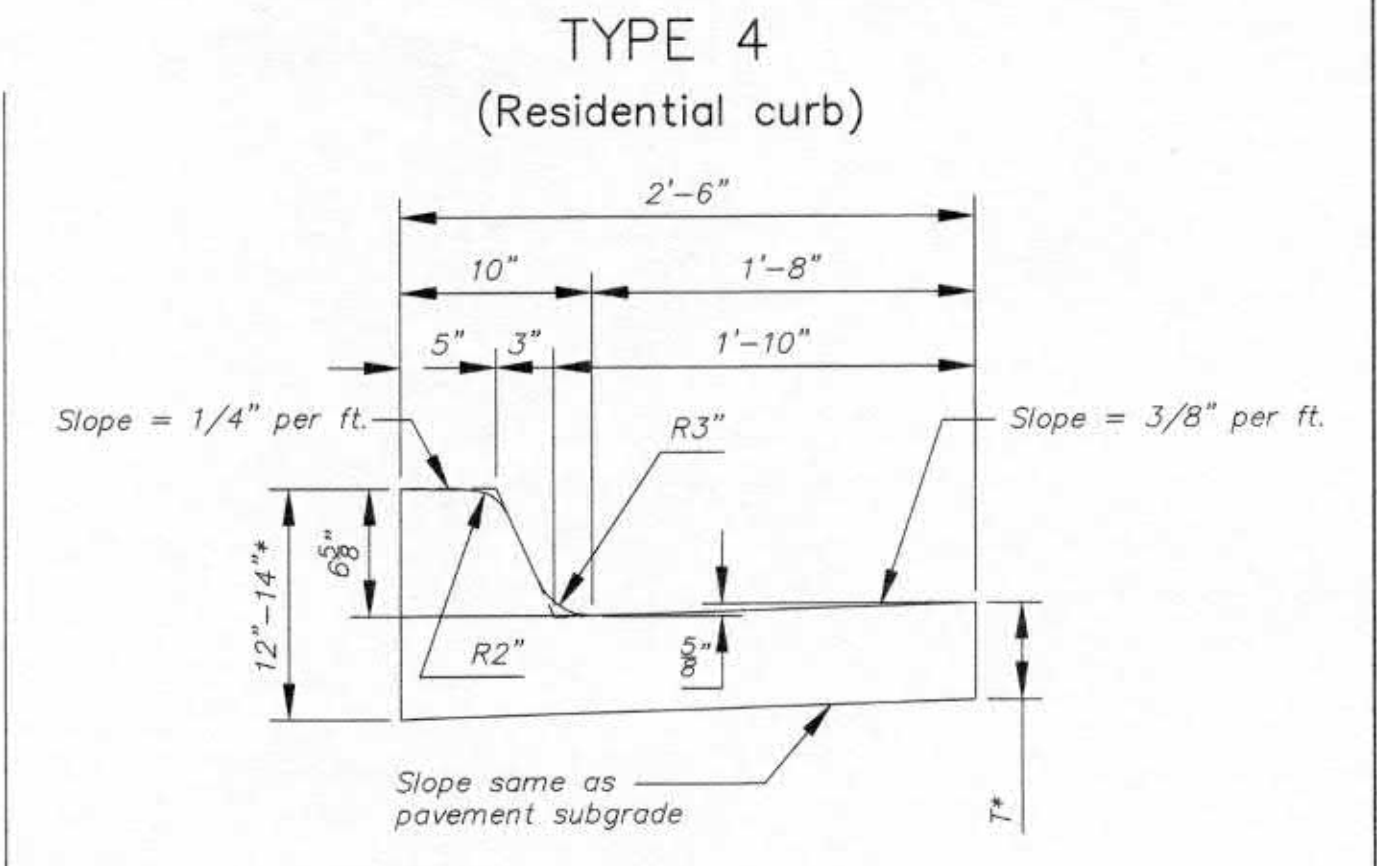

Combined Curb & Gutter (6 5/8")

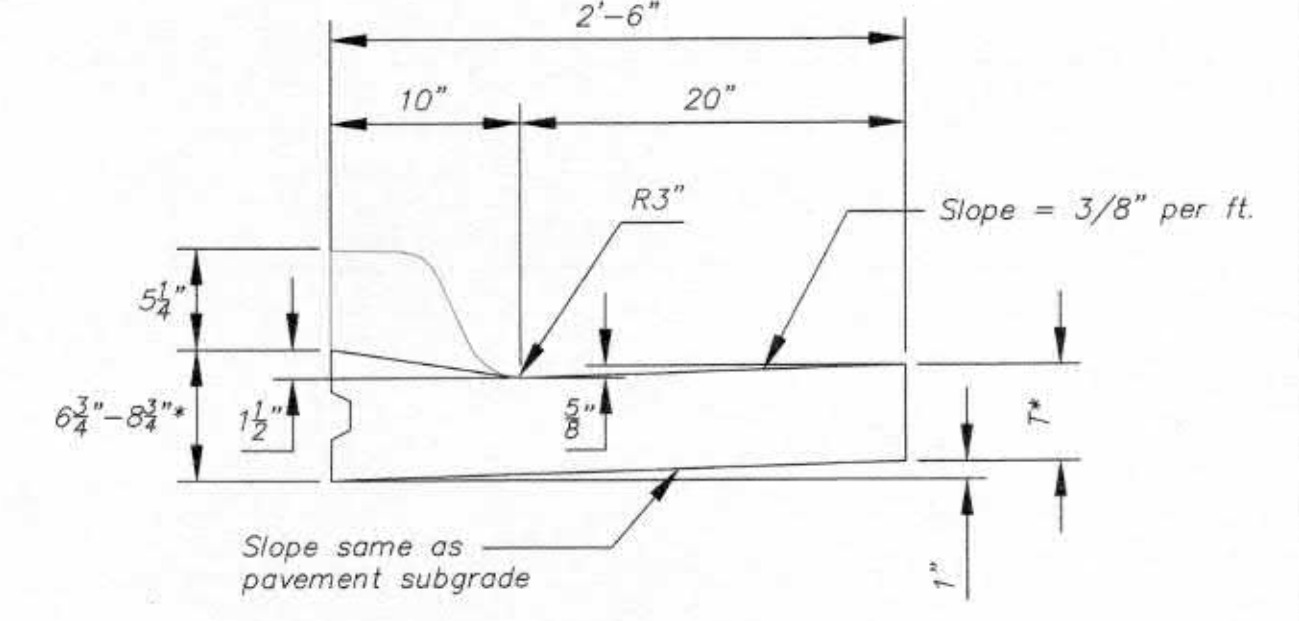

Combined Curb & Gutter (1 1/2")

T* = Thickness of curb to adjust with pavement thickness

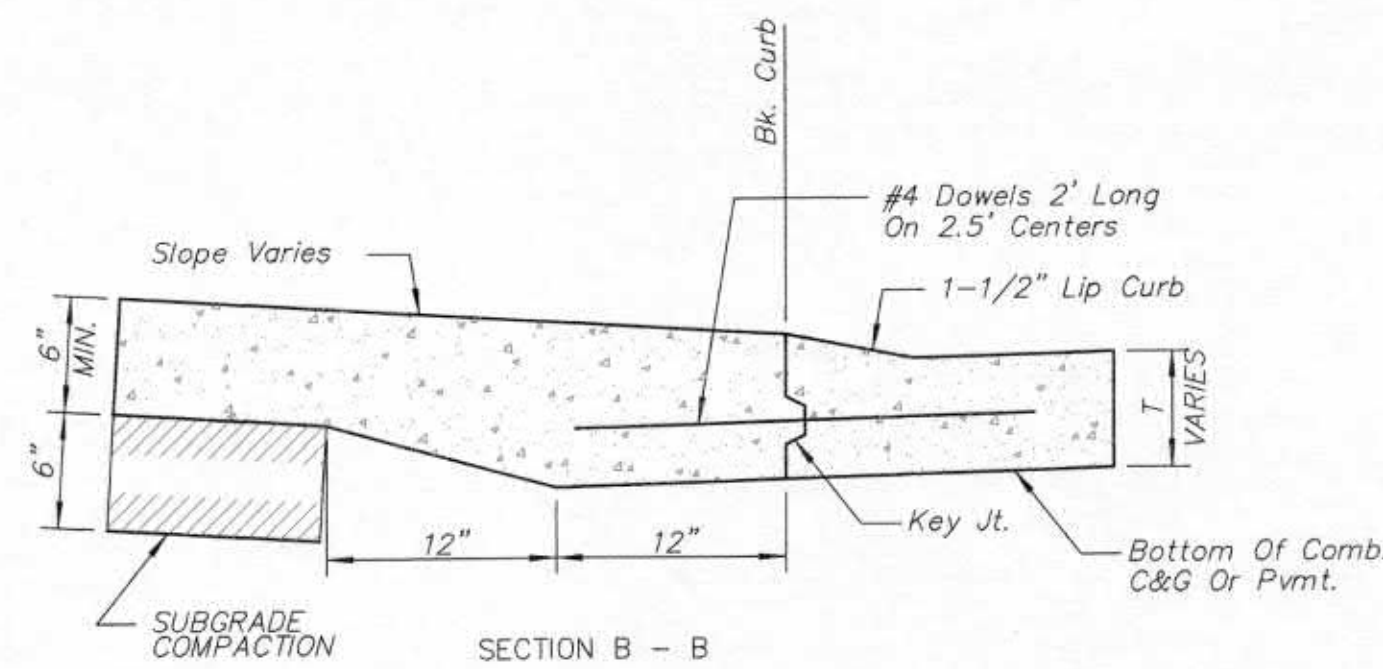

BACK OF CURB DETAIL

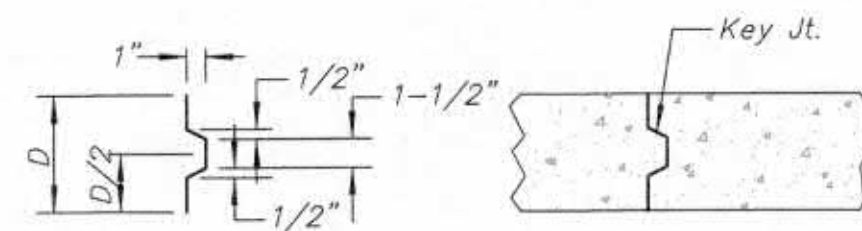

ALT. LONGITUDINAL CONSTRUCTION JOINT

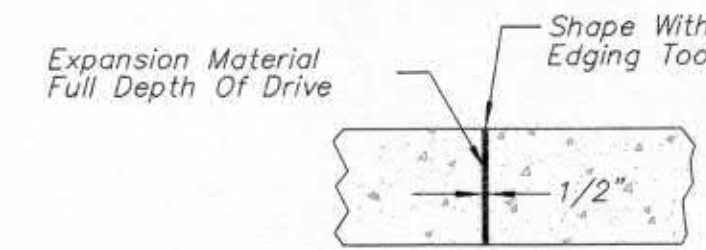

EXPANSION JOINT (E.J.)

GENERAL NOTES

- Expansion (isolation) joints shall be constructed a maximum of 300' apart and at all PIs, PCs, cul-de-sac quadrants, and ends of returns.
- Contraction joints shall be constructed a minimum of 12' apart.
- Joint sealer shall be required at all joints on arterial and industrial streets and at intersections on residential streets.

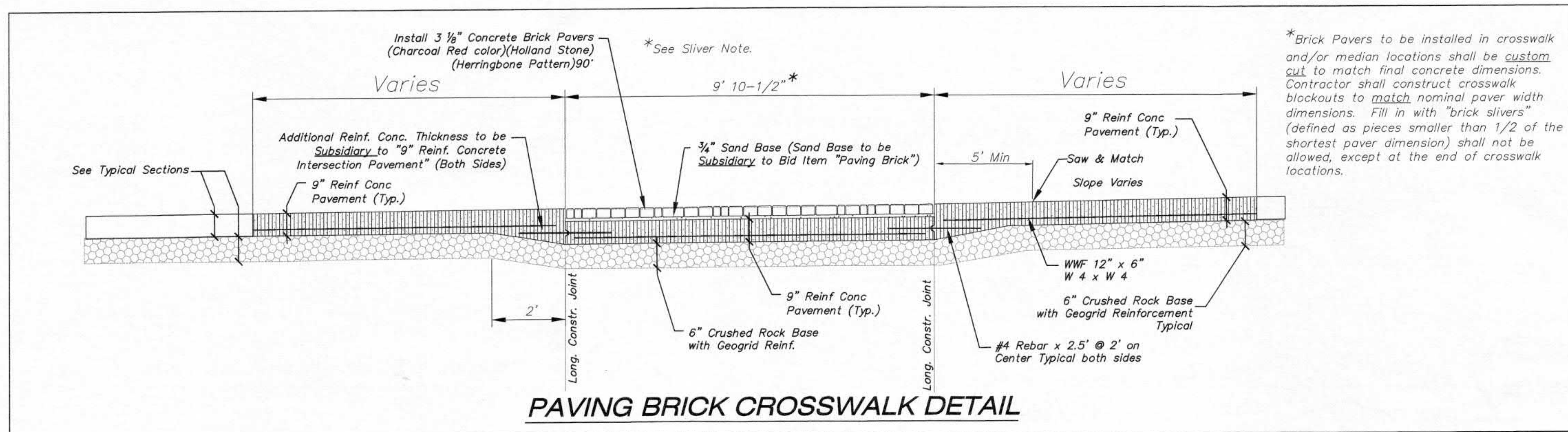

PAVING BRICK CROSSWALK DETAIL



| | | |
|--|------------|-------------------------|
| CITY OF WICHITA | | |
| PUBLIC WORKS & UTILITIES ENGINEERING DIVISION | | |
| CURB & GUTTER & PAVING BRICK CROSSWALK DETAILS | | |
| CITY ENGINEER GARY JANZEN, P.E. | | |
| PROJECT NUMBER | OCA NUMBER | DATE |
| CITY ENGINEER'S OFFICE CITY HALL - SEVENTH FLOOR 455 NORTH MAIN STREET WICHITA, KANSAS 67202-1620 (316) 268-4501 | | SHEET 8 of 24 |

REVISED: OCTOBER 1975