

DRAINAGE DATA TABLE

BASIN	English (U.S.) $Q = *CIA$												Metric (S.I.)					Storm Sewer		
	AREA (acre)	T_c (min)	I_s (in)	I_{100} (in)	Q_s (cfs)	Q_{100} (cfs)	CUM. AREA (acre)	$T_{c_{95}}$ (min)	I_s (in)	I_{100} (in)	Q_s (cfs)	Q_{100} (cfs)	AREA (hectare)	Q_s (cms)	Q_{100} (cms)	CUM. AREA (hectare)	Q_s (cms)	Q_{100} (cms)	INLET (length)	PIPE (diameter)
A	1.28	15	4.56	7.37	4.7	7.6	4.18	15	4.56	7.37	15.3	24.7	0.52	0.13	0.22	1.70	0.43	0.70	1525 mm	900 mm RCP
B	1.28	15	4.56	7.37	4.7	7.6	2.90	15	4.56	7.37	10.6	17.1	0.52	0.13	0.22	1.18	0.30	0.48	1525 mm	750 mm RCP
C	0.81	15	4.56	7.37	3.0	4.8	1.62	15	4.56	7.37	5.9	9.6	0.33	0.08	0.14	0.66	0.17	0.27	1525 mm	750 mm RCP
D	0.81	15	4.56	7.37	3.0	4.8	0.81	15	4.56	7.37	3.0	4.8	0.33	0.08	0.14	0.33	0.08	0.14	1525 mm	600 mm RCP
E	0.73	15	4.56	7.37	2.7	4.3	1.46	15	4.56	7.37	5.4	8.6	0.30	0.08	0.12	0.60	0.16	0.24	1525 mm	750 mm RCP
F	0.73	15	4.56	7.37	2.7	4.3	0.73	15	4.56	7.37	2.7	4.3	0.30	0.08	0.12	0.30	0.08	0.12	1525 mm	600 mm RCP
G	0.66	15	4.56	7.37	2.4	3.9	1.32	15	4.56	7.37	4.8	7.8	0.27	0.07	0.11	0.54	0.14	0.22	3050 mm	750 mm RCP
H	0.66	15	4.56	7.37	2.4	3.9	0.66	15	4.56	7.37	2.4	3.9	0.27	0.07	0.11	0.27	0.07	0.11	3050 mm	450 mm RCP
I	134	23	-	-	-	213	-	-	-	-	-	213	54.23	-	6.03	54.23	-	6.03	-	2440 mm x 1220 mm RCBC

* $C_s = 0.80$ $C_{100} = 0.80$

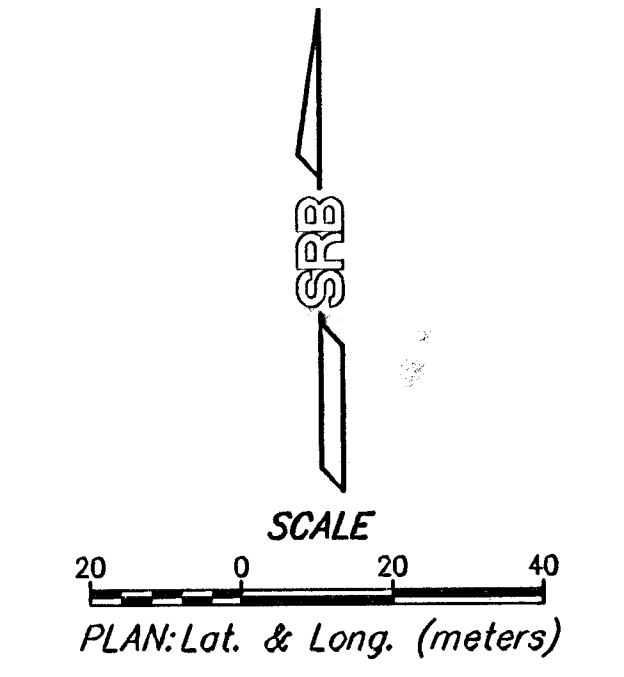

DATE	
BY	
REFERENCES NOTED	
REFERENCES CHECKED	

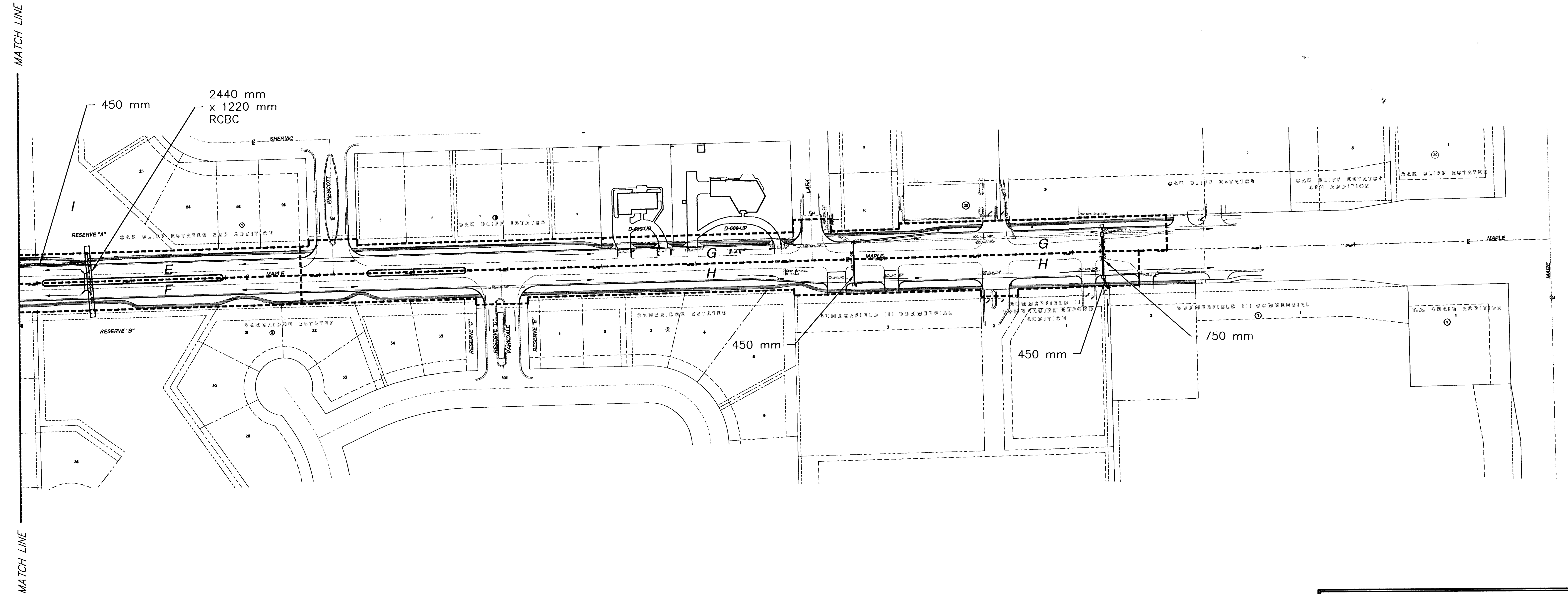

**MAPLE ST. IMPROVEMENTS - 119TH ST. W. TO MAIZE RD.
DRAINAGE MAP (Sta. 10+790.3 to Sta. 11+415.3)**

SRB		924 NORTH MAIN WICHITA, KANSAS 67203 http://www.srb.com/~sr		316-264-8008 FAX 264-4621 E-Mail: srb@sr.com	
SAVOY, RUGGLES & BOHM, P.A. ENGINEERING & SURVEYING					
PROJECT NUMBER 472-76-245-83053-000-000-001					
DRAWN Staff	DESIGN Staff	REVIEW Staff	DATE 6-28-99	UTILITY 1216T	SRB JOB 1216T

58
90