

BILL OF MATERIALS		
ITEMS	TOTAL	UNITS
COLD PLASTIC MARKING (CL. A)(6")	2995	LIN. FT.
COLD PLASTIC MARKING (CL. B)(18")	158	LIN. FT.
COLD PLASTIC MARKING (CL. B)(4")	2442	LIN. FT.
SIGNING		
R4-7 KEEP RIGHT	1	EACH
BREAKAWAY POST	9	LIN. FT.

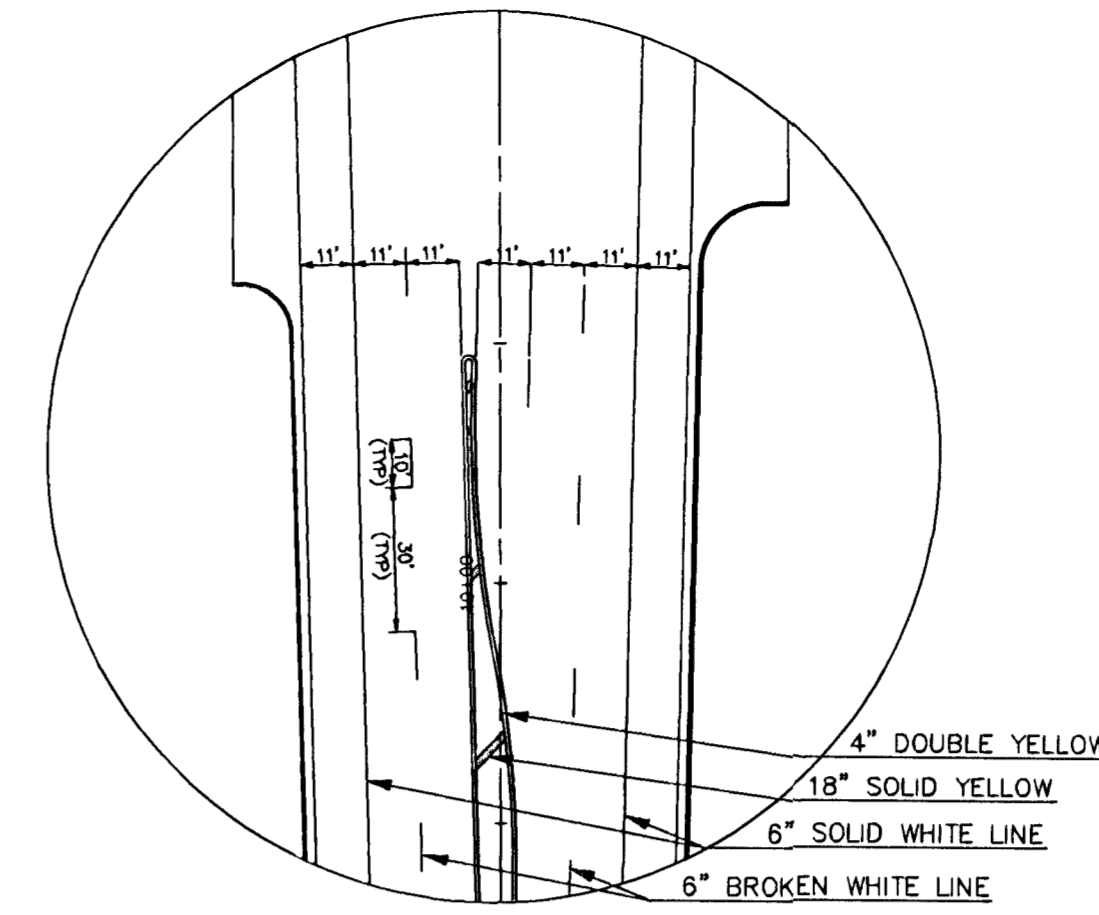

DETAIL FOR STA. 7+00 THRU 15+00

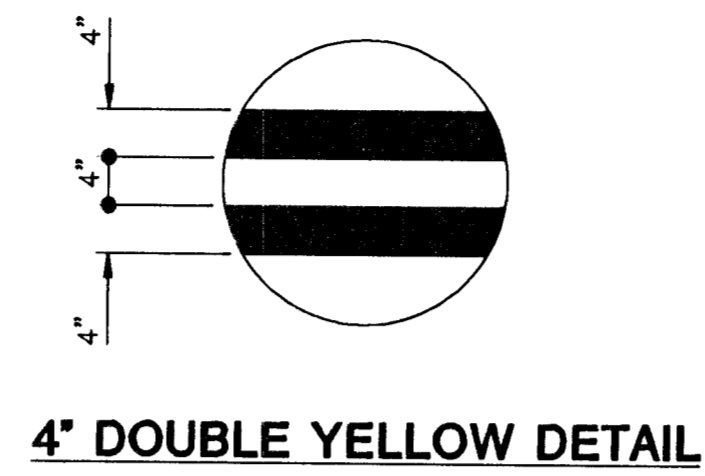
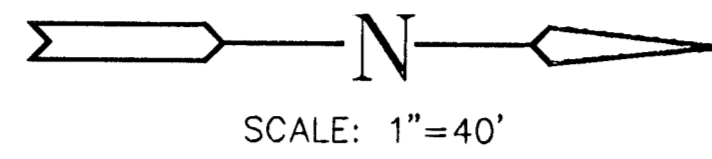
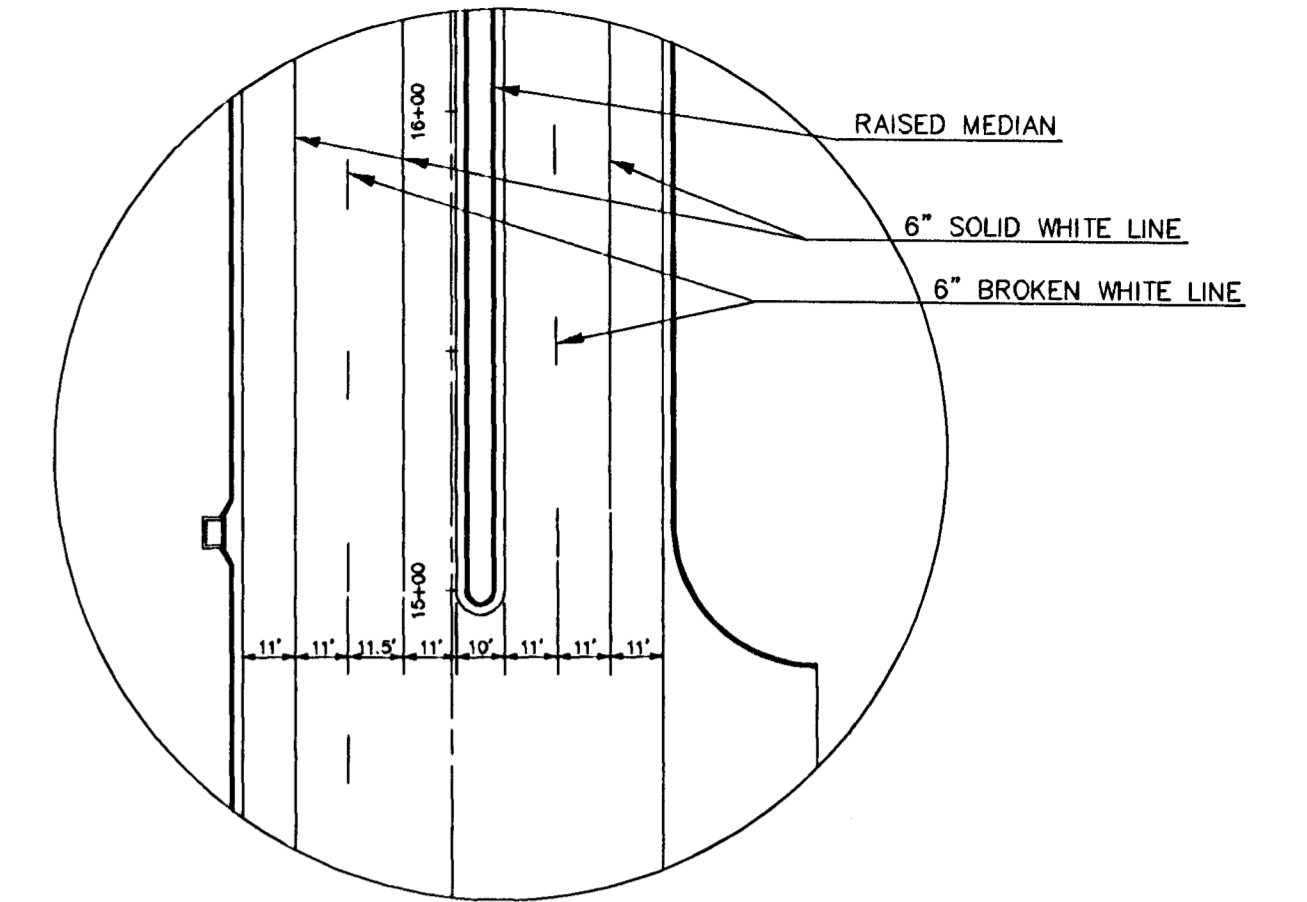

DETAIL FOR STA. 15+00 THRU 17+50

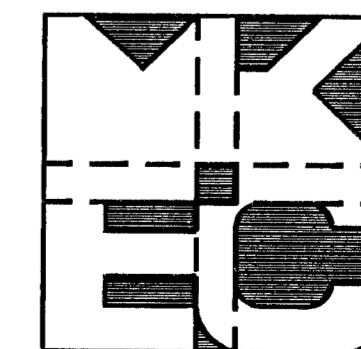
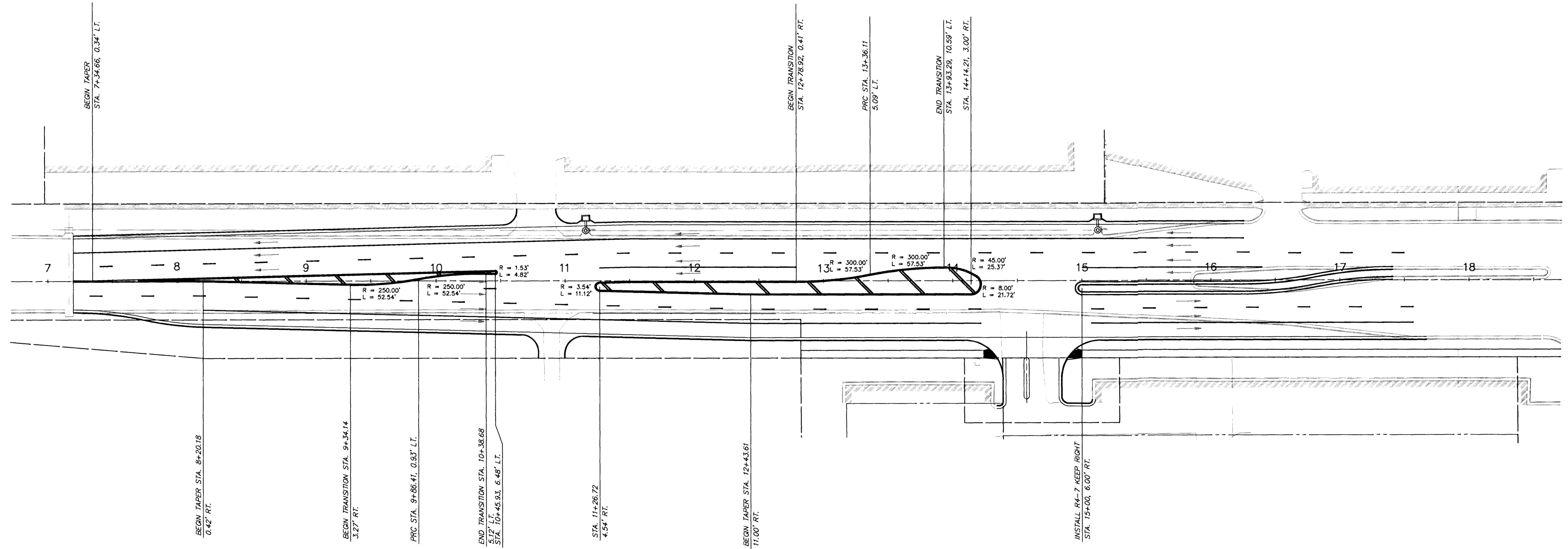

**BRADLEY FAIR  
NORTH ROCK ROAD**  
**DETAILS & LOCATIONS  
FOR  
PAVEMENT MARKING  
& SIGNING**

MID-KANSAS ENGINEERING CONSULTANTS, INC.  
 3500 N. ROCK ROAD #800  
 WICHITA, KANSAS 67226

Design  
JTC  
 Drawn by  
JTC  
 Checked by  
GJA  
 Date  
JUNE/94  
 Job no.  
9392STRP

Sheet **9**  
 of **12**