

**STANDARD WHEELCHAIR RAMP CONSTRUCTION DETAIL FOR STREETS WITH COMBINED CURB & GUTTER (TYPE A)**

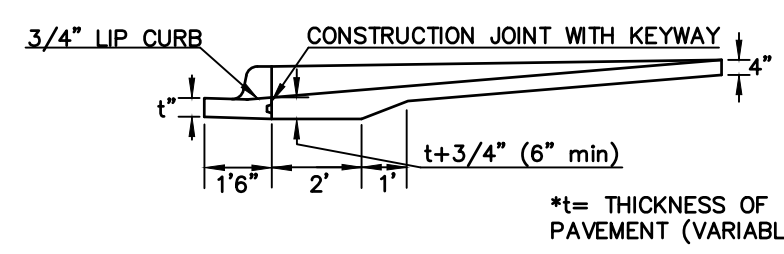

SECTION A-A

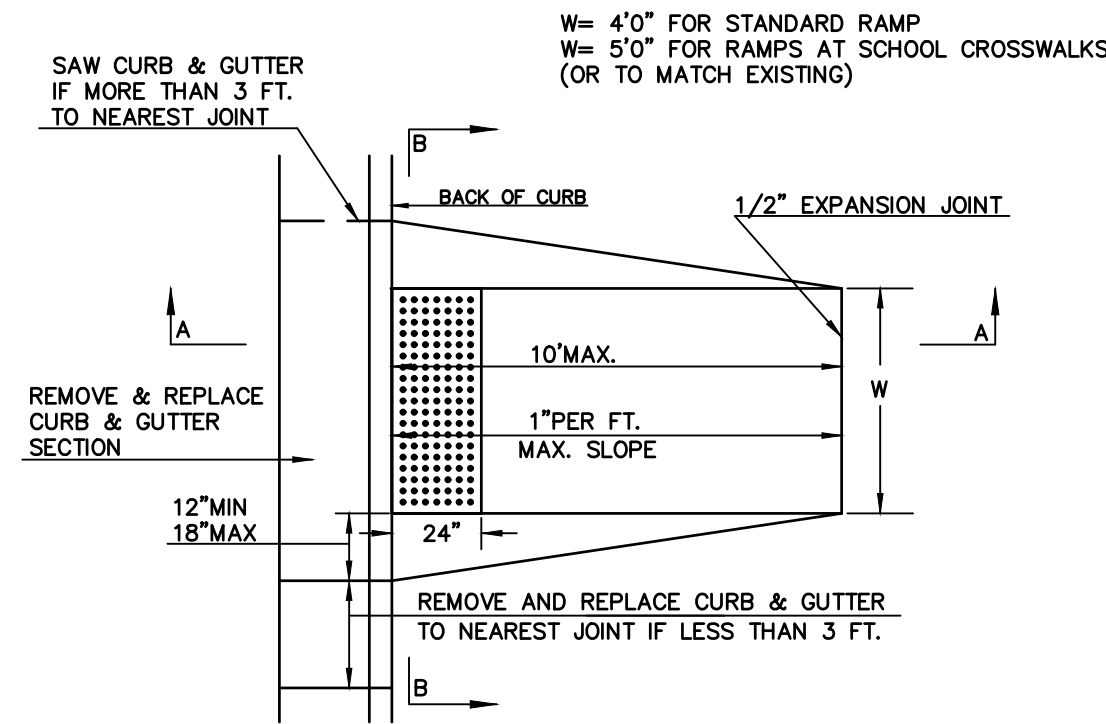
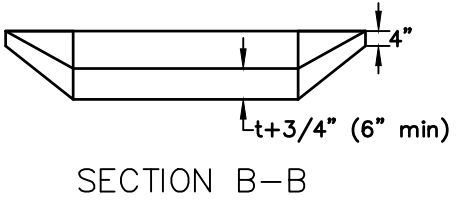

SECTION B-B

**STANDARD WHEELCHAIR RAMP CONSTRUCTION DETAIL FOR CONCRETE STREETS WITH MONOLITHIC CURB (TYPE A)**

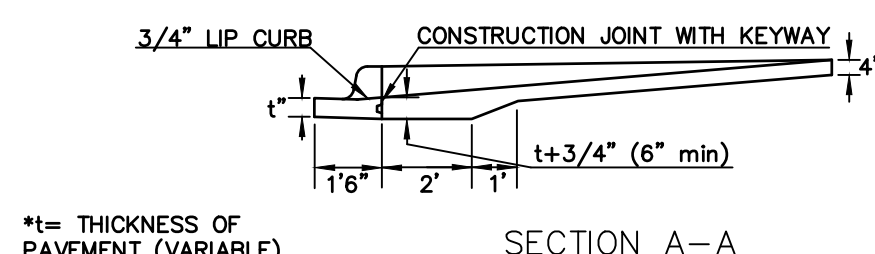
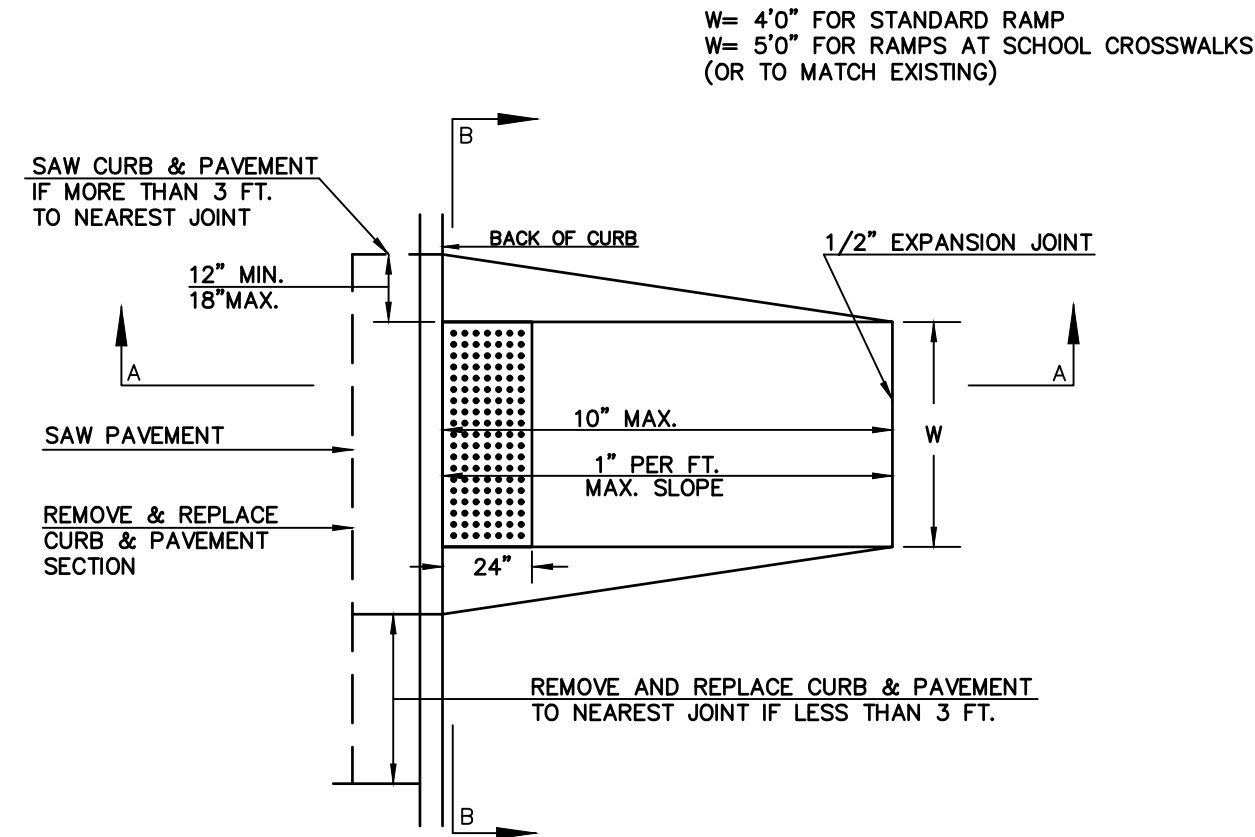

SECTION A-A

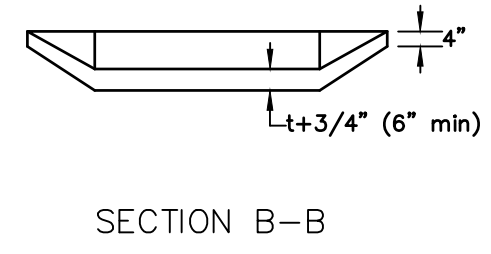

SECTION B-B

**STANDARD WHEELCHAIR RAMP CONSTRUCTION DETAIL FOR STREETS WITH COMBINED CURB & GUTTER AND FULL WALK (TYPE B)**

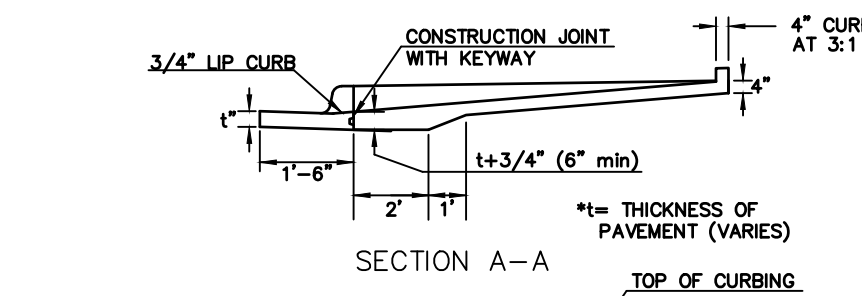
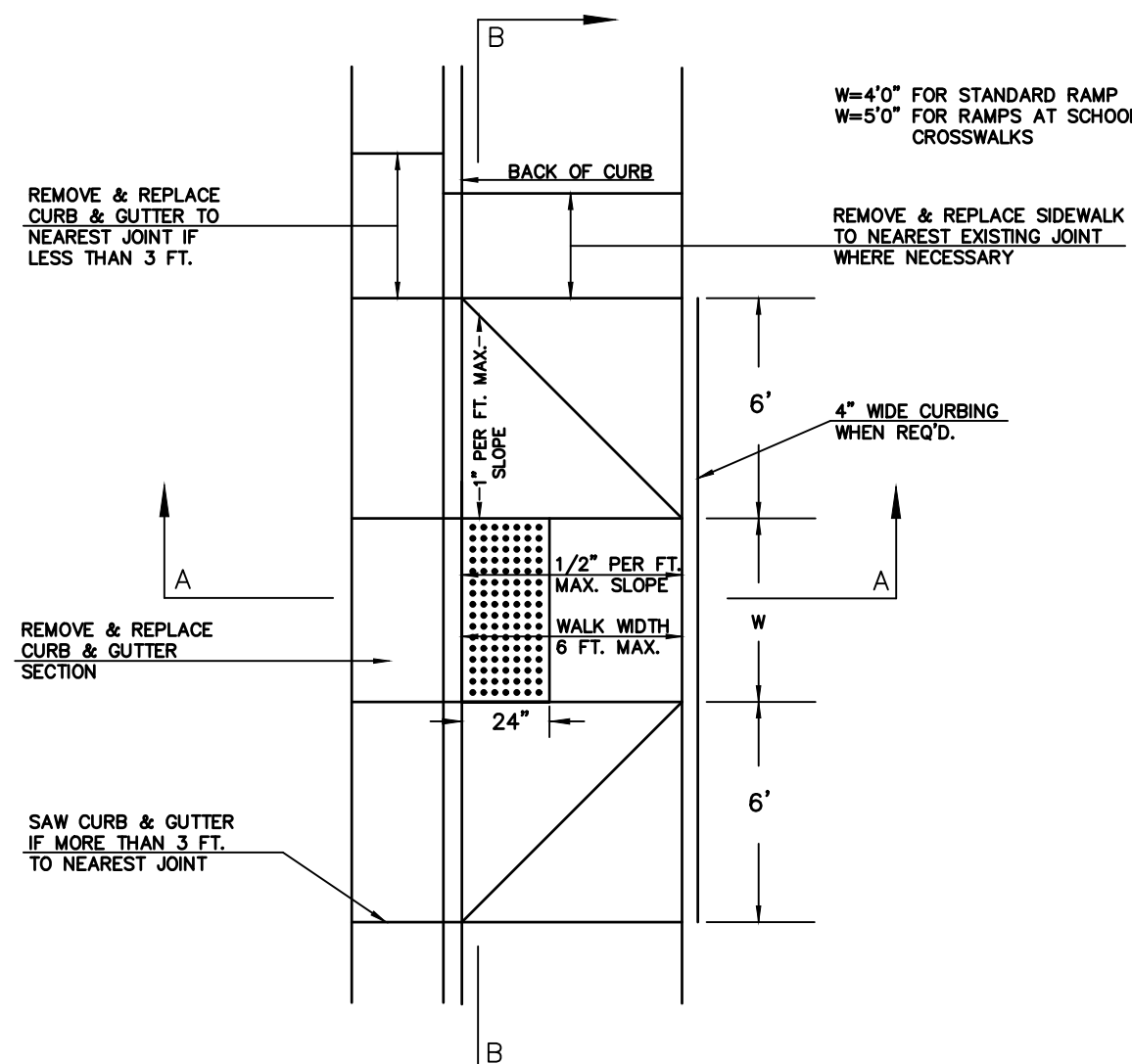

SECTION A-A

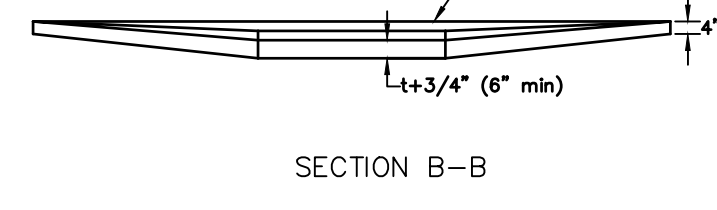

SECTION B-B

**STANDARD WHEELCHAIR RAMP CONSTRUCTION DETAIL FOR STREETS WITH MONOLITHIC CURB AND FULL WALK (TYPE B)**

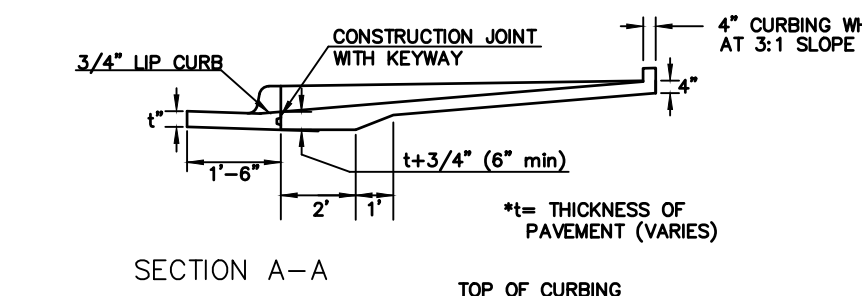
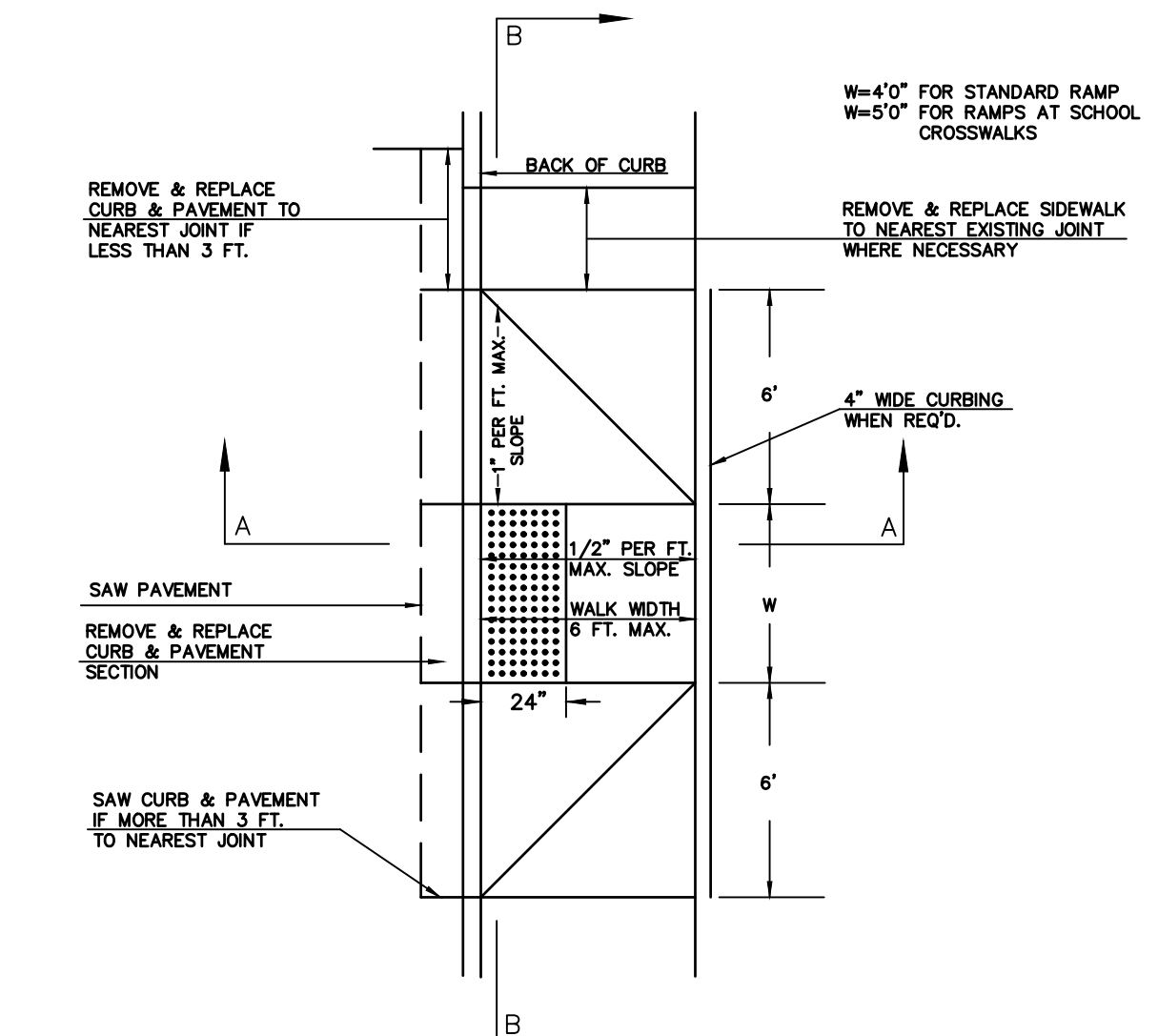

SECTION A-A

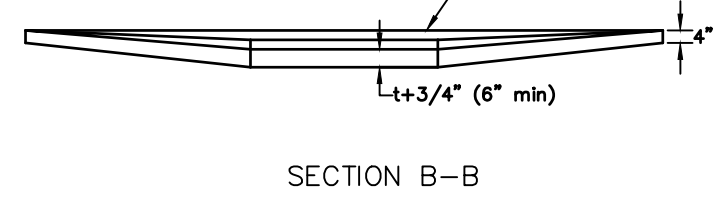

SECTION B-B

**STANDARD WHEELCHAIR RAMP CONSTRUCTION DETAIL FOR STREET WITH COMBINED CURB AND GUTTER ON RADIUS WITH 6'+ FROM BACK OF CURB TO PROPERTY CORNER (TYPE C)**

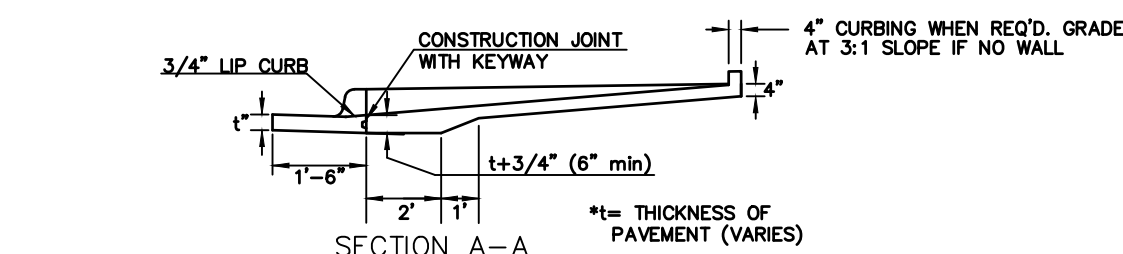
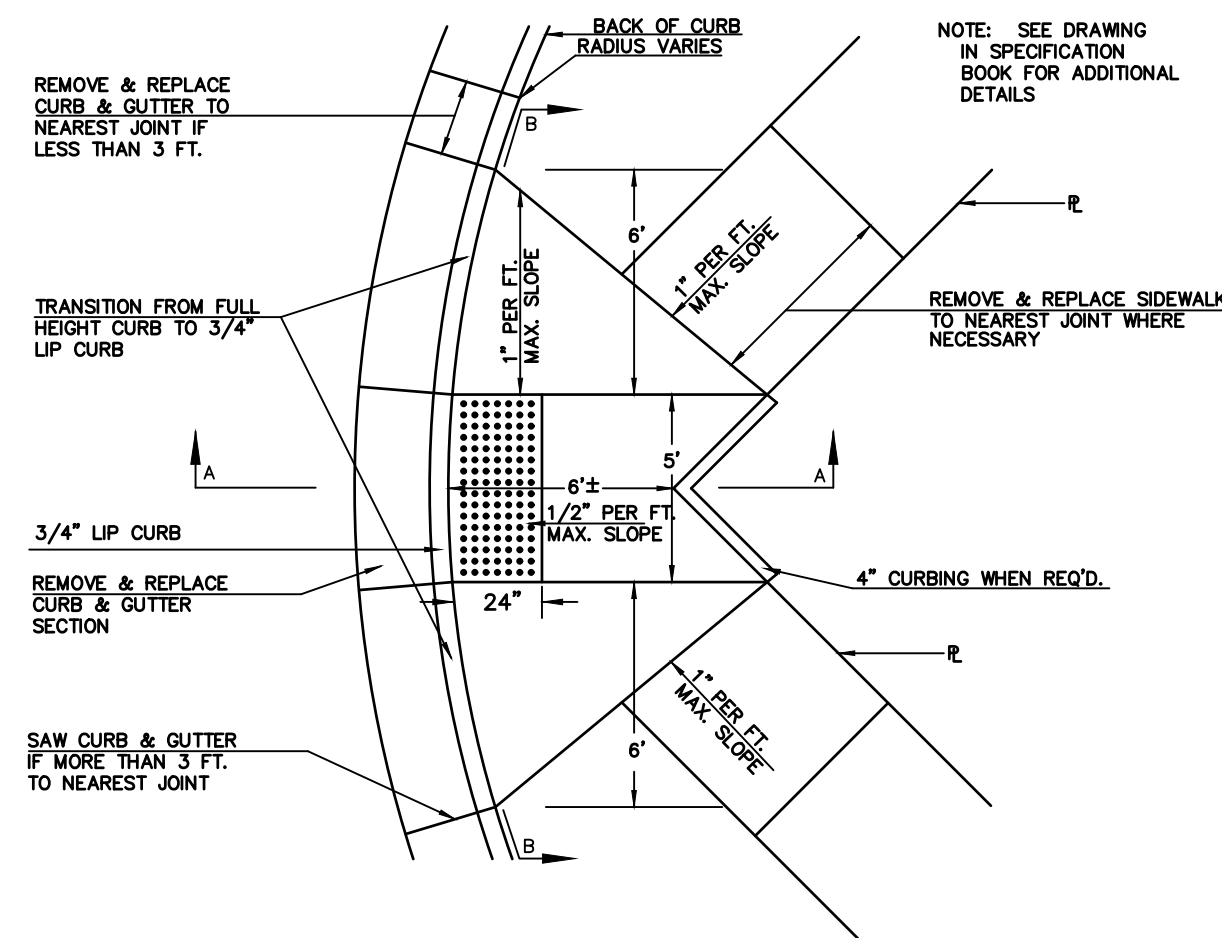

SECTION A-A

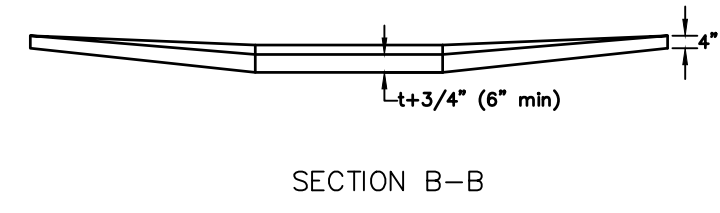

SECTION B-B

**STANDARD WHEELCHAIR RAMP CONSTRUCTION DETAIL FOR STREET WITH MONOLITHIC CURB ON RADIUS WITH 6'+ FROM BACK OF CURB TO PROPERTY CORNER (TYPE C)**

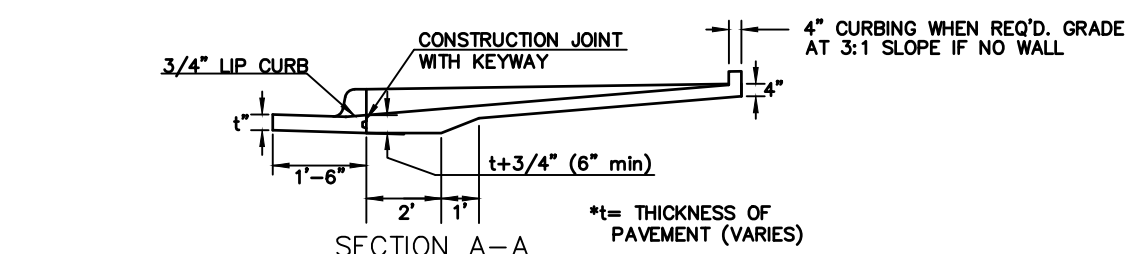
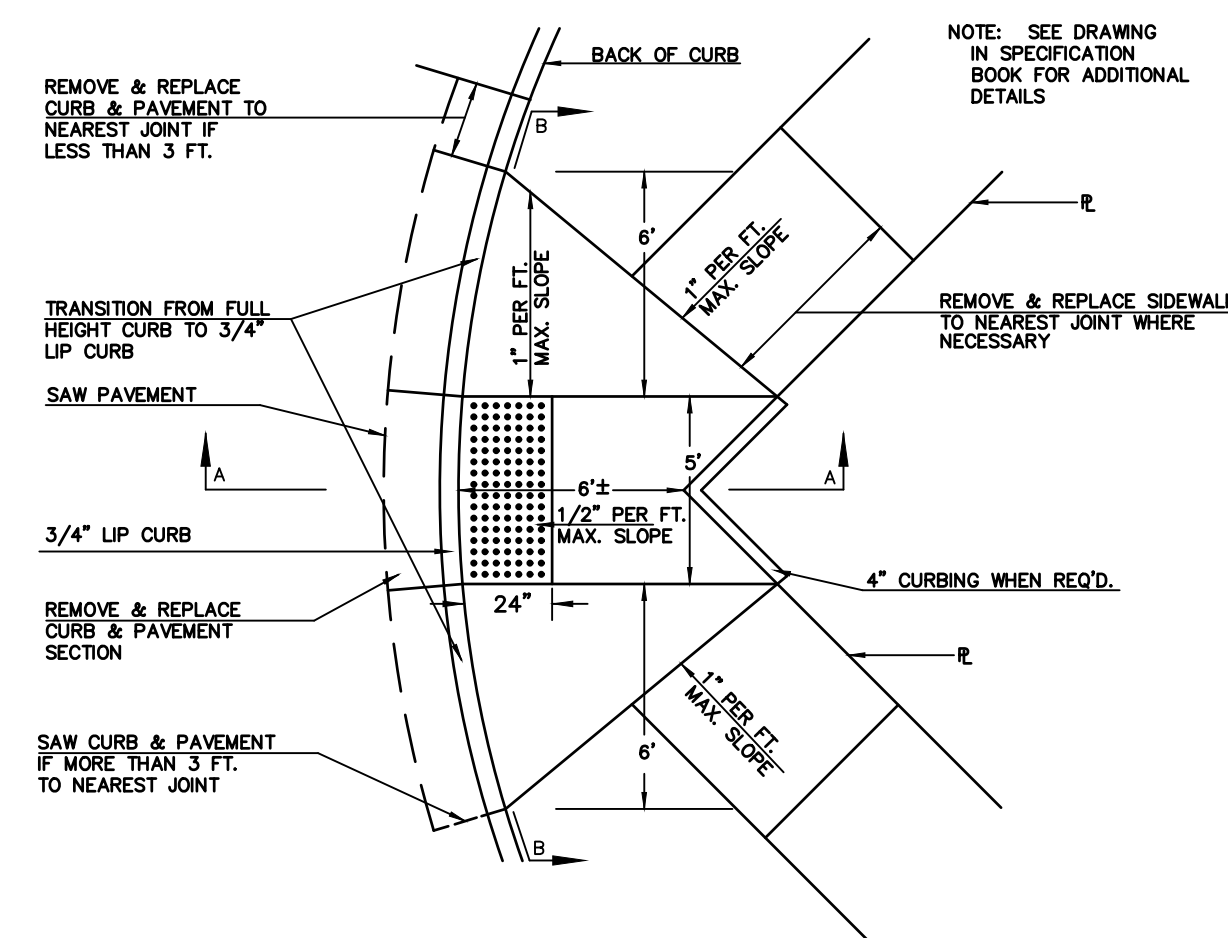

SECTION A-A

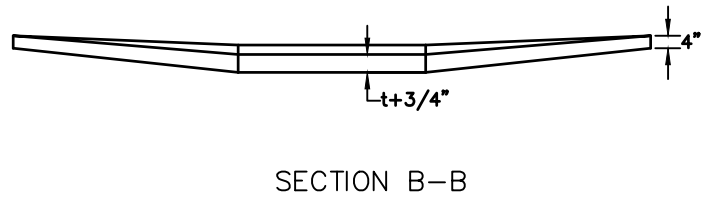

SECTION B-B

**STANDARD WHEELCHAIR RAMP CONSTRUCTION DETAIL FOR STREETS WITH COMBINED CURB & GUTTER WITH ONE FULL SIDEWALK (TYPE D)**

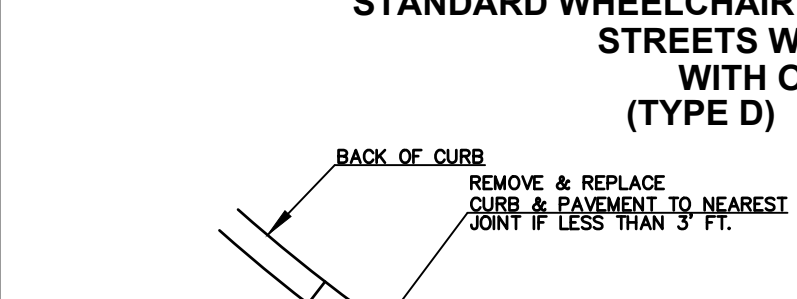
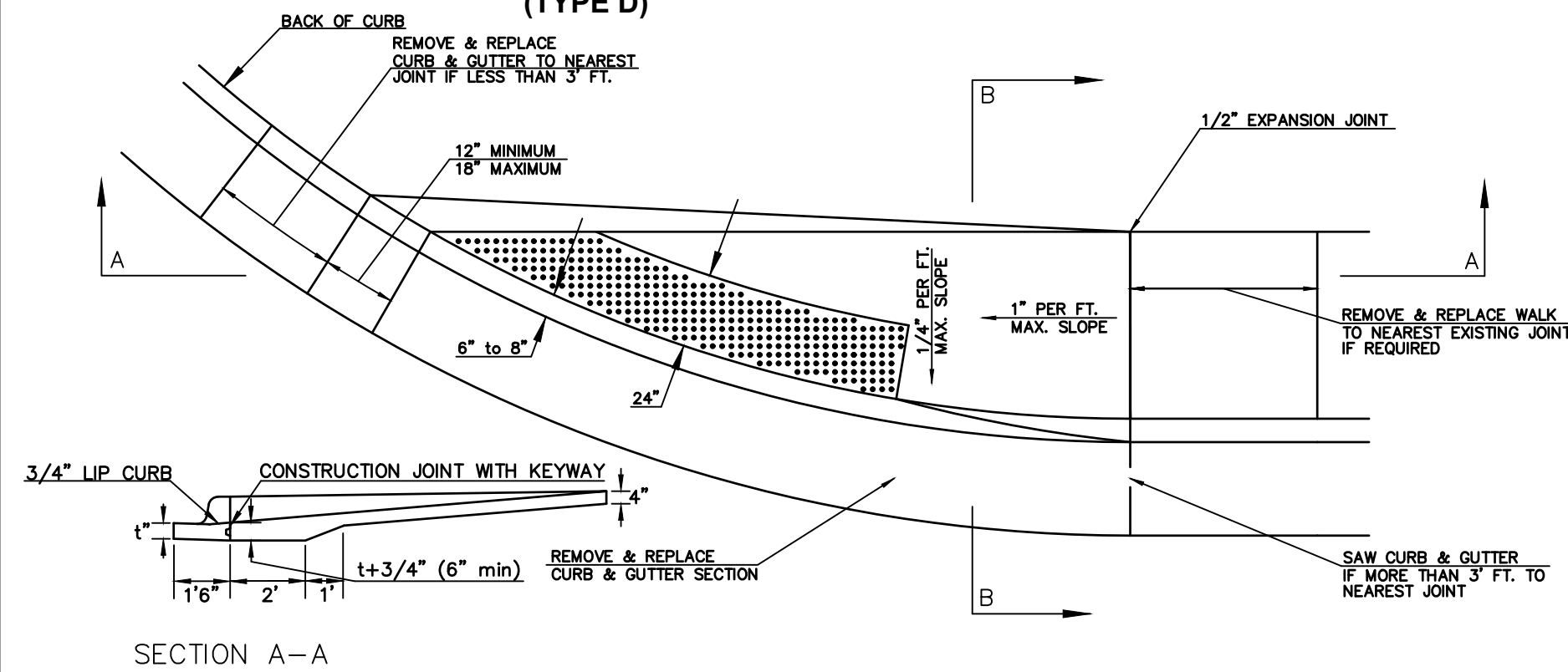

SECTION A-A

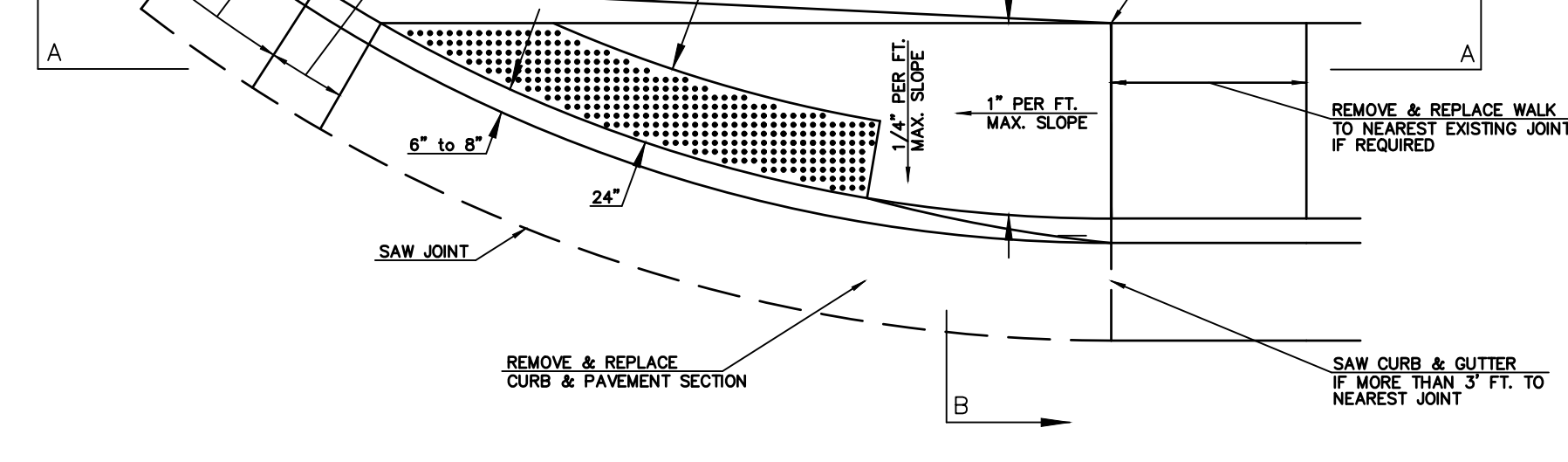

SECTION B-B

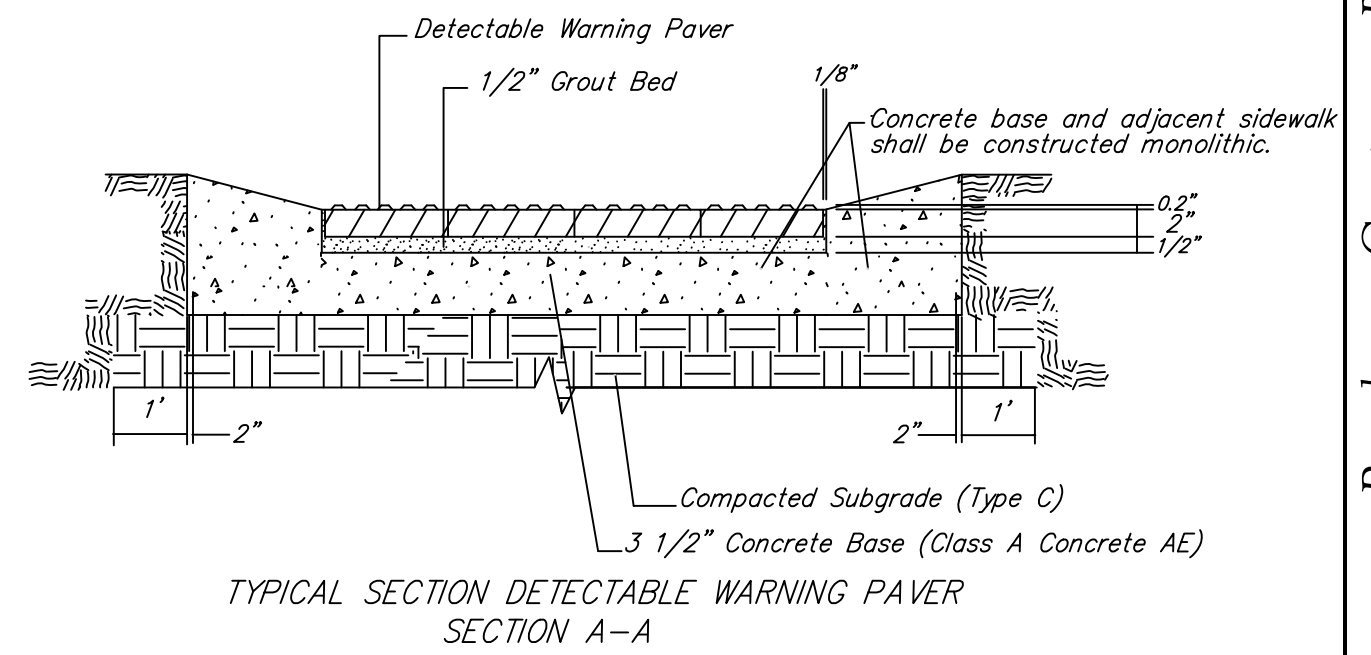

**TYPICAL SECTION DETECTABLE WARNING PAVER SECTION A-A**

NOTE: HANOVER DETECTABLE WARNING PAVERS (OR AN APPROVED ALTERNATE) SHALL BE USED IN ALL WHEELCHAIR RAMPS. THE 11 3/4" RED 15' PAVER SHALL BE USED IN ALL APPLICATIONS. HANOVER ARCHITECTURAL PRODUCTS 240 BENDER ROAD HANOVER, PA 17331 1-717-637-0500 www.hanoverpavers.com

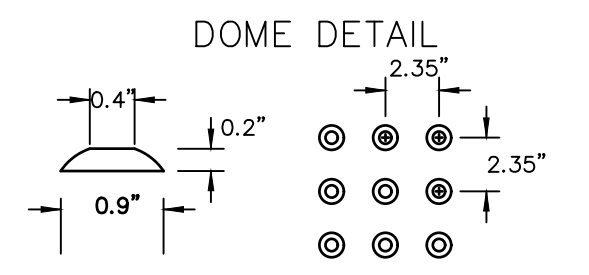

DOME DETAIL