

EXC = 28.5  
LF = 23.5  
CF = 2.8

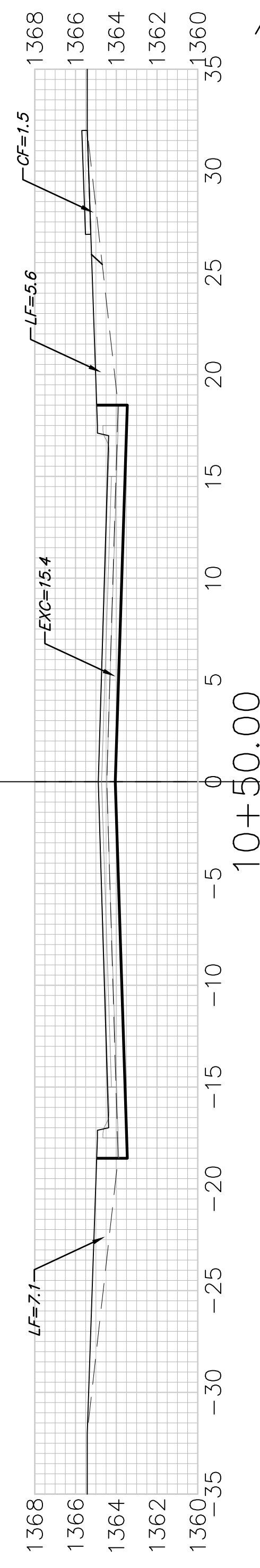

EXC = 28.5  
LF = 23.5  
CF = 2.8

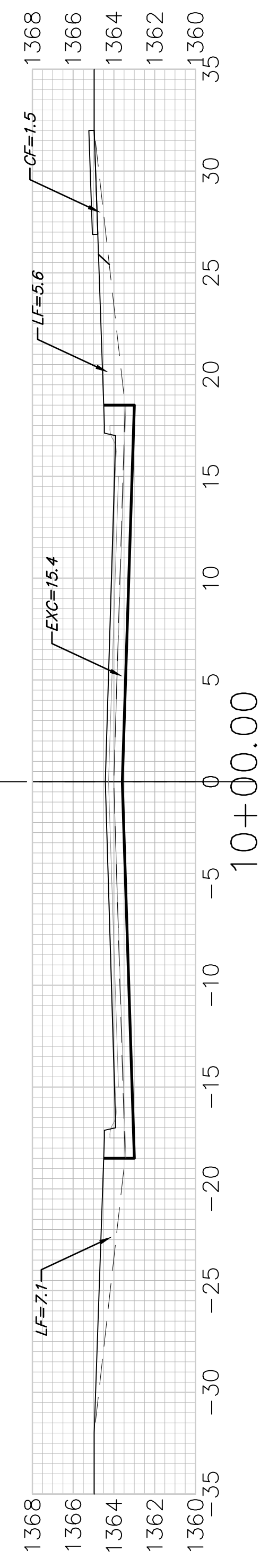

EXC = 28.5  
LF = 23.5  
CF = 2.8

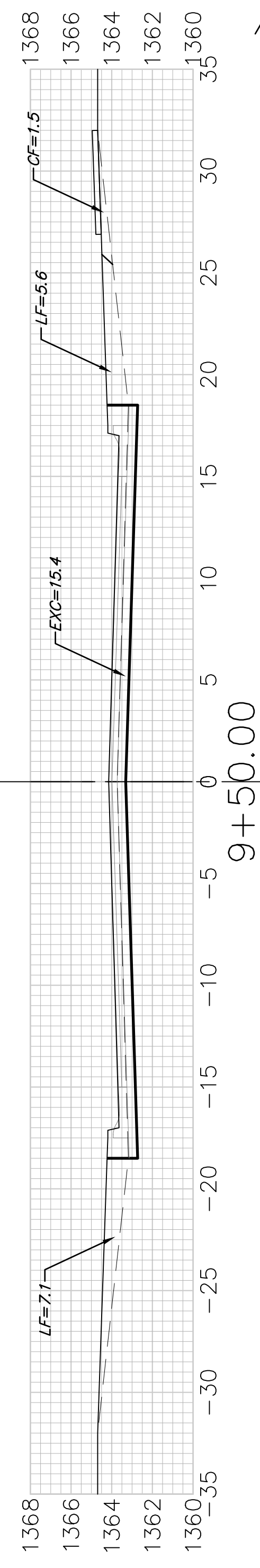

EXC = 28.5  
LF = 23.5  
CF = 2.8

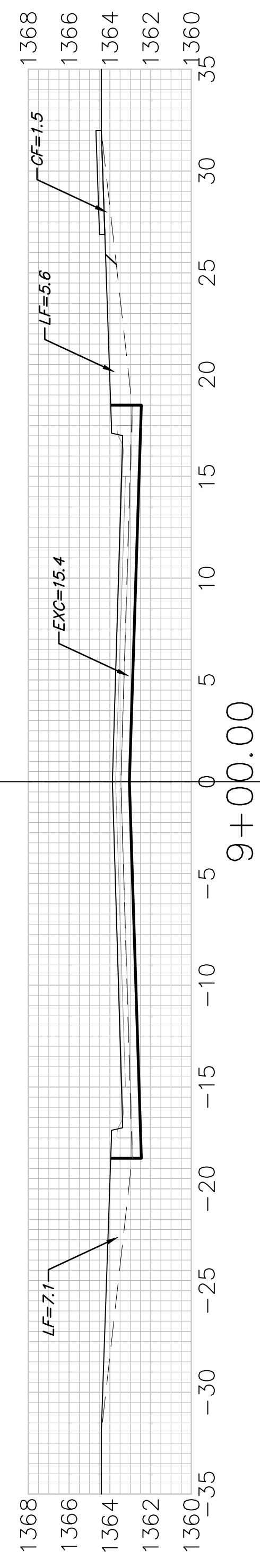

EXC = 28.5  
LF = 23.5  
CF = 2.8

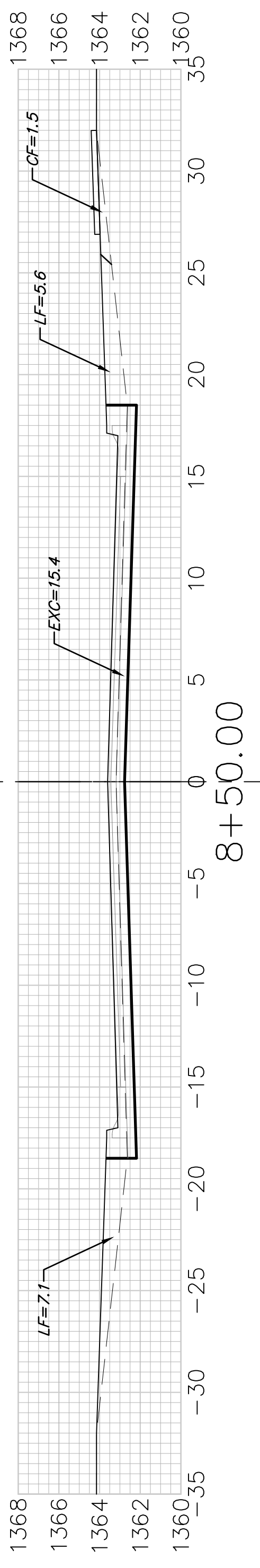

EXC = 28.5  
LF = 23.5  
CF = 2.8

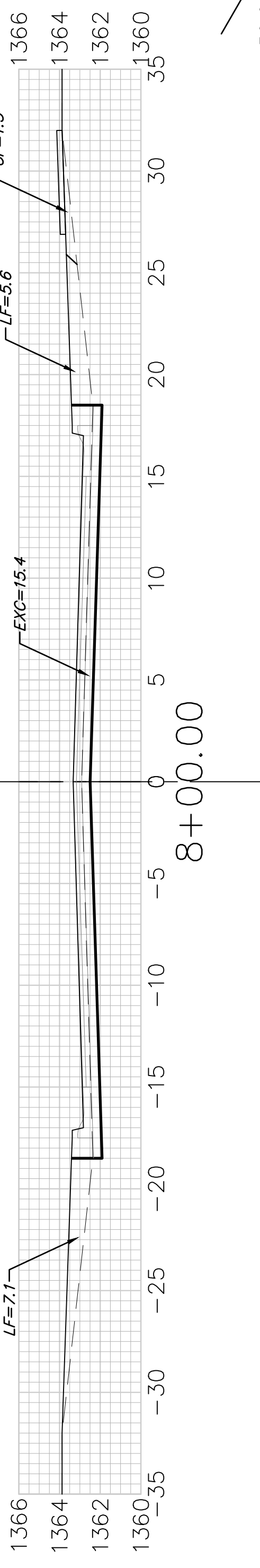

EXC = 28.5  
LF = 23.5  
CF = 2.8

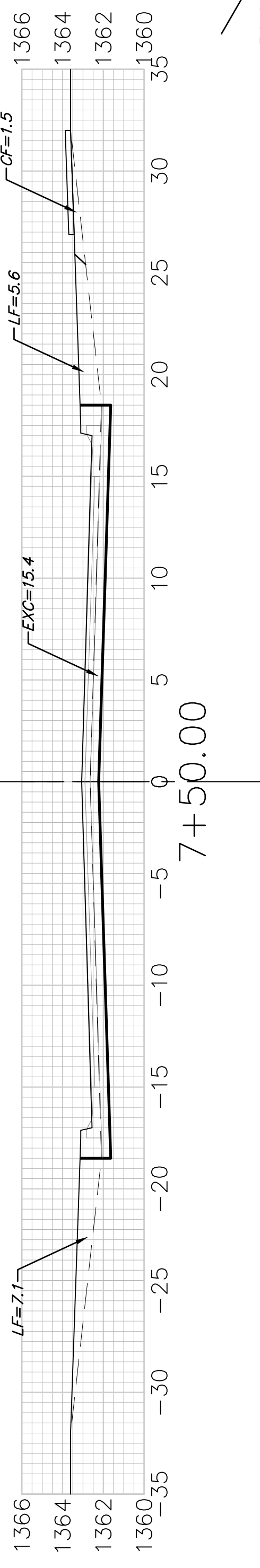

EXC = 28.5  
LF = 23.5  
CF = 2.8

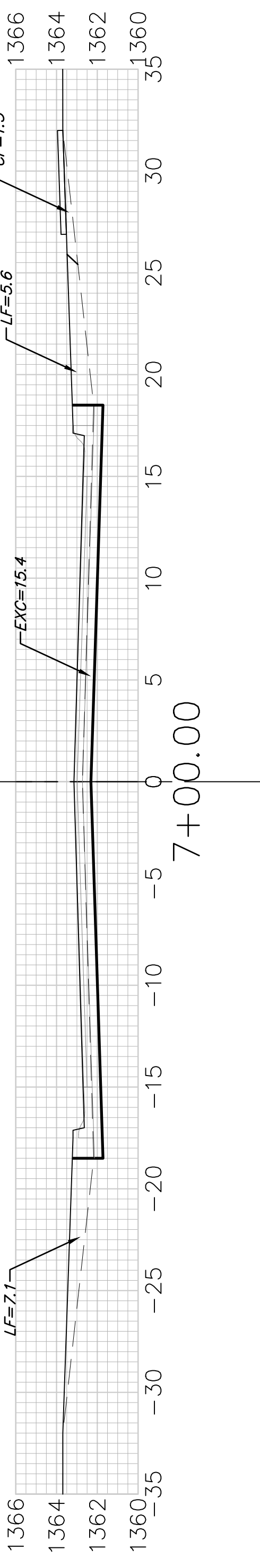

SAGEBRUSH

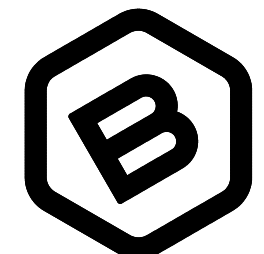

**BAUGHMAN COMPANY**

315 Ellis St.  
Wichita, KS 67211  
316-262-7271  
BaughmanCo.com

NRD ADDITION  
Phase I & Entrance

**CROSS SECTIONS**

STREET IMPROVEMENTS

PROJECT NUMBER:

DESIGN: NBW DRAWN: TMS  
DATE: December 6, 2021

SHEET OF  
**33 47**

Sheet Totals  
Excavation = 228.0 C.Y.  
Loose Fill = 188.0 C.Y.  
Compacted Fill = 22.4 C.Y.