

Combined Curb & Gutter (6")

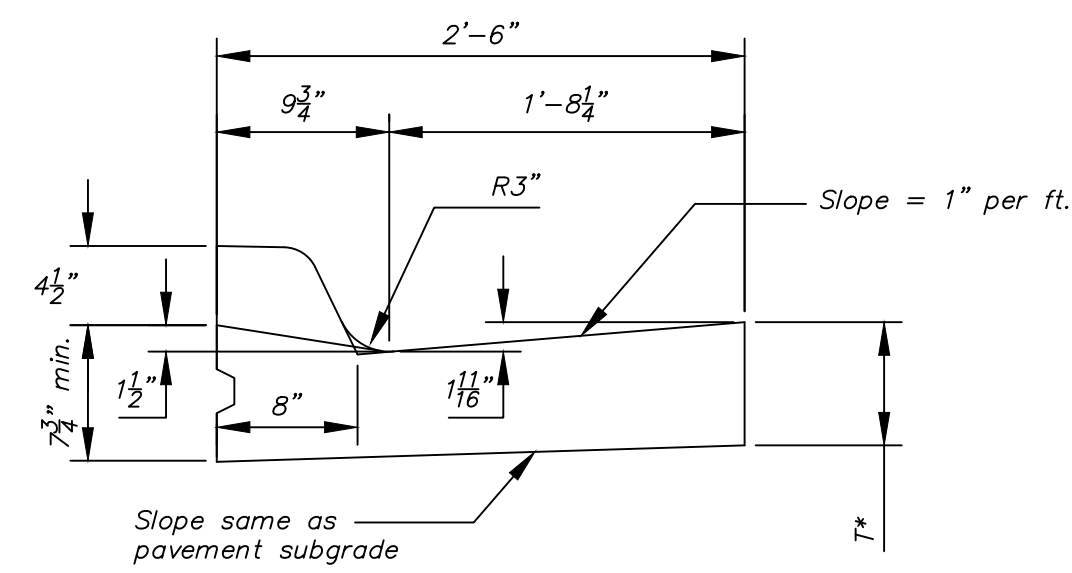

Combined Curb & Gutter (1 1/2")

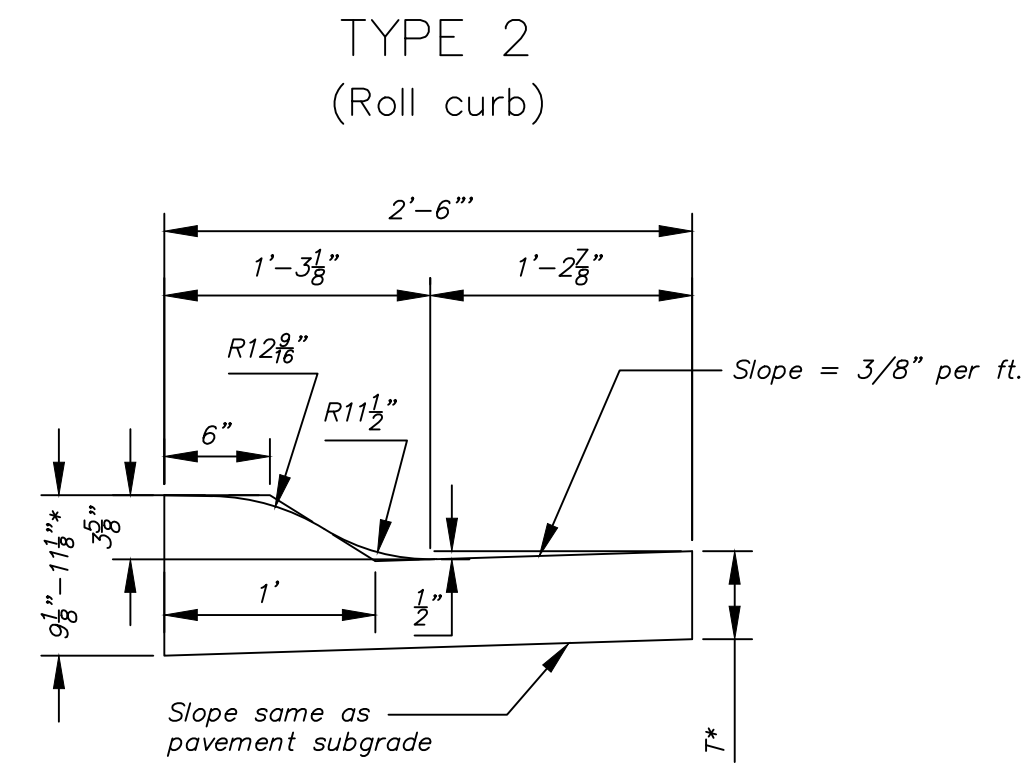

Combined Curb & Gutter (3 5/8")

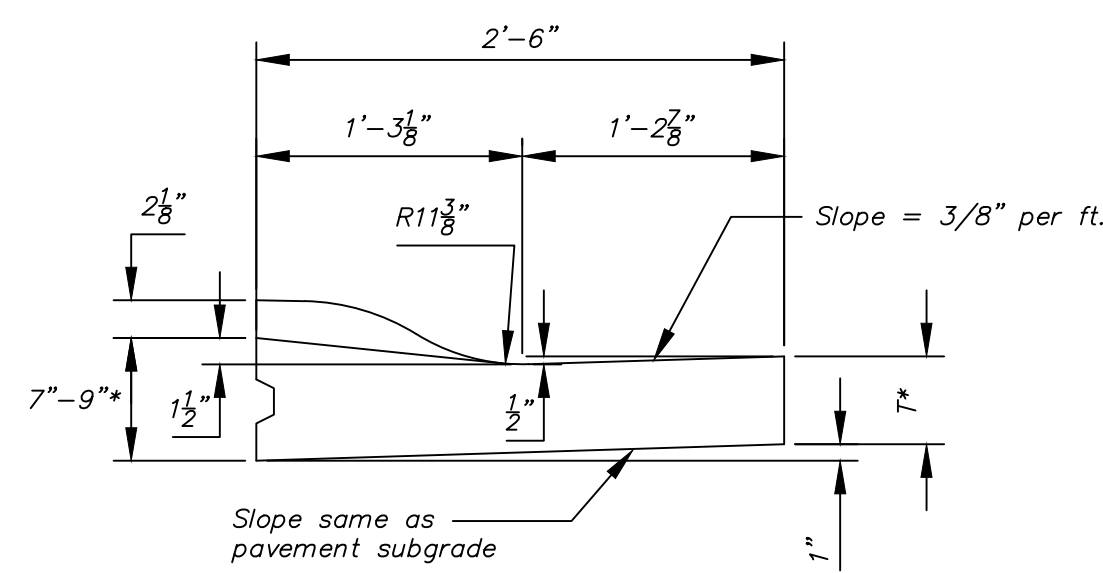

Combined Curb & Gutter (1 1/2")

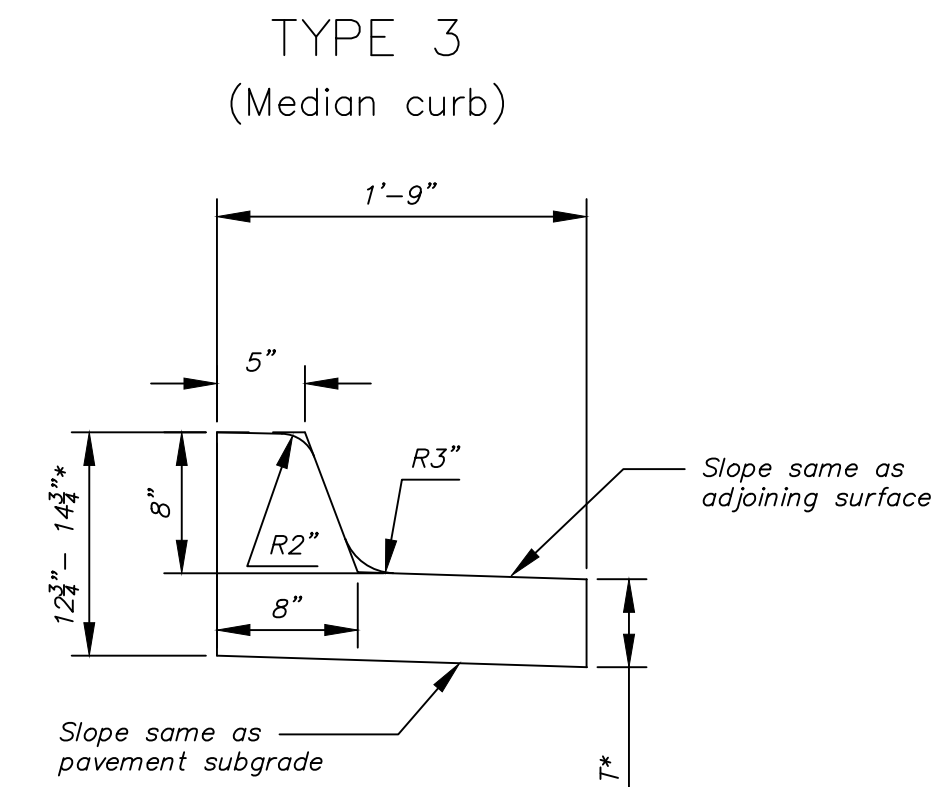

Combined Curb & Gutter (8")

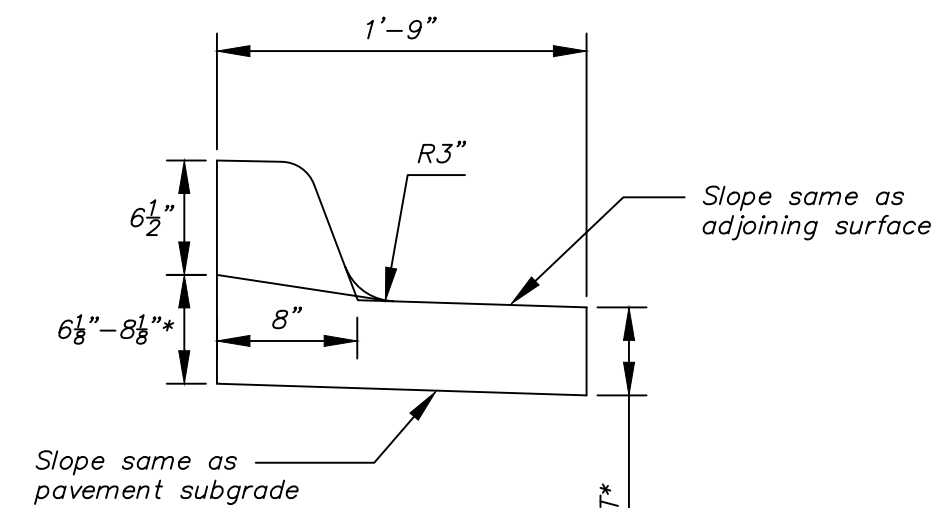

Combined Curb & Gutter (1 1/2")

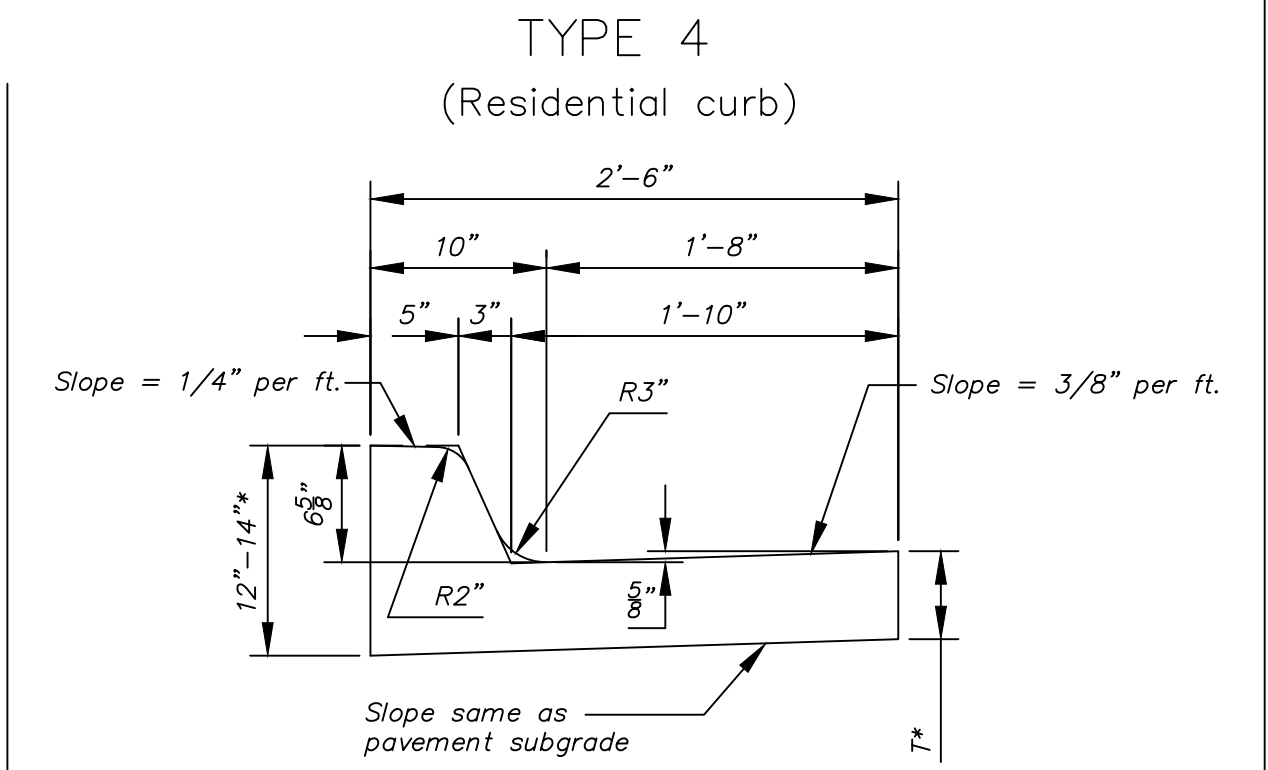

Combined Curb & Gutter (6 5/8")

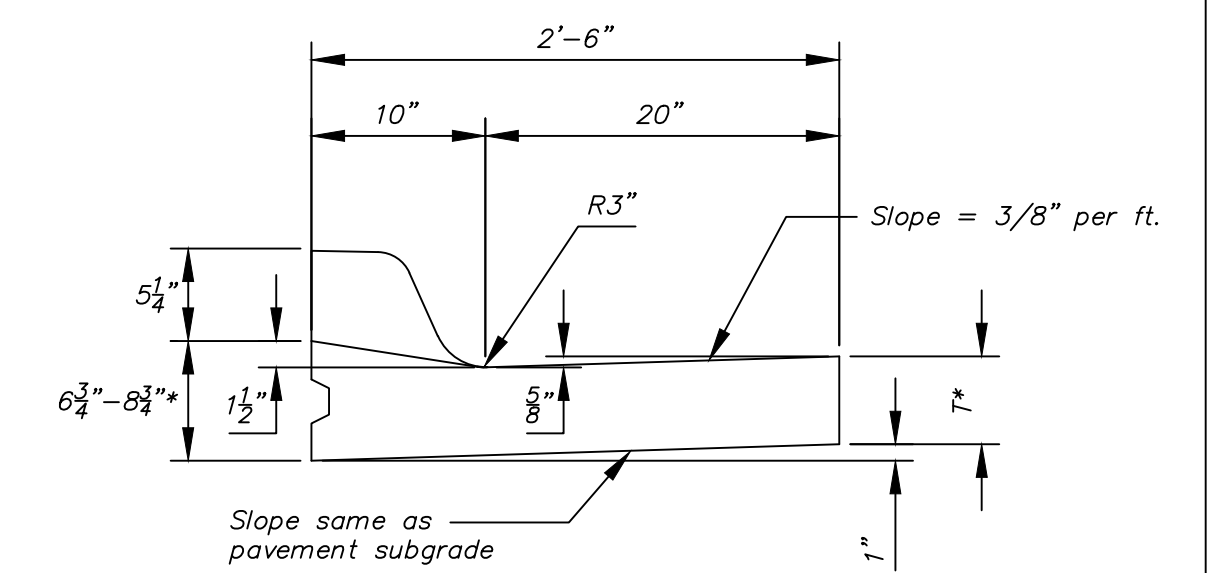

Combined Curb & Gutter (1 1/2")

T* = Thickness of curb to adjust with pavement thickness

GENERAL NOTES

- Expansion (isolation) joints shall be constructed a maximum of 300' apart and at all PIs, PCs, cul-de-sac quadrants, and ends of returns.
- Contraction joints shall be constructed a minimum of 12' apart.
- Joint sealer shall be required at all joints on arterial and industrial streets and at intersections on residential streets.

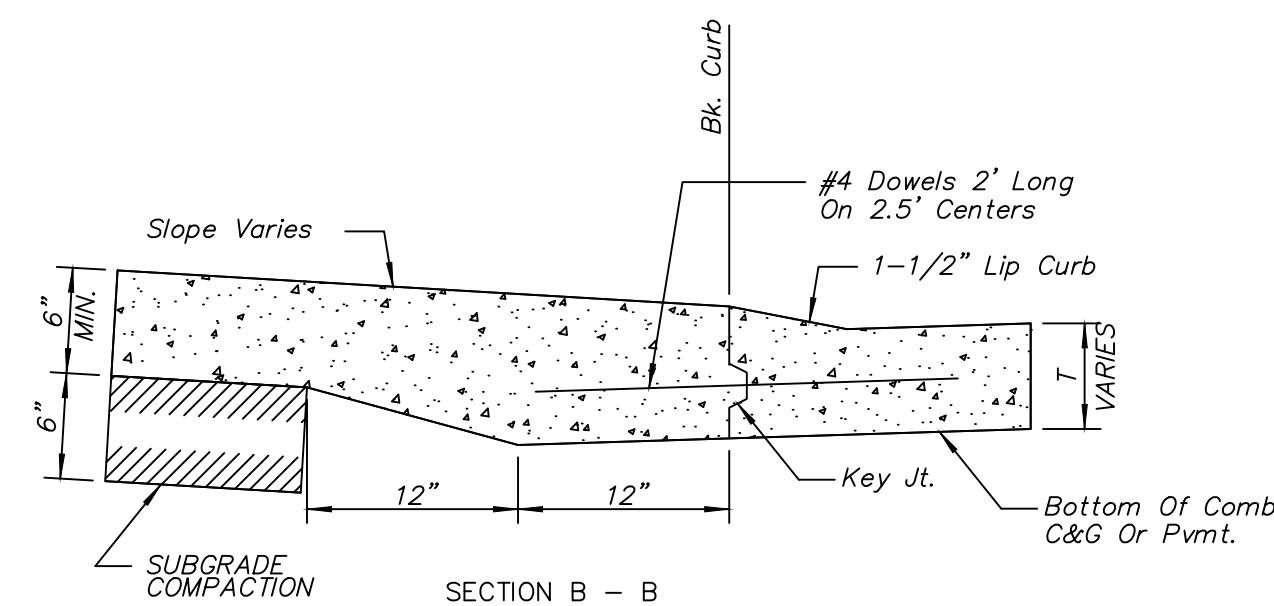

BACK OF CURB DETAIL

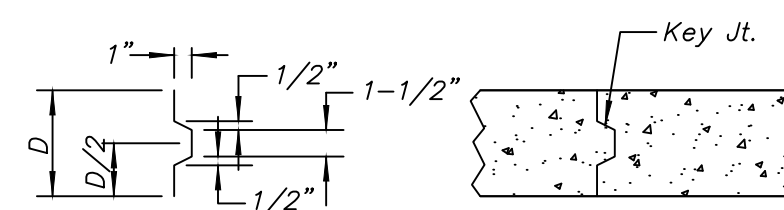

ALT. LONGITUDINAL CONSTRUCTION JOINT

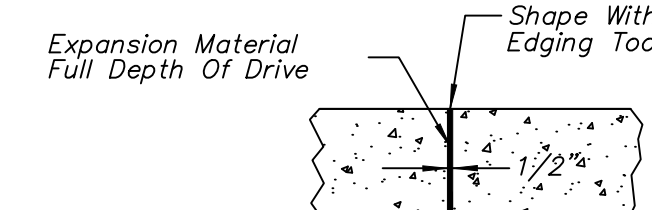

EXPANSION JOINT (E.J.)

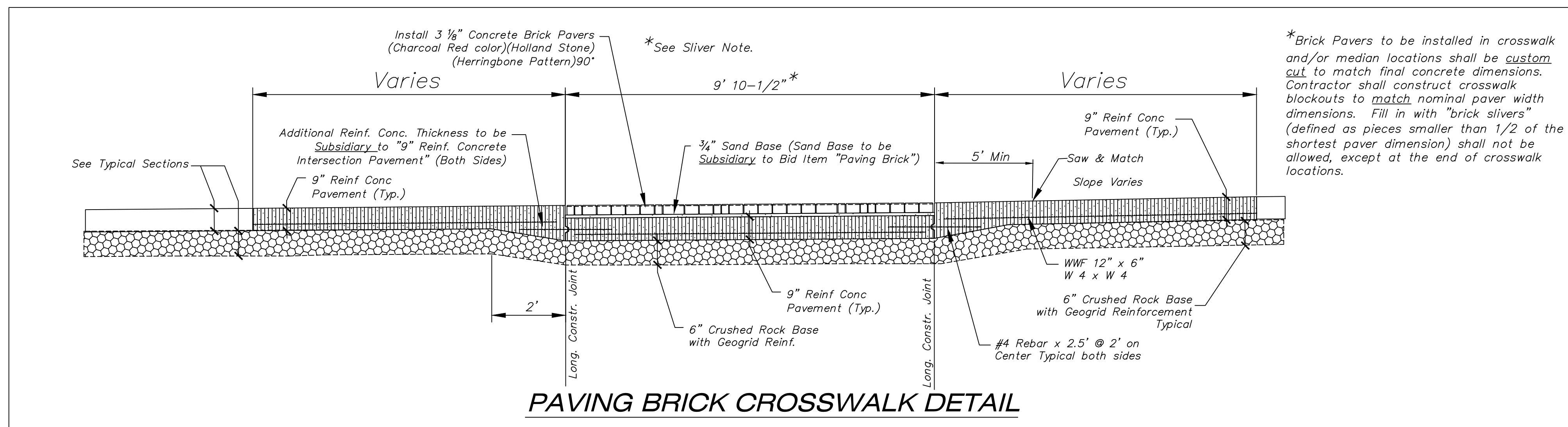

PAVING BRICK CROSSWALK DETAIL



REVISION: OCTOBER 2015		
CURB & GUTTER & PAVING BRICK CROSSWALK DETAILS		
CITY ENGINEER GARY JANZEN, P.E.		
PROJECT NUMBER	OCA NUMBER	DATE
CITY ENGINEER'S OFFICE CITY HALL - SEVENTH FLOOR 455 NORTH MAIN STREET WICHITA, KANSAS 67202-1620 (316) 268-4501	SHEET	

KS	CHK
JT	DWN
SRB	DSN
INITIAL ISSUE	DESCRIPTION
4-15-22	REV DATE
0	REV
3	0

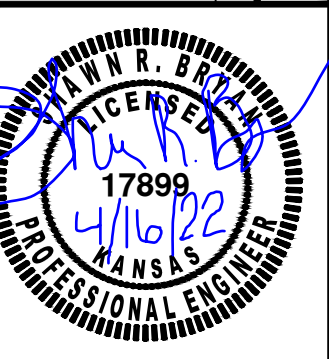

SHAWN R. BRYAN
ENGINEER
KS # 17899

200 N. EMPORIA, SUITE 100
WICHITA, KANSAS 67202
PH. (316) 440-4304 | FAX. (316) 440-4309
www.kveeng.com | www.kveing.com

KAW VALLEY ENGINEERING
KAW VALLEY ENGINEERING, INC., IS AUTHORIZED TO OFFER ENGINEERING SERVICES BY KANSAS STATE CERTIFICATE OF AUTHORIZATION # E-113. EXPIRES 12/31/22

SYCAMORE POND ADDITION
W 50TH STREET S & S OSAGE CIRCLE
WICHITA, KANSAS

PHASE II - PAVEMENT IMPROVEMENT PLANS
DETAIL SHEET

PROJ. NO. G19-1259-1
DESIGNER TRA DRAWN BY JT
CFN 1259-1P_DET
SHEET 3