

NOTE TO DESIGNER: Mast arm lengths shall be in 6' increments (18' to 60'). If a longer mast arm is required, signal pole foundation design calculations must be submitted to the City of Wichita for review. The pad mounted 332L cabinet is typically used unless approved otherwise by City of Wichita Traffic Engineer. 5-Sections heads for left turn phase must be approved by the City of Wichita Traffic Engineer.

CHART A SIGNAL SUMMARY

Signal Face Arrangement	No. Sections (Per Face)	Signal Mounting Type	Quantity
A	3	Mast Arm w/ Backplate	6
H	4	Mast Arm w/ Backplate	4
K	1	Side-of-Pole	8
A	3	Side-of-Pole	4

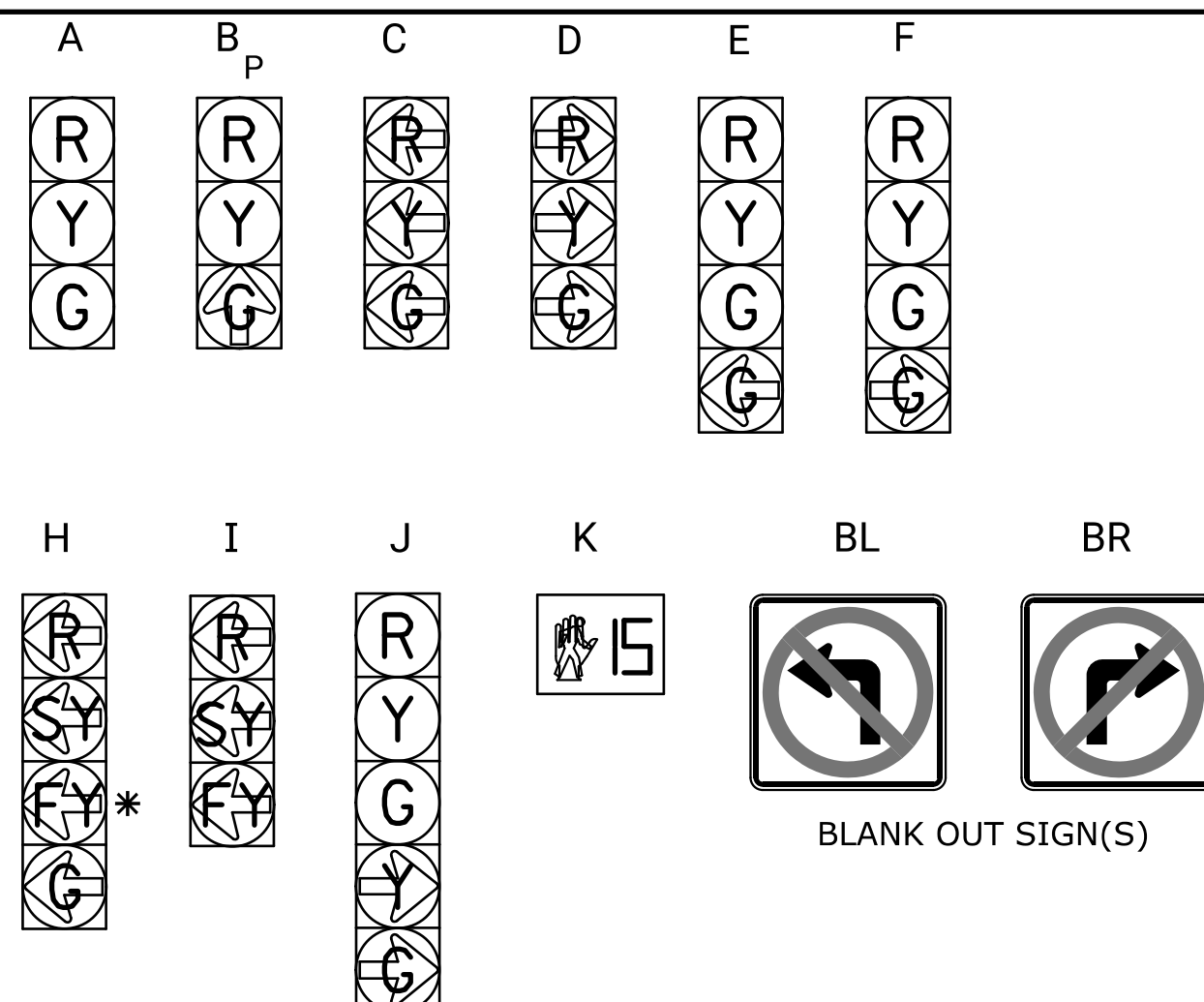

- NOTES:
- *SHALL NOT BE DISPLAYED WHEN OPERATING IN THE PROTECTED ONLY MODE.
 - ALL LENSES ARE L.E.D. UNLESS OTHERWISE NOTED.
 - SUBSCRIPT "P" INDICATED PROGRAMMED SIGNALS.
 - ALL LENSES SHALL BE 12" DIA. UNLESS OTHERWISE NOTED. PEDESTRIAN DISPLAY (K) SHALL BE RECTANGULAR WITH A WIDTH OF 18" AND HEIGHT OF 16".
 - BLANK OUT SIGN SIZE SHALL MEET MUTCD REQUIREMENTS FOR APPLICABLE STATIC VERSION OF THE SIGN.

CHART B TRAFFIC SIGNAL POLES

Pole Height	Signal Arm Length	Signal Arm Mounting Height	No. of Signals on Arm	Signal Spacing	Luminaire Arm Length	Luminaire Mounting Height	Quantity
35.0'	66.0'	19.0'	3	37', 48', 60'	15.0'	40.0'	1
20.5'	48.0'	19.0'	2	27.5', 39'	-	-	-
35.0'	42.0'	19.0'	3	16.5', 27.5', 38.5'	15.0'	35.0'	1
35.0'	42.0'	19.0'	2	25.5', 35.5'	15.0'	35.0'	1

CHART C OVERHEAD STREET NAME SIGNS

Sign	Legend	Length	Quantity
1	29th St 11100 E	78	2
2	Greenwich 3000 N	96	2

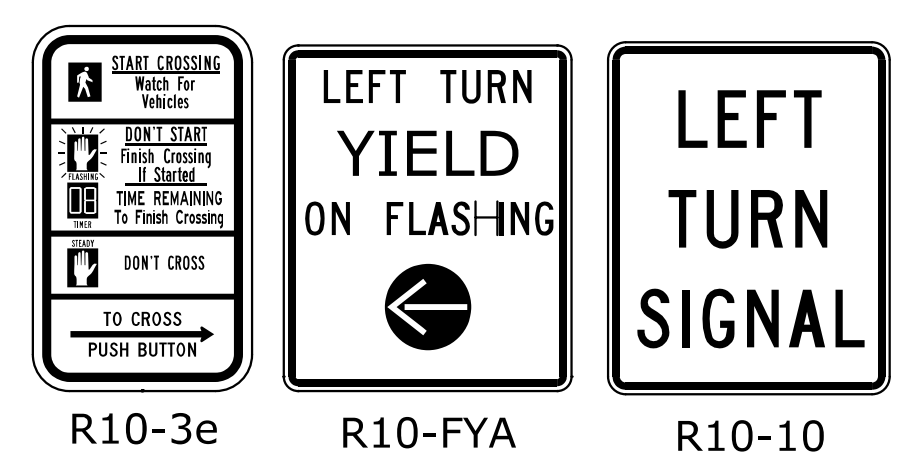

BILL OF MATERIALS

-Quantities for Information Only-

Item	Quantity	Unit	Spec. No.	Note
CONTROLLER UNIT	1	EACH	703.2.1	TRAFFICWARE 2070LX V85
CONFLICT MONITOR	1	EACH	703.2.2	
LOAD SWITCH	16	EACH	703.2.3	
FLASHER	2	EACH	703.2.4	
FLASH TRANSFER RELAY	6	EACH	703.2.5	
SURGE PROTECTOR	1	EACH	703.2.6	
DC ISOLATOR	3	EACH	703.2.7	
AC ISOLATOR		EACH	703.2.8	
GPS CLOCK	1	EACH	703.2.9	
POWER STRIP	1	EACH	703.2.11	NOTE 7
AUXILLARY OUTPUT FILE	1	EACH	-	NOTE 6
POLE MOUNTED CABINET (336L)		EACH	703.2.11	
PAD MOUNTED CABINET (332L)	1	EACH	703.2.11	
PAD MOUNTED CABINET (342) (DOUBLE)		EACH	703.2.11	
BATTERY BACKUP (BBS/UPS)	1	EACH	703.2.14	
VIDEO DETECTION DEVICE & HARDWARE		EACH	703.3.1	
RADAR DETECTION DEVICE & HARDWARE	SEE TABLE	EACH	703.3.2	
TRAFFIC SIGNAL HEAD	Chart A	EACH	703.4.1	
SIGNAL HEAD MOUNTING BRACKET	Chart A	EACH	703.4.2	
RETROREFLECTIVE BACKPLATE	Chart A	EACH	703.4.3	
VEHICLE TRAFFIC SIGNAL LED MODULES	46	EACH	703.4.4	
PEDESTRIAN TRAFFIC SIGNAL LED MODULES	8	EACH	703.4.5	
APS PUSHBUTTON SYSTEM & SIGN (R10-3E, 9"x15")	8	EACH	703.4.6	
TRAFFIC SIGNAL POLE	Chart B	EACH	703.5.1	
TRAFFIC SIGNAL PEDESTAL (ALUMINUM)	3	EACH	703.5.2	
ADA PUSHBUTTON STATION (ALUMINUM)	1	EACH	703.5.3	
SERVICE BOX	N/A	EACH	703.6	EXISTING SERVICE BOXES
LUMINAIRE ARM	3	EACH	703.7.1	
LED LUMINAIRE	3	EACH	703.7.2	POWER COMPANY PROVIDED & INSTALLED
PHOTOCELL	3	EACH	703.7.3	POWER COMPANY PROVIDED & INSTALLED
UNFUSED STREET LIGHT CONNECTOR KIT	3	EACH	703.7.4	
FUSED STREET LIGHT CONNECTOR KIT	3	EACH	703.7.5	
OVERHEAD STREET NAME SIGN	4	EACH	703.8.1	
R10-10 SIGN (30" X 36")		EACH	703.8.2	
R10-FYA SIGN (30" X 36")	4	EACH	703.8.2	
BLANK OUT SIGN (36" X 36")		EACH	703.8.3	
ENTRANCE HEAD		EACH	703.9.2	
SERVICE ENCLOSURE, 200 AMP.	1	EACH	703.9.3	
CIRCUIT BREAKER, TRAFFIC SIGNAL, 50 AMP.	1	EACH	703.9.4	
CIRCUIT BREAKER, LUMINAIRE, 15 AMP.	1	EACH	703.9.4	
SURGE ARRESTER CA 302R	1	EACH	703.9.5	
POWER SERVICE CONTROLLER CABINET	1	EACH	703.9.6	
GROUND ROD & CLAMP	10	EACH	703.10	
SERVICE WIRE NO. 6 AWG 1/C	30	LIN FT	703.11.1	
LIGHTING DISTRIBUTION WIRE NO. 8 AWG 1/C	-	LIN FT	703.11.2	
POLE & BRACKET WIRE NO. 10 AWG 1/C	-	LIN FT	703.11.3	
GROUND WIRE NO. 6 AWG 1/C BARE SOLID	910	LIN FT	703.11.4	
TRACER WIRE NO. 12 AWG (BLUE)	600	LIN FT	703.11.5	
TRACER WIRE CONNECTOR	1	EACH	703.11.6	
MULTI-CONDUCTOR CABLE NO. 14 AWG 5/C	75	LIN FT	703.11.7	
MULTI-CONDUCTOR CABLE NO. 14 AWG 7/C	4,200	LIN FT	703.11.7	
DETECTION CABLE		LIN FT	703.11.9	
PRE-FORMED LOOP		EACH	703.11.10	
ETHERNET CABLE (CAT6)		LIN FT	703.11.11	
CONDUIT, 2" & FITTINGS	120	LIN FT	703.12	
CONDUIT, 3" & FITTINGS	200	LIN FT	703.12	
CONDUIT, ___ & FITTINGS		LIN FT	703.12	

- NOTES:
- QUANTITIES SHOWN ARE FOR 29TH STREET N AND GREENWICH ROAD SIGNAL.
 - REFER TO CITY OF WICHITA PART 700 TRAFFIC SIGNALIZATION SPECIFICATIONS.
 - ALL TRAFFIC SIGNAL POLES SHALL BE PAINTED BLACK PER LATEST EDITION OF PART 700 SPECIFICATIONS. SIGNAL CABINET SHALL BE NATURAL ALUMINUM.
 - CONFLICT MONITOR SHALL BE A 2010 ECL-IP UNIT WITH ETHERNET PORT.
 - A SEPARATE DETECTION CARD SHALL BE USED FOR EACH INTERSECTION LEG. THE DETECTION SYSTEM INCLUDES DETECTOR UNIT, PROCESSOR, CARD, AND INCIDENTAL ITEMS NECESSARY FOR THE SUCCESSFUL OPERATION OF THE DETECTION SYSTEM.
 - AUXILLARY OUTPUT FILE SHALL BE FULLY WIRED AND FUNCTIONAL AT THE TIME OF SIGNAL TURN-ON.
 - POWER STRIP TO BE TRIPP LITE POWER STRIP RACKMOUNT METAL 120V 5-15R 12 OUTLET 15' CORD, 19"RACKMOUNT 1U, NEMA 5-15P - 12 NEMA 5-15R - 15FT, OR APPROVED EQUAL. POWER STRIP IS TO BE MOUNTED IN REAR OF CABINET AT THE TOP OF THE RACK, AND PLUGGED INTO THE 2- CONTROLLER PLUG IN PDA2.

BILL OF MATERIALS (contd.)

RADAR DETECTION DEVICE & HARDWARE
-Quantities for Information Only-

Item	Model	Quantity	Unit
STOP BAR DETECTION UNIT	WX-SS-225	4	EACH
ADVANCE DETECTION UNIT	WX-SS-200V	2	EACH
DETECTION UNIT HARNESS	WX-SS-704-080	6	EACH
DETECTION UNIT BRACKET	WX-SS-611	6	EACH
CABINET INTERFACE DEVICE	CLICK 600	2	EACH
CONTACT CLOSURE	CLICK 114	6	EACH
DETECTION UNIT CABLING	STOP BAR UNIT(S)	As Needed	LIN FT
	ADVANCE UNIT(S)	As Needed	LIN FT

BID ITEM

Item	Quantity	Unit
Traffic Signal	LSUM	LSUM
Traffic Signal Controller	1	EACH
Detection System	LSUM	LSUM
Traffic Control	LSUM	LSUM
Site Clearing	LSUM	LSUM
Site Restoration	LSUM	LSUM
Tree Removed, Small	1	EACH

TRAFFIC SIGNAL CONTROLLER ITEM INCLUDES THE UNIT COST FOR PERMANENT CONTROLLER ONLY. COST FOR INSTALLATION, PROGRAMMING, ETC. SHALL BE INCLUDED IN THE "TRAFFIC SIGNAL" QUANTITY.

CONTROLLERS FOR TEMPORARY SIGNAL(S) IS SUBSIDIARY TO THE BID ITEM "TEMPORARY TRAFFIC SIGNAL".

FOR MULTIPLE PROJECT INTERSECTIONS, QUANTITIES SHOULD BID SEPARATELY FOR EACH SIGNALIZED INTERSECTION (EXCLUDING CONTROLLERS).

THE TRAFFIC SIGNAL SYSTEM SHALL BE COMPLETE AND THE CONTRACTOR SHALL FURNISH AND INSTALL ALL EQUIPMENT AND MATERIALS NECESSARY FOR THE SATISFACTORY OPERATION OF ELECTRICAL APPARATUS AND FOR COMPLETE OPERATION OF THE TRAFFIC SIGNAL SYSTEM WHETHER SPECIFICALLY MENTIONED OR NOT.

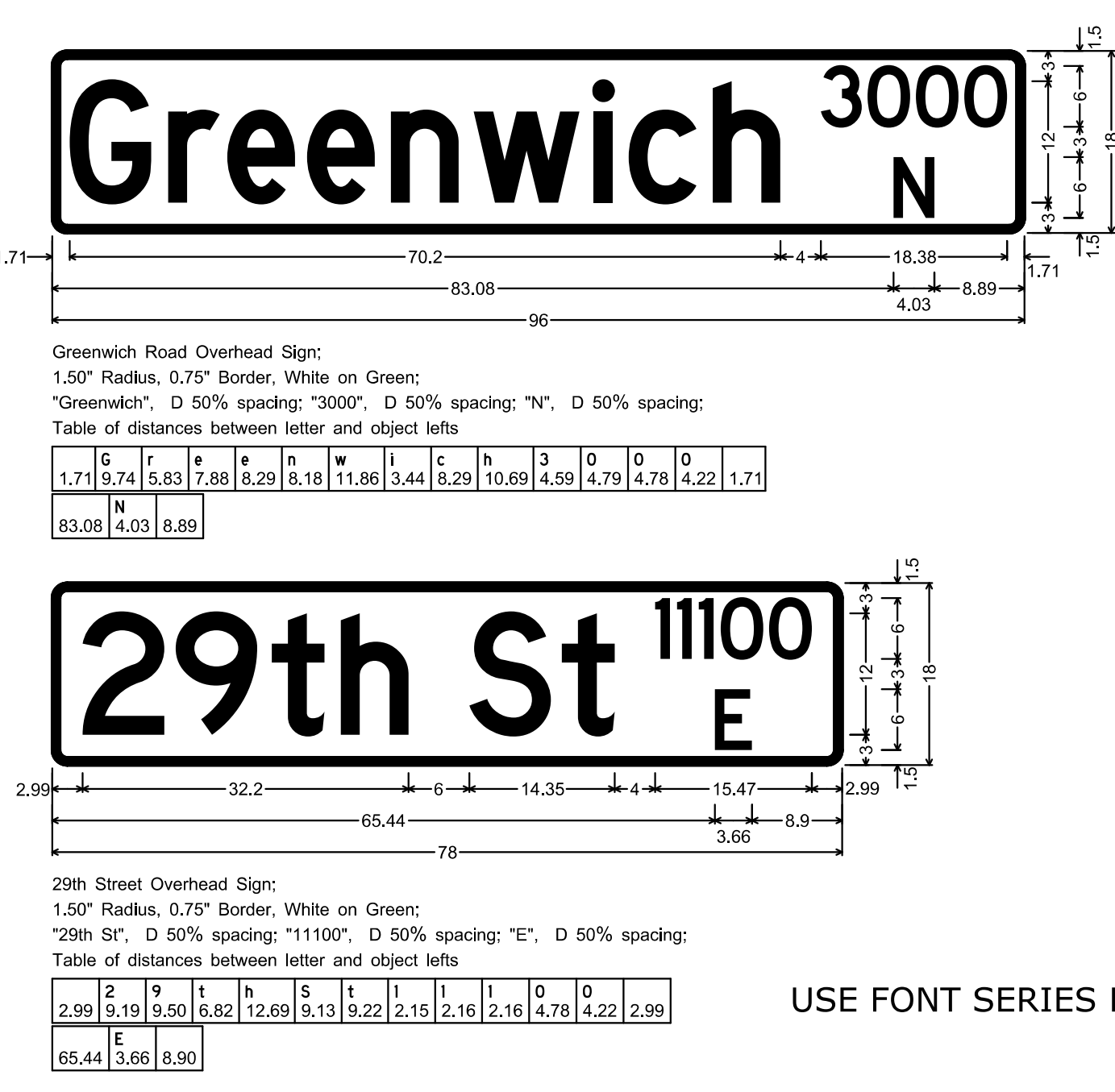

USE FONT SERIES D. SHEETING SHALL BE ASTM TYPE XI SHEETING. SEE SPECIFICATION 703.8

TRAFFIC SIGNAL QUANTITY SHEET

TRAFFIC ENGINEER APP'D 01/27/22
MIKE ARMOUR, P.E.

PROJECT NUMBER	ORG NUMBER	DATE
472-085773		12/20/2022

CITY ENGINEER'S OFFICE		SHEET
CITY HALL - SEVENTH FLOOR 455 NORTH MAIN STREET WICHITA, KANSAS 67202-1620 (316) 268-4501		5
		TR-102

PUBLIC WORKS & UTILITIES ENGINEERING DIVISION