

NOTE TO DESIGNER: Mast arm length shall be a minimum of 2 feet longer than last signal head. See "Signal Pole Data and Specification" for standard mast arm lengths and luminaire heights.

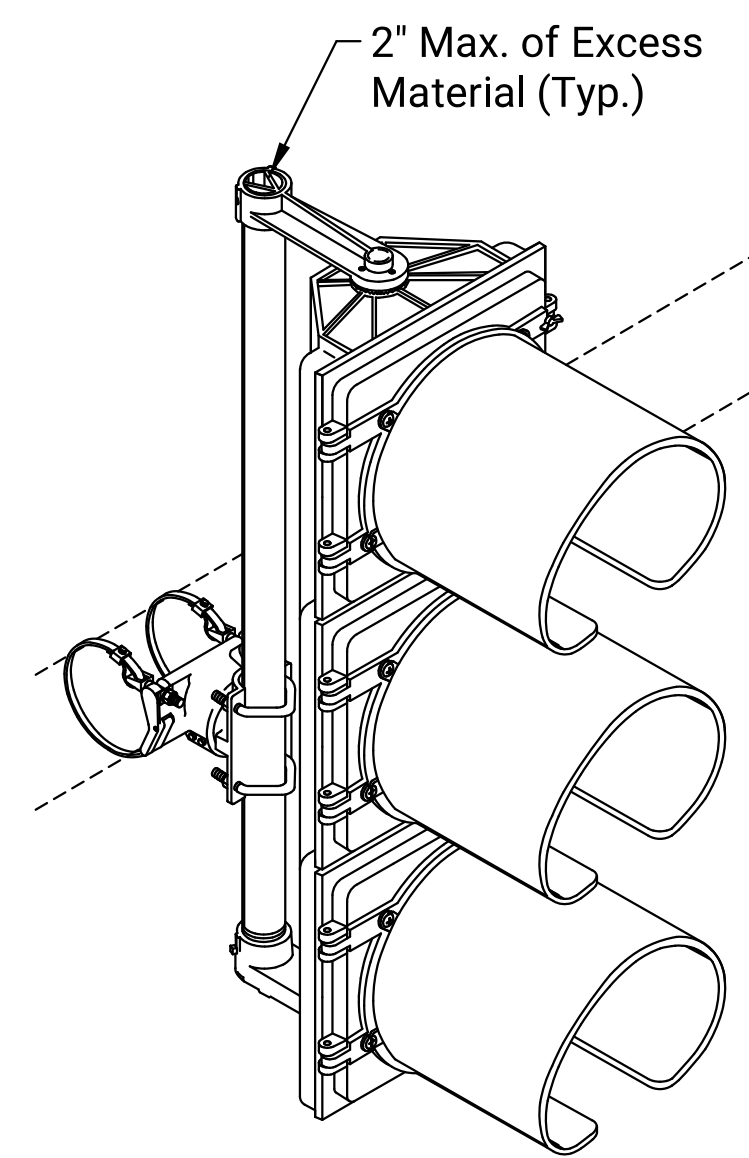

RIGID SIGNAL MOUNTING DETAIL

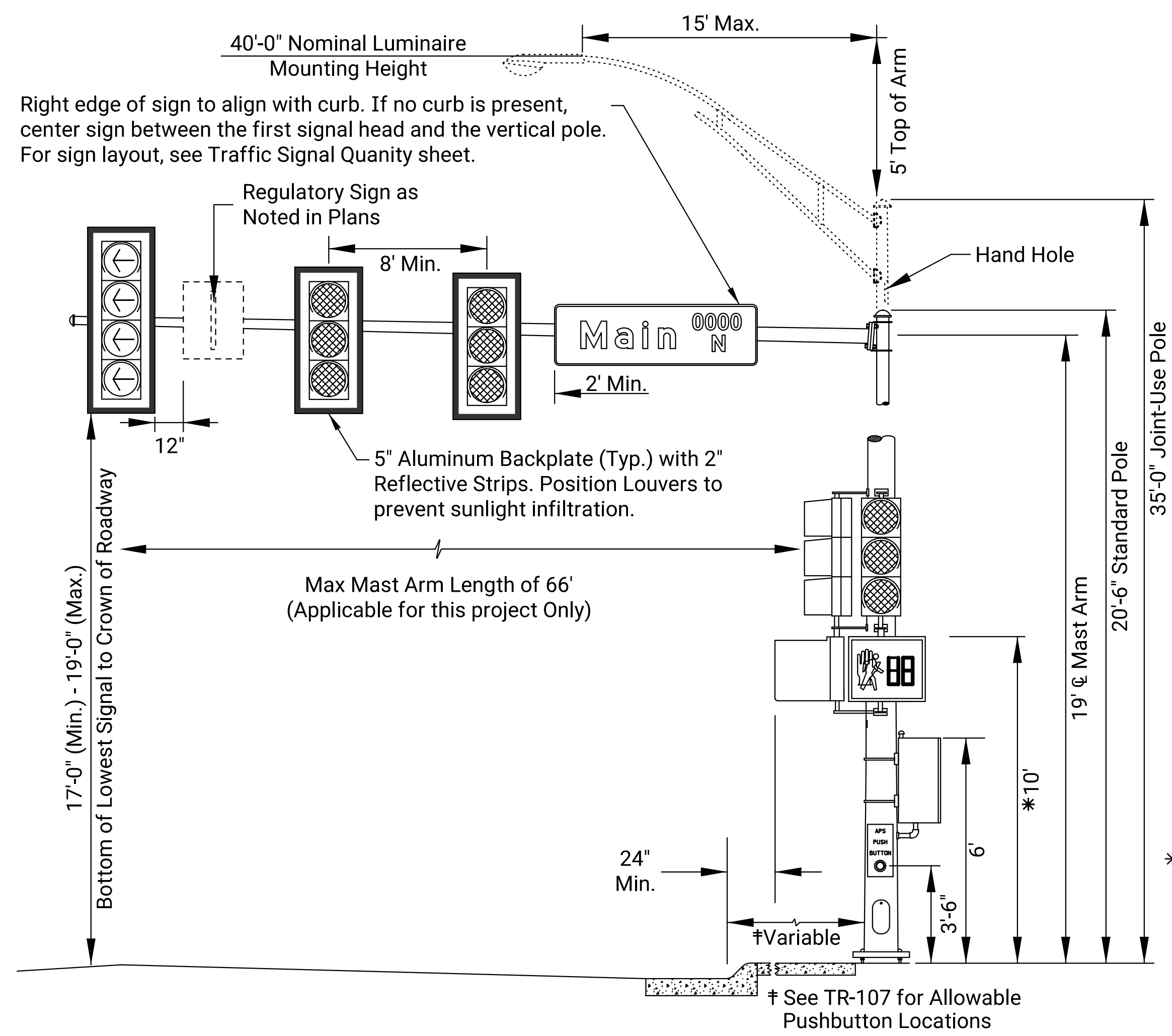
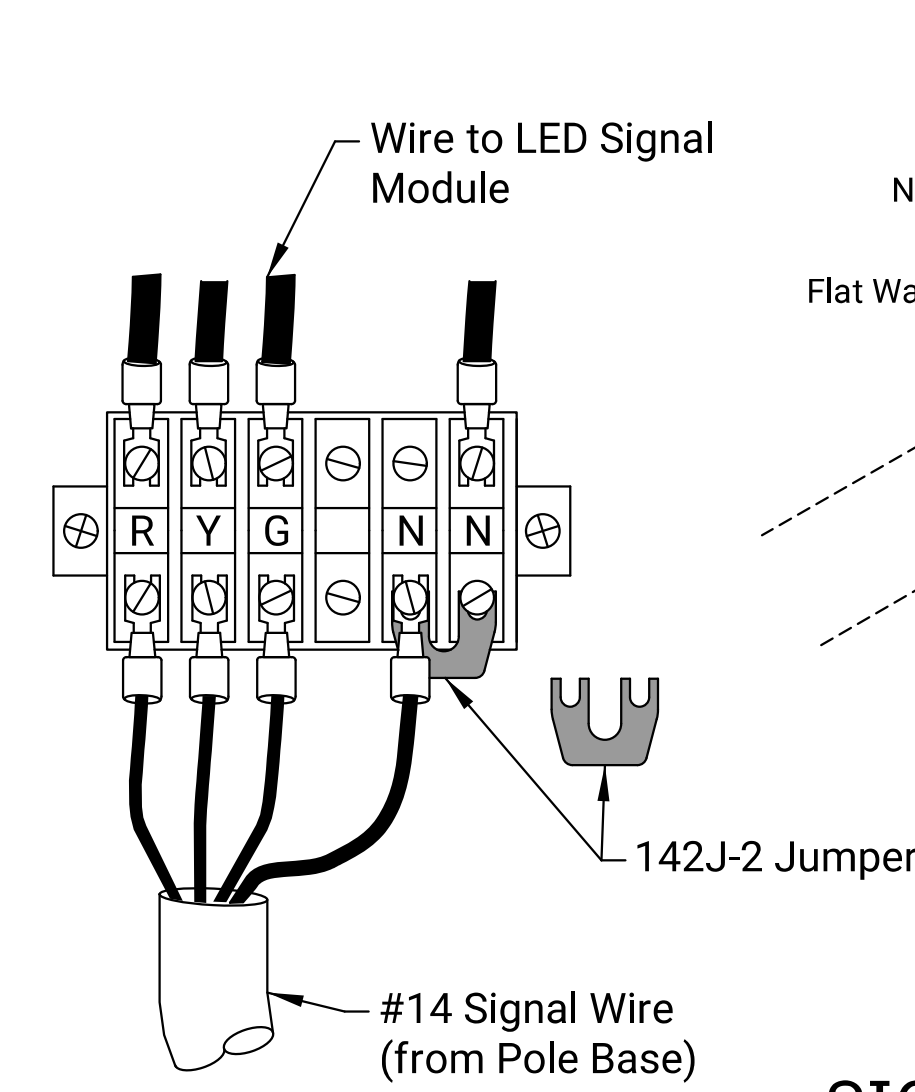

SIGNAL HEAD JUMPER DETAIL
Example for 3-Section Head Shown

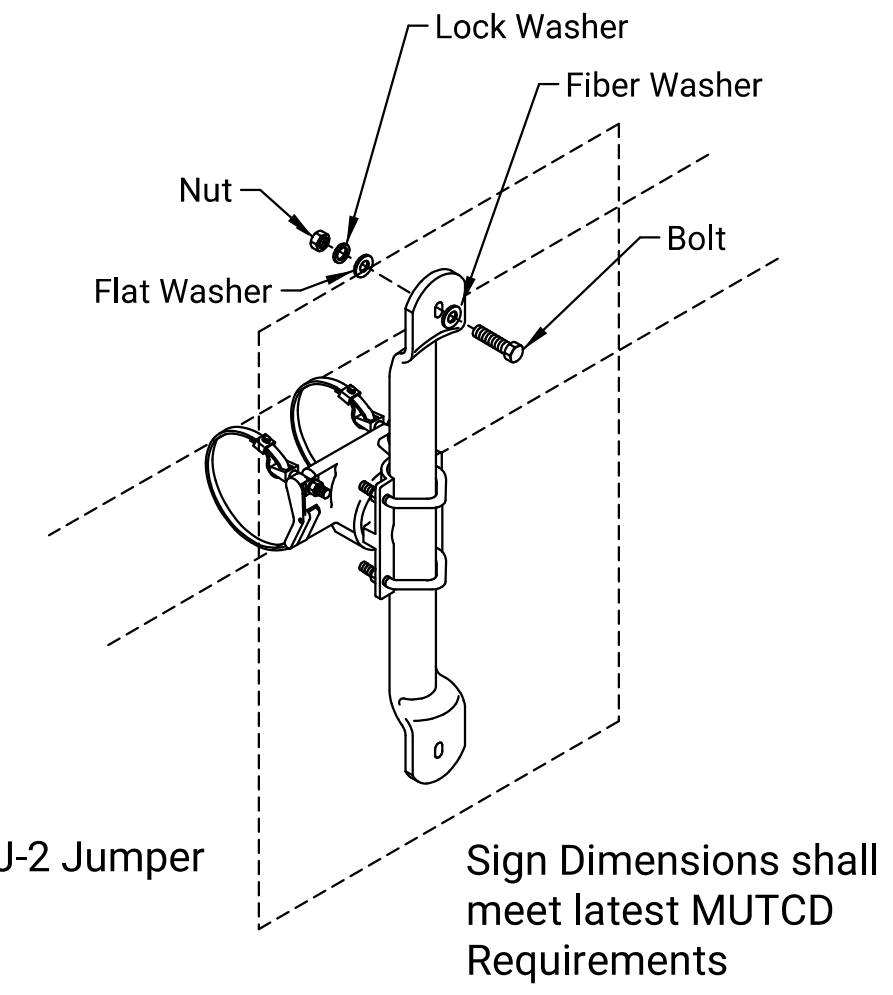

SIGN MOUNTING BRACKET DETAIL
SIGNS OVER 18" TALL (R10 SERIES)

* NOTE: Pedestrian signal heads shall be mounted so the top of signal head is at 10' above sidewalk level. Bottom of pedestrian head shall be 7' minimum from sidewalk level.

- NOTE:
1. USE ANTI-SEIZE COMPOUND ON ALL THREADS.
 2. GROUND RODS TO BE POSITIONED AND SHOWN TO INSPECTOR BEFORE POURING BASE.
 3. GROUND RODS FOR TRAFFIC SIGNAL MAST ARM POLES AND 342 CABINETS SHOULD BE 3/4" X 20'. TWO (2) 3/4" X 12' GROUND RODS MAY BE USED IN LIEU OF A SINGLE 20' GROUND ROD. ALL OTHER GROUND RODS SHALL BE 3/4" X 12'.
 4. CONCRETE SHALL MEET THE REQUIREMENTS OF GRADE 4.0 PER SPECIFICATIONS.
 5. CONSTRUCT SQUARE CONCRETE CAP AFTER POLE HAS BEEN ERECTED & PLUMBED. CHAMFER EDGE 1". MUST BE APPROVED BY ENGINEER BEFORE POURED.
 6. CONDUIT SHALL HAVE PLASTIC (OR METAL) BUSHING (ABOVE BASE) TO PREVENT CABLE CHAFING.
 7. RUBBER GROMMETS SHALL BE INSTALLED FOR WIRE ENTRANCE HOLES AT EACH PENETRATION LOCATION. HOLES MAY BE FIELD DRILLED AS PER MANUFACTURE SIZE AND PROCEDURES.
 8. HOLE(S) FOR WIRING SHOULD BE 7/8" MINIMUM DIAMETER AND MUST BE DEBURRED TO PREVENT DAMAGE. SPARE/EMPTY HOLES SHALL BE FILLED WITH TRADE-SIZE SMOOTH-FACE CONDUIT CLOSURE(S) OR AS DIRECTED BY CITY TRAFFIC SIGNAL MAINTENANCE.
 9. USE #6 BARE COPPER GROUND CONDUCTOR FROM CLAMP TO GROUND BOLT IN ACCESS HOLE.
 10. IN THE EVENT SOUND BEDROCK IS ENCOUNTERED AT A DEPTH LESS THAN STANDARD, CONTRACTOR SHALL NOT PROCEED WITHOUT ENGINEER APPROVAL OF SOCKET DEPTH.
 11. IT MAY BE NECESSARY TO USE A CONCRETE FORM/SONOTUBE FOR THE SIGNAL AND PEDESTRIAN POLE BASES WHERE PREVIOUS EXCAVATION MAY HAVE OCCURRED OR SANDY SOILS. IT IS EXPECTED THAT THE SIGNAL AND PEDESTRIAN POLES' LOCATIONS WILL NOT BE CHANGED AND IT IS UP TO THE CONTRACTOR TO ACCOUNT FOR CONCRETE FORMS WITHIN THEIR BID IF THEY ARE NEEDED FOR POSSIBLE UNSTABLE SOIL CONDITIONS.
 12. SEE TRAFFIC SIGNAL FOUNDATION DETAILS SHEET FOR ADDITIONAL DETAILS.

NO.	DATE	BY	APP'D
3			
2			
1			

REVISIONS



TRAFFIC SIGNAL INSTALLATION DETAIL SHEET		
TRAFFIC ENGINEER APP'D 01/27/22 MIKE ARMOUR, P.E.		
PROJECT NUMBER 472-085773	ORG NUMBER	DATE 12/20/2022
CITY ENGINEER'S OFFICE CITY HALL - SEVENTH FLOOR 455 NORTH MAIN STREET WICHITA, KANSAS 67202-1620 (316) 268-4501		SHEET 6 TR-105