

File: L:\2022\22T41020 - Bellechase 3rd Addition Phase 4\Drawings\C3DPAVING\SIERRA HILLS.dwg Last Save: 3/6/2023 11:22 AM Last saved by: MCarreteraPiedra
 Last plotted by: Carrera-Piedra, Mariela Plot Date: 3/7/2023 10:38 AM Plotter used: None

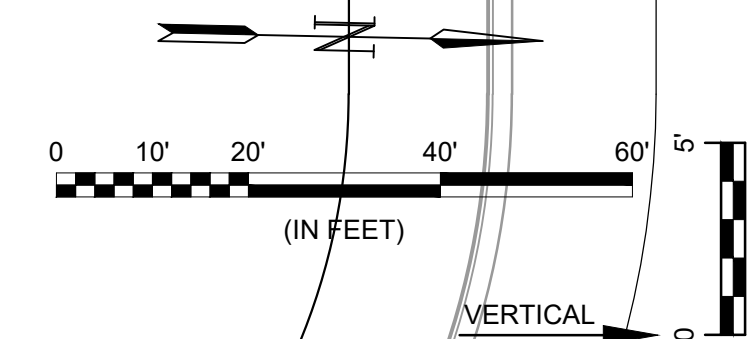
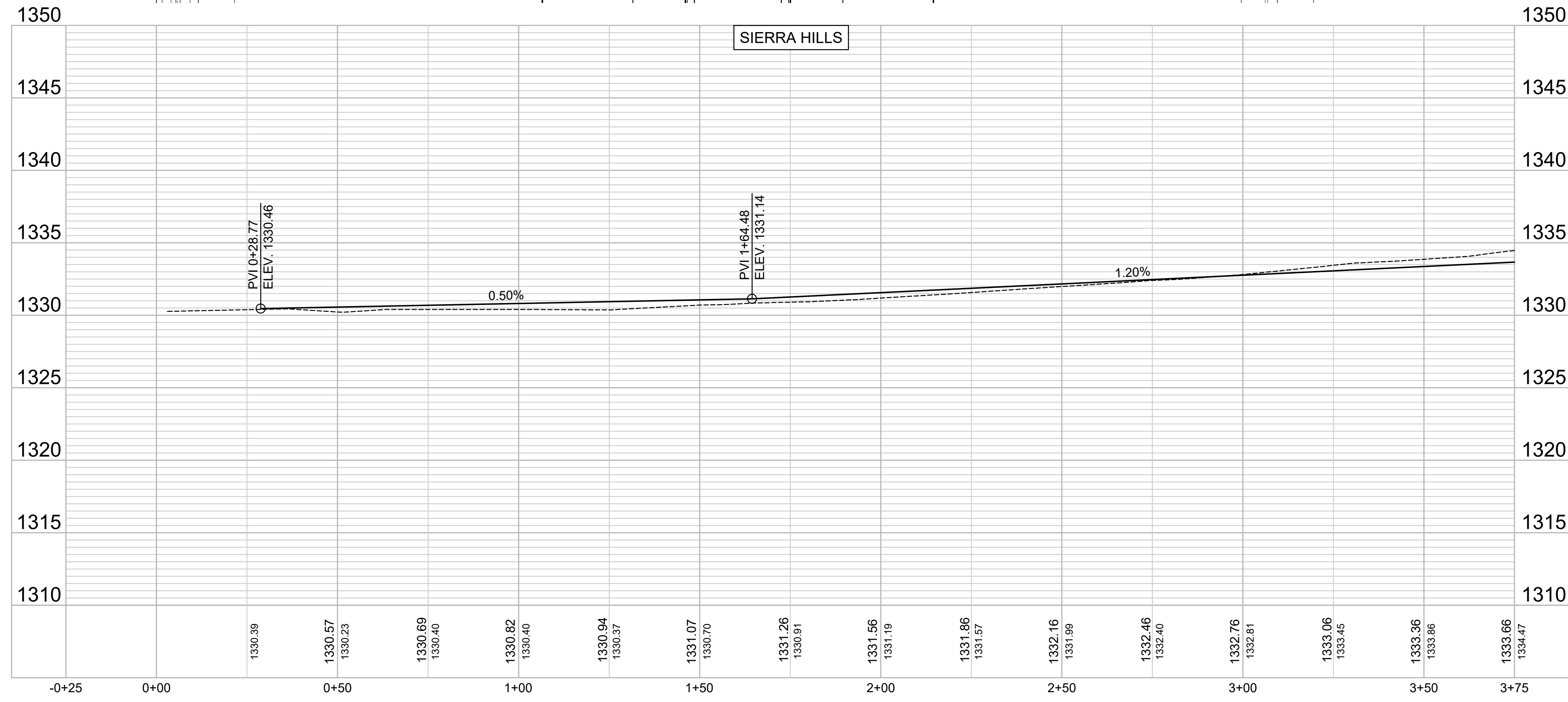
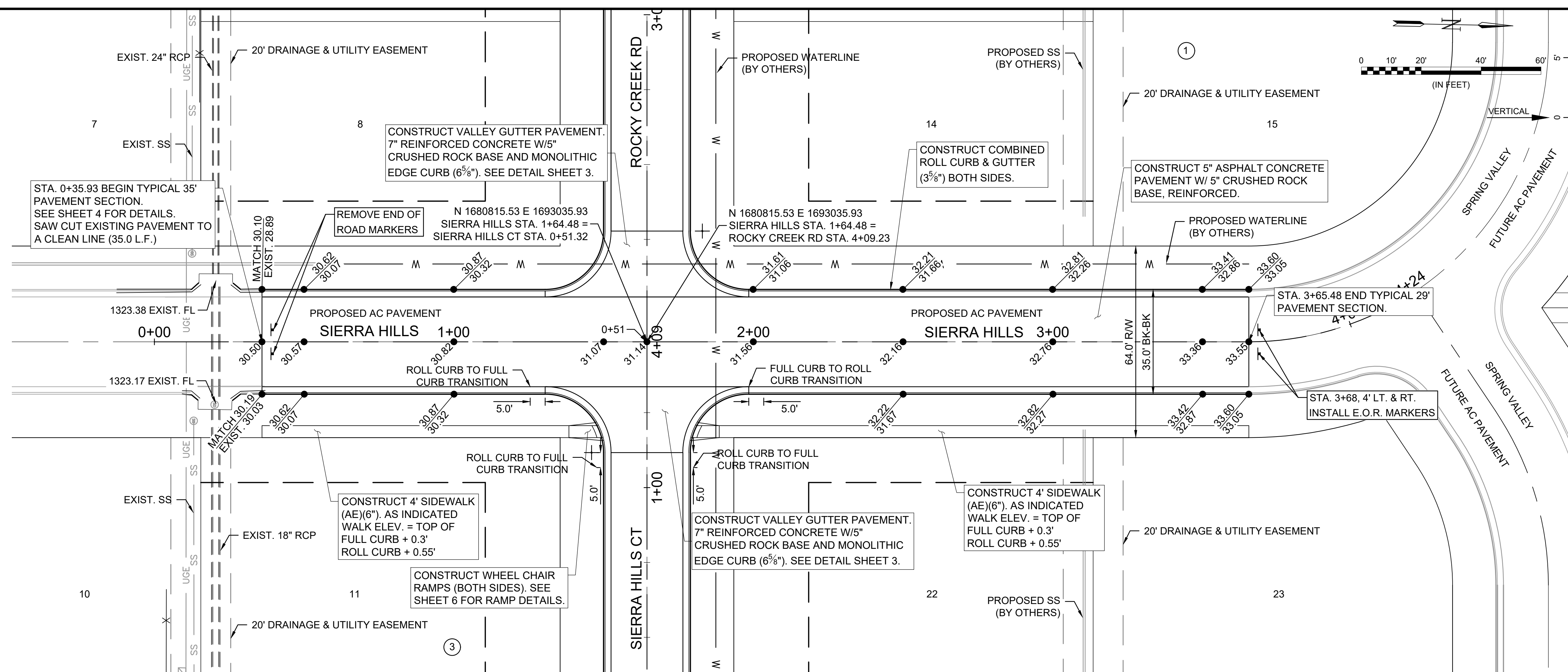

GARVER
 © 2022 GARVER, LLC
 THIS DOCUMENT, ALONG WITH THE IDEAS AND DESIGNS CONVEYED HEREIN, SHALL BE CONSIDERED INSTRUMENTS OF PROFESSIONAL SERVICE AND ARE PROPERTY OF GARVER, LLC. ANY USE, REPRODUCTION, OR DISTRIBUTION OF THIS DOCUMENT, ALONG WITH THE IDEAS AND DESIGN CONTAINED HEREIN, IS PROHIBITED UNLESS AUTHORIZED IN WRITING BY GARVER, LLC OR EXPLICITLY ALLOWED IN THE GOVERNING PROFESSIONAL SERVICES AGREEMENT FOR THIS WORK.

1995 Midfield Road
 Wichita, KS 67209
 (316) 264-8008

REV.	DATE	DESCRIPTION	BY

CITY OF WICHITA
 WICHITA, KANSAS
BELLECHASE THIRD ADDITION PHASE 4 PAVING

SIERRA HILLS
 JOB NO.: 22T41020
 DATE: MARCH 2023
 DESIGNED BY: EJJ
 DRAWN BY: MCP
 BAR IS ONE INCH ON ORIGINAL DRAWING
 IF NOT ONE INCH ON THIS SHEET, ADJUST SCALES ACCORDINGLY.
 DRAWING NUMBER
 SHEET NUMBER **7** OF **29**