

STATE	PROJECT NO.	YEAR	SHEET NO.	TOTAL SHEETS
KANSAS	472-2021-085750	2022	4	5

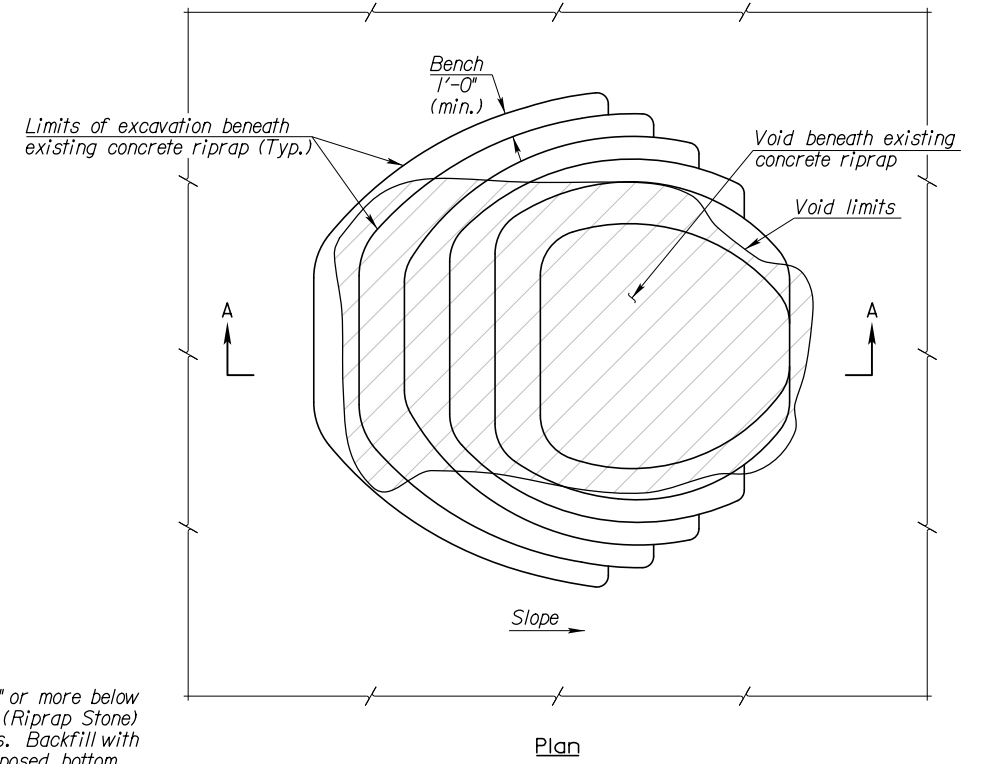

EXCAVATION: Any excavation required 2'-0" or more below the proposed bottom of Slope Protection (Riprap Stone) will be excavated as shown in the details. Backfill with (Type A) (MR-5-5) Compaction to the proposed bottom of Slope Protection (Riprap Stone).

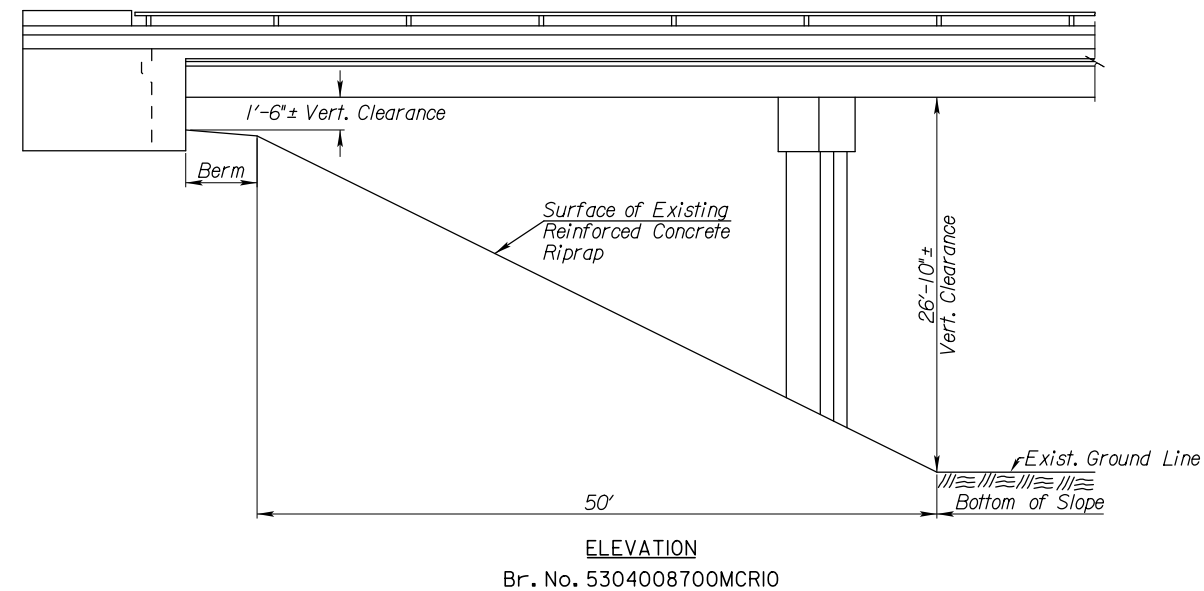
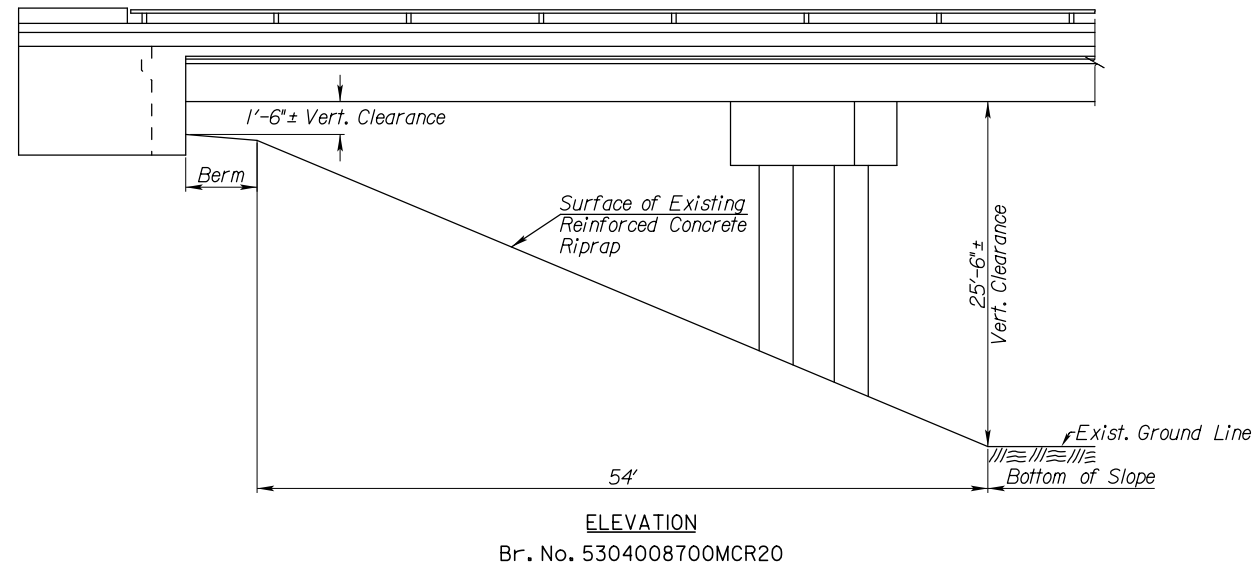
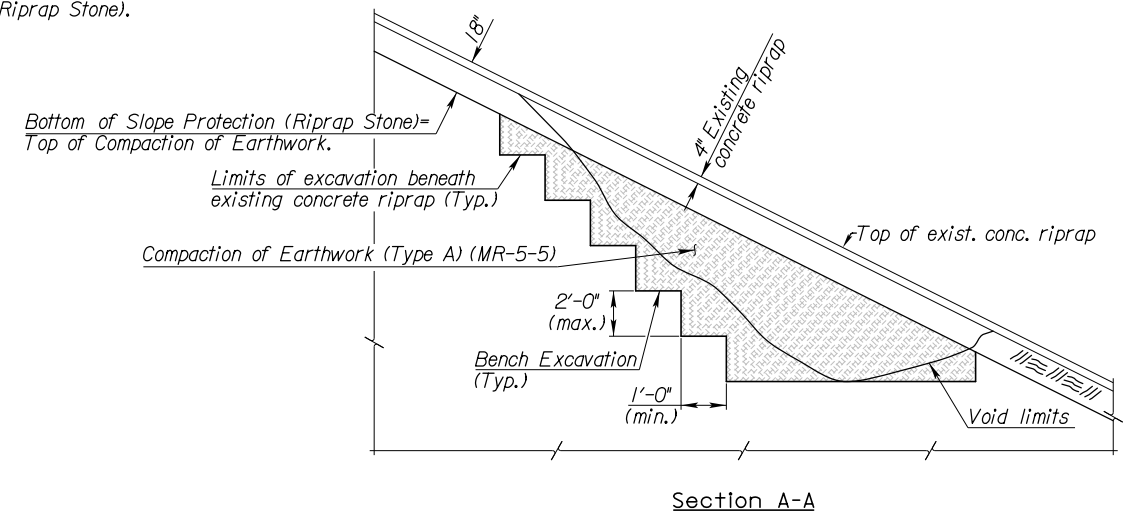

EXCAVATION AND COMPACTION OF EARTHWORK DETAILS

Plotted By: mike.thompson
File: Eisenhower Airport Parkway.dgn
Plot Date: 13-MAR-2023 15:17

3					
2					
1					
NO.	DATE	REVISIONS	BY	APP'D	
CITY OF WICHITA					
Br. No. 5304008700MCR10 (SB)					
Br. No. 5304008700MCR20 (NB)					
EXISTING VERTICAL CLEARANCES					
Eisenhower Airport Parkway					
PROJECT NO. 472-2021-085750			SEDGWICK COUNTY		
SHEET NO.	OF	SCALE	APP'D		
DESIGNED		DETAILED	QUANTITIES	CADD	
DESIGN CK.		DETAIL CK.	QUAN. CK.	CADD CK.	