

BENCHMARKS:
BM-1#:
 SQUARE CUT ON TOP OF CURB 119.3'± N.
 ± 6.4'± W. OF SE. COR., LOT 7, BLOCK 2,
 TURTLE RUN 3RD ADDITION.
 ELEV. = 1390.32 NAVD88

BM-2#:
 SQUARE CUT ON TOP OF CURB 118.4'± N.
 OF SE. COR., LOT 6, BLOCK 2, TURTLE
 RUN 2ND ADDITION.
 ELEV. = 1391.04 NAVD88

TOWNE PARC 10TH ADDITION

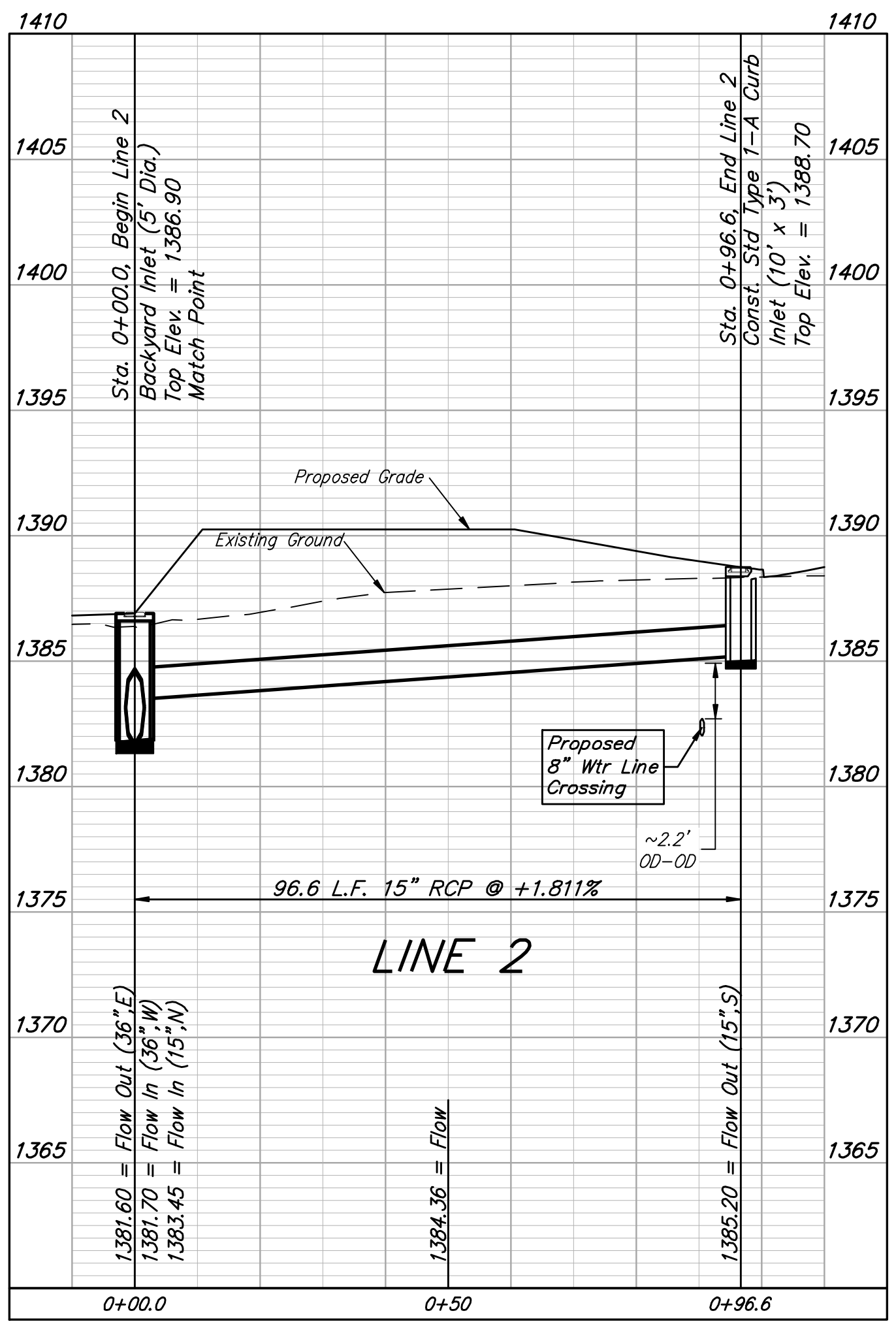
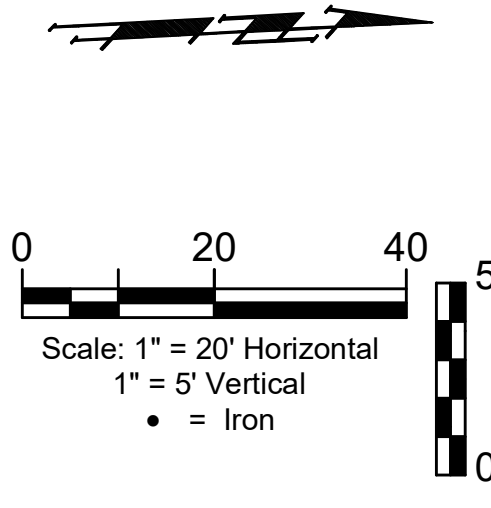
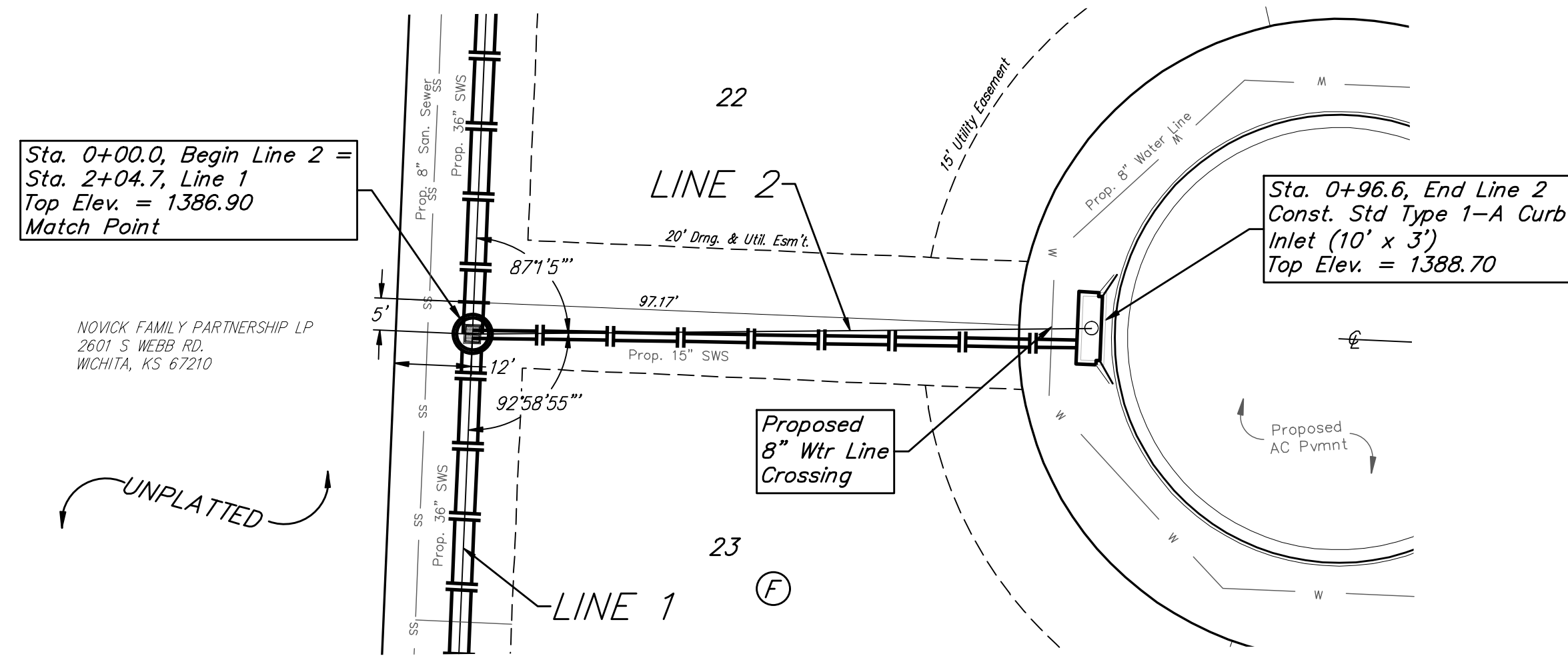

BAUGHMAN COMPANY

315 Ellis St.
 Wichita, KS 67211
 316-262-7271
 BaughmanCo.com

TOWNE PARC 10TH ADDITION

LINE 2

STORM WATER DRAIN IMPROVEMENTS

PROJECT NUMBER:
468-2023-085536

DESIGN: NBW DRAWN: JLD

DATE: June 12, 2023

SHEET **04** OF **37**

File: E:\Projects\Towne Parc 10th Addition_22-01-P743\Engineering\PHASE 1\SWD_22-11-E352\SWS-SWD.dwg