

4/20/23 3.34.10 PM

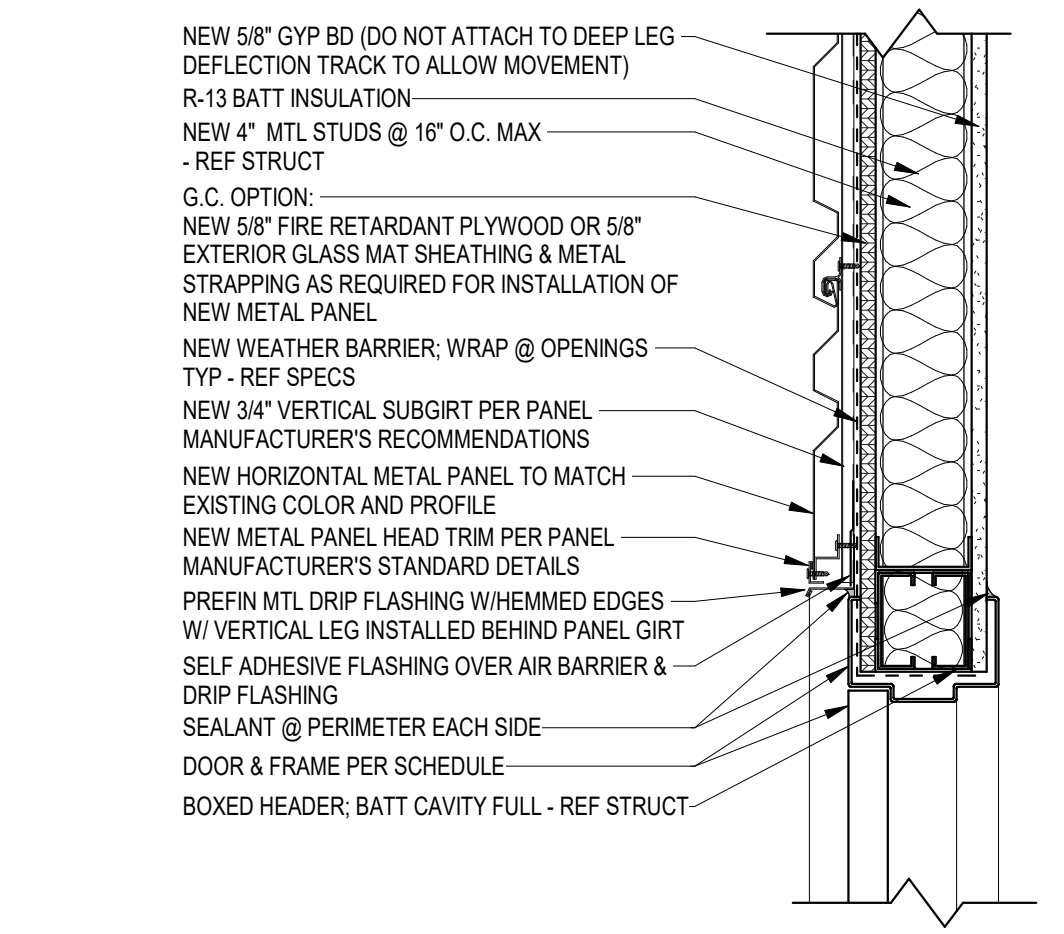

6 DOOR HEAD @ MTL PANEL
1 1/2" = 1'-0"

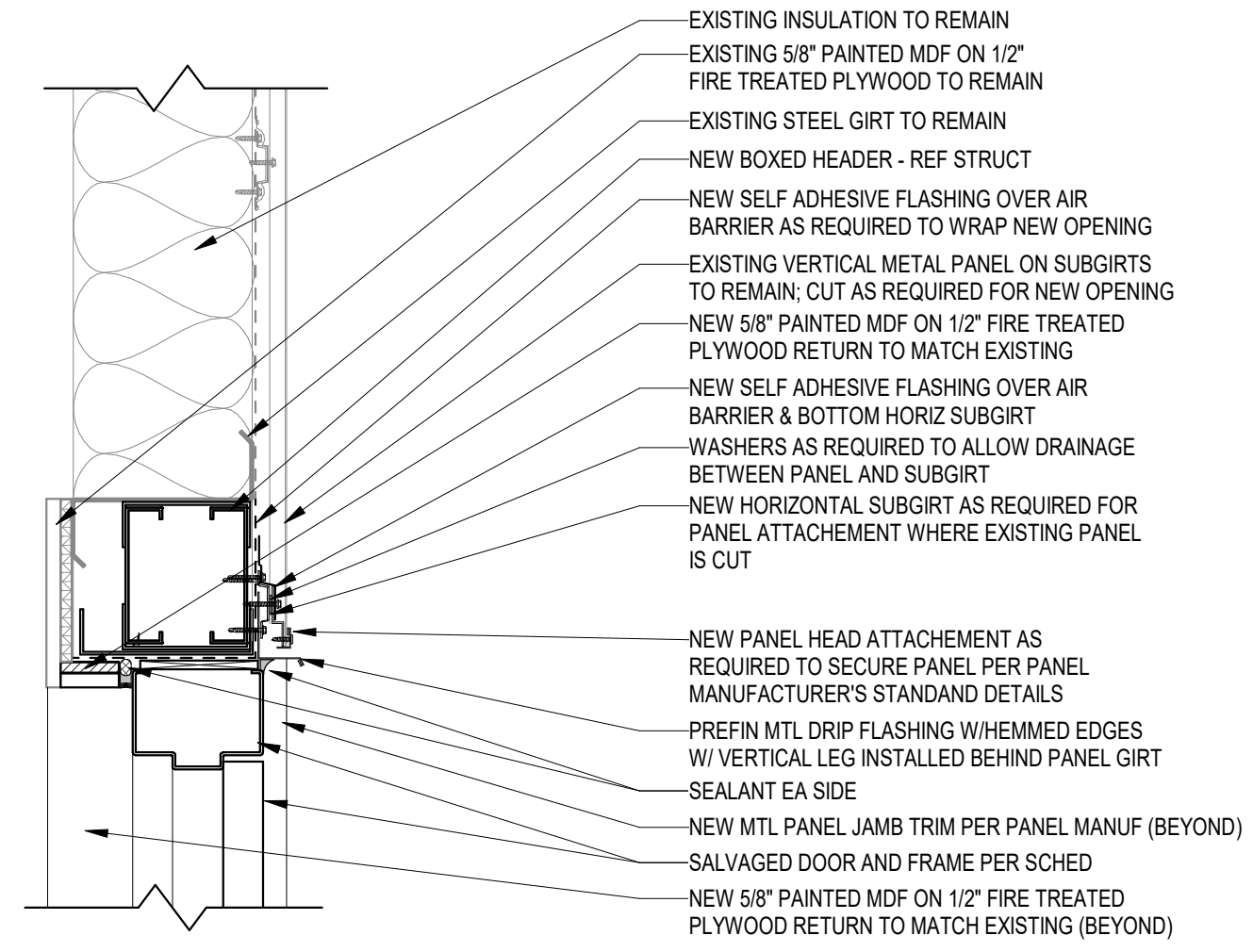

10 HM DOOR HEAD @ EXISTING PANEL
1 1/2" = 1'-0"

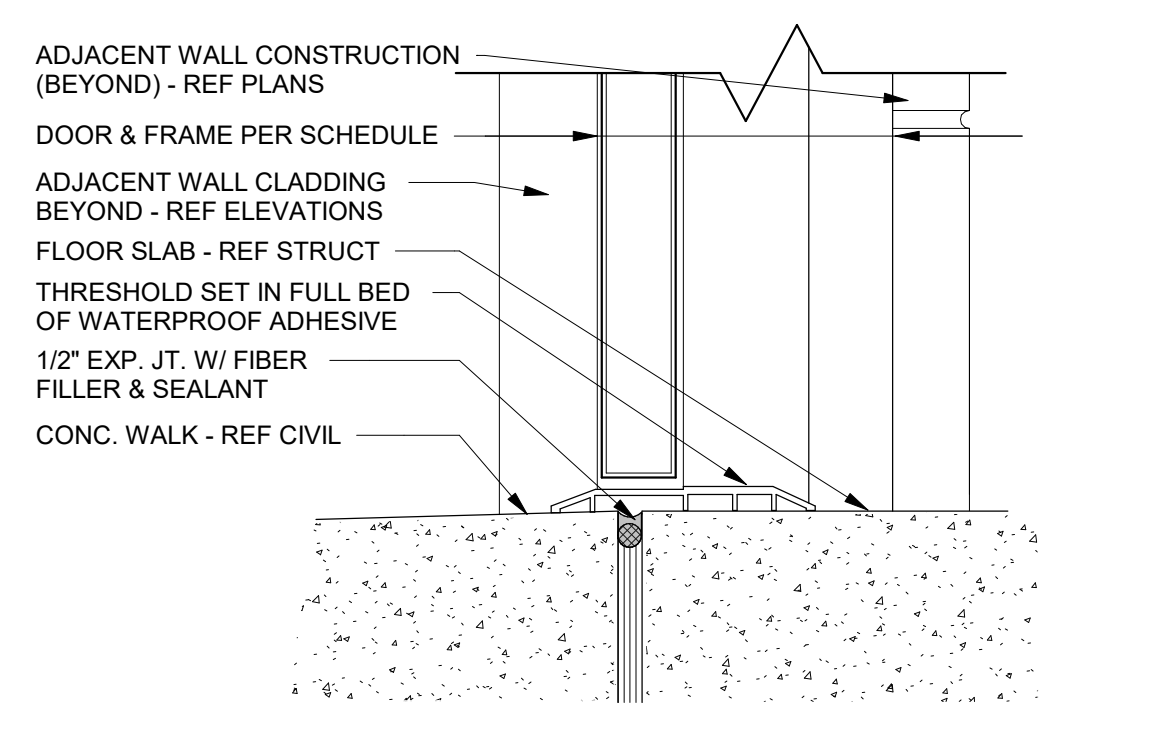

14 TYP THRESHOLD DETAIL
3" = 1'-0"

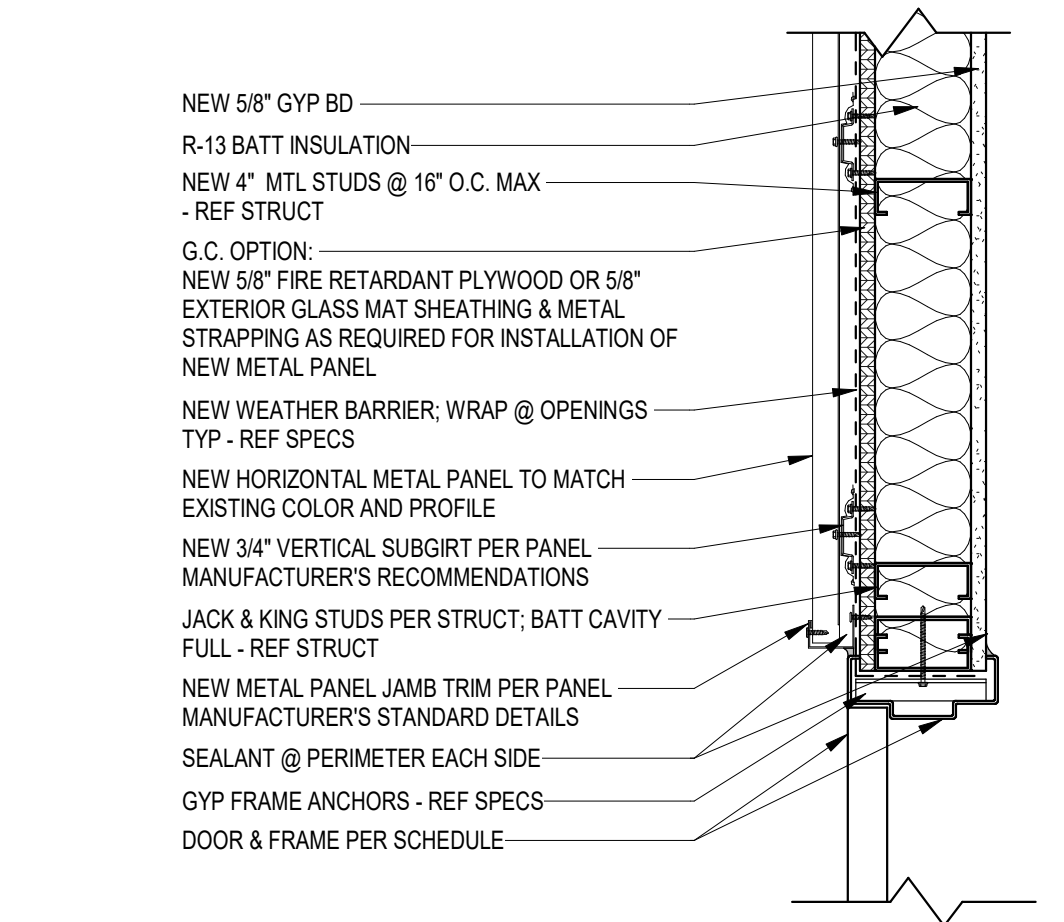

7 DOOR JAMB @ MTL PANEL
1 1/2" = 1'-0"

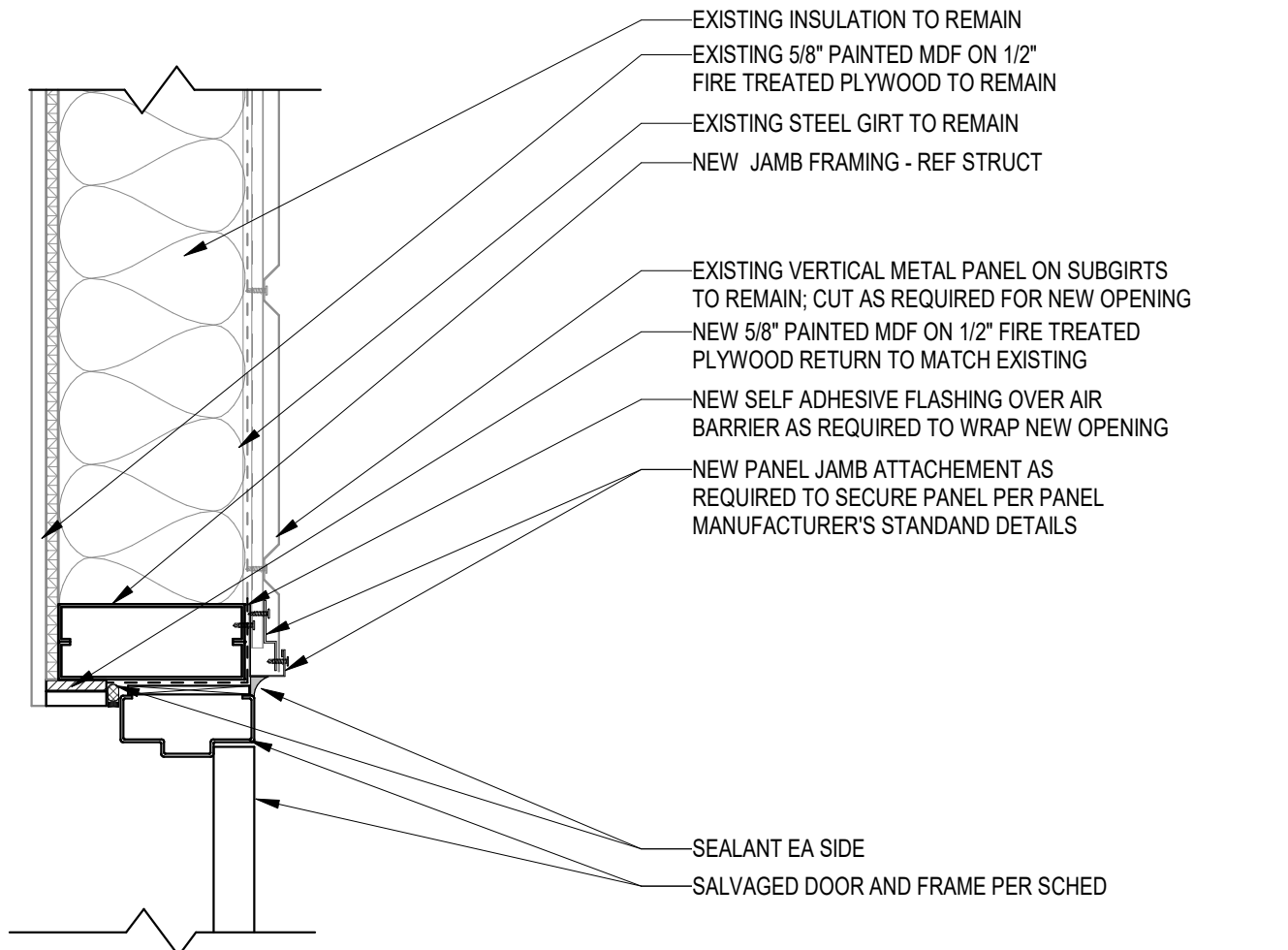

11 HM DOOR JAMB @ EXISTING PANEL
1 1/2" = 1'-0"

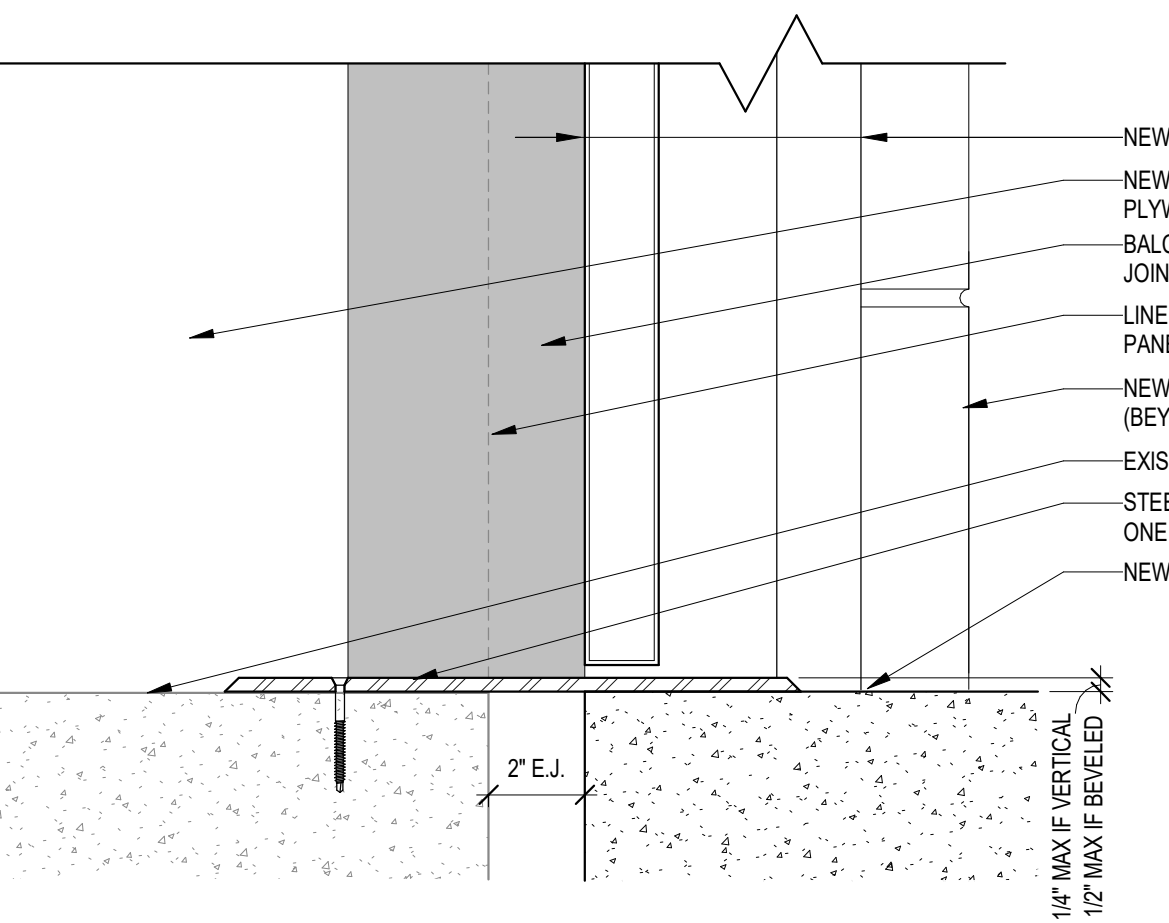

15 DOOR SILL @ EJ
3" = 1'-0"

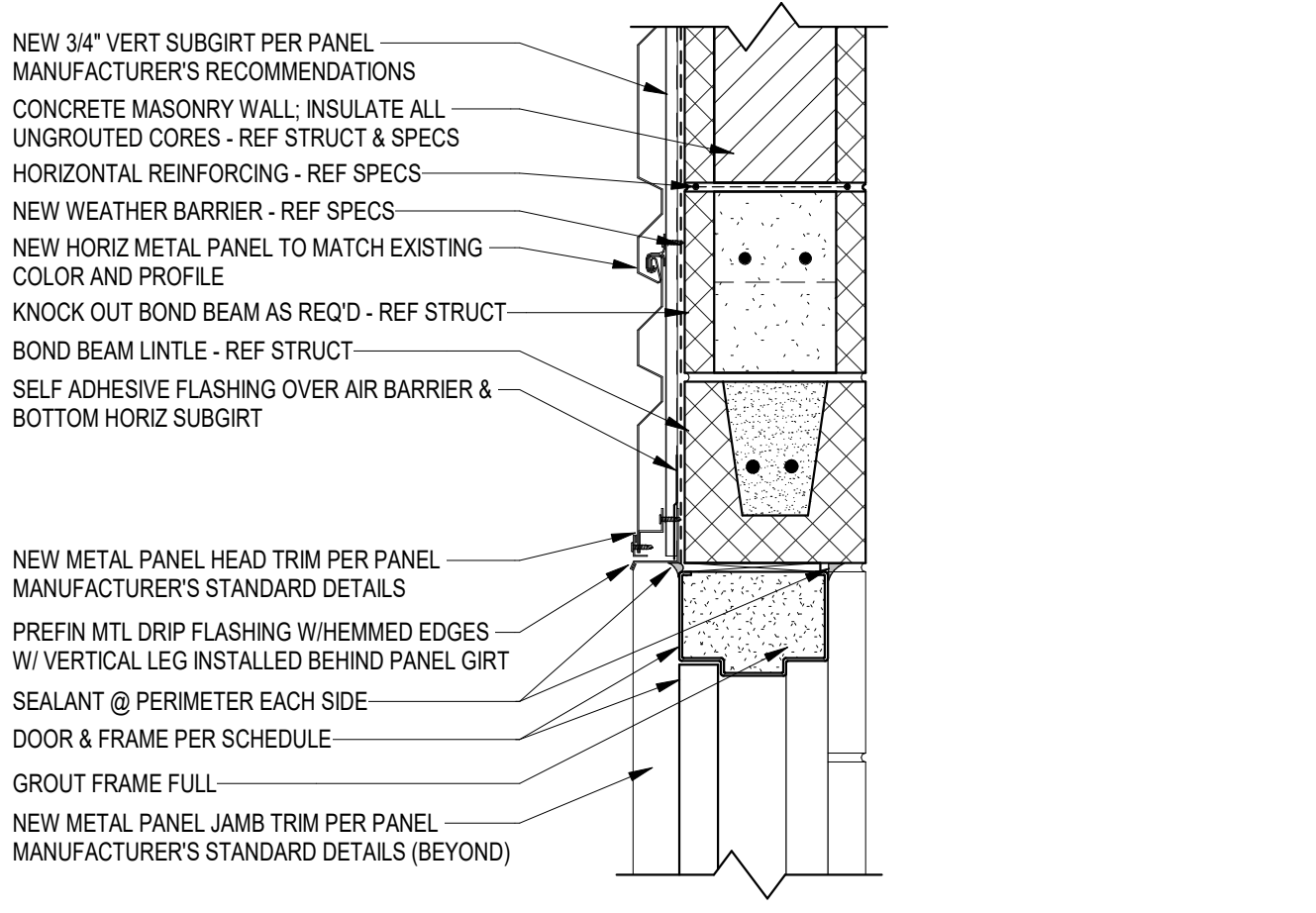

12 DOOR HEAD @ CMU & HORIZ MTL PANEL
1 1/2" = 1'-0"

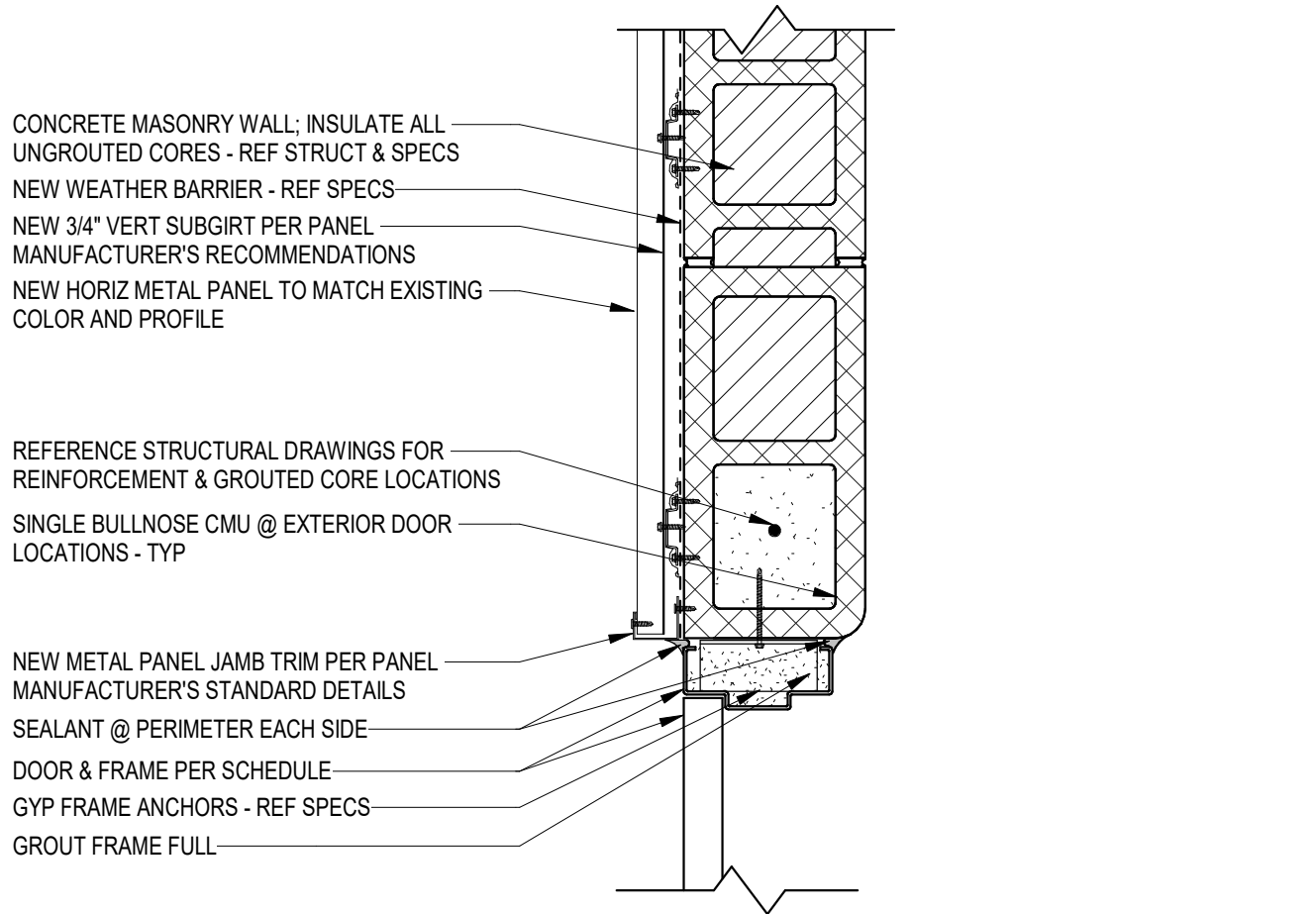

13 DOOR JAMB @ CMU & HORIZ MTL PANEL
1 1/2" = 1'-0"

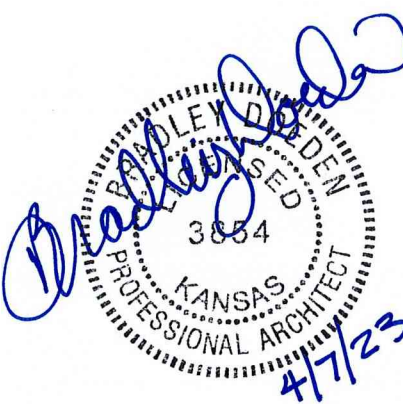

©2023 MKEC Engineering All Rights Reserved. www.mkec.com These drawings and their contents, including, but not limited to, all concepts, designs, & data are the exclusive property of MKEC Engineering (MKEC), and may not be used or reproduced in any way without the express consent of MKEC.

DOOR DETAILS

PROJECT NO.	01088R21003	
DATE	04-07-2023	
SCALE	AS NOTED	
DESIGNED	DRAWN	CHECKED
MH	SS	MH

0	ISSUED FOR CONSTRUCTION	04-07-23
NO.	REVISION	DATE

SHEET NO.
SA6.02



\\glvm\6464_glmv_mtl\Projects\01088R21003\04_Production\Published Model - 04-04-2023\01088R21003_A_Silver_Architects_Phase 9.rvt