

4/7/2023 9:58:55 AM

SEE ARCHITECTURAL DRAWINGS FOR RAILING DETAILS, TYPICAL

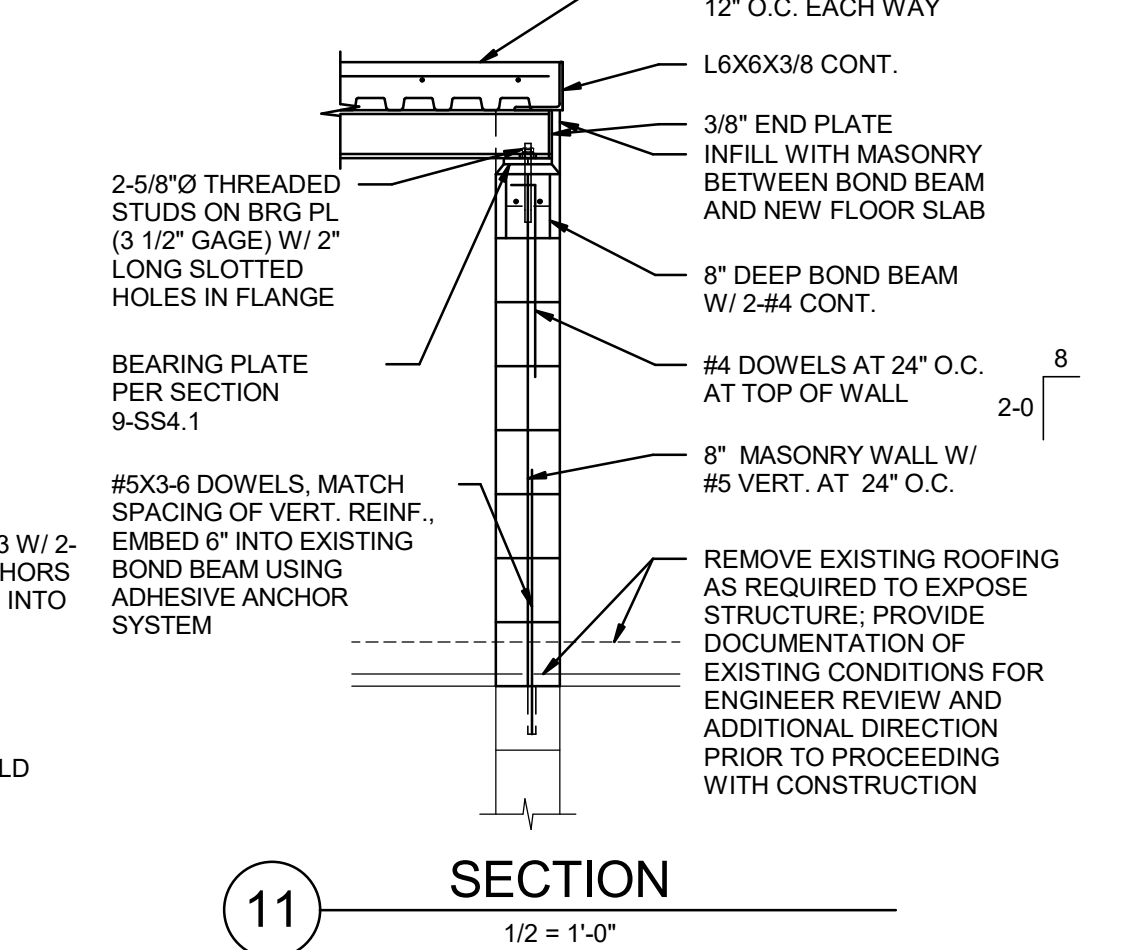
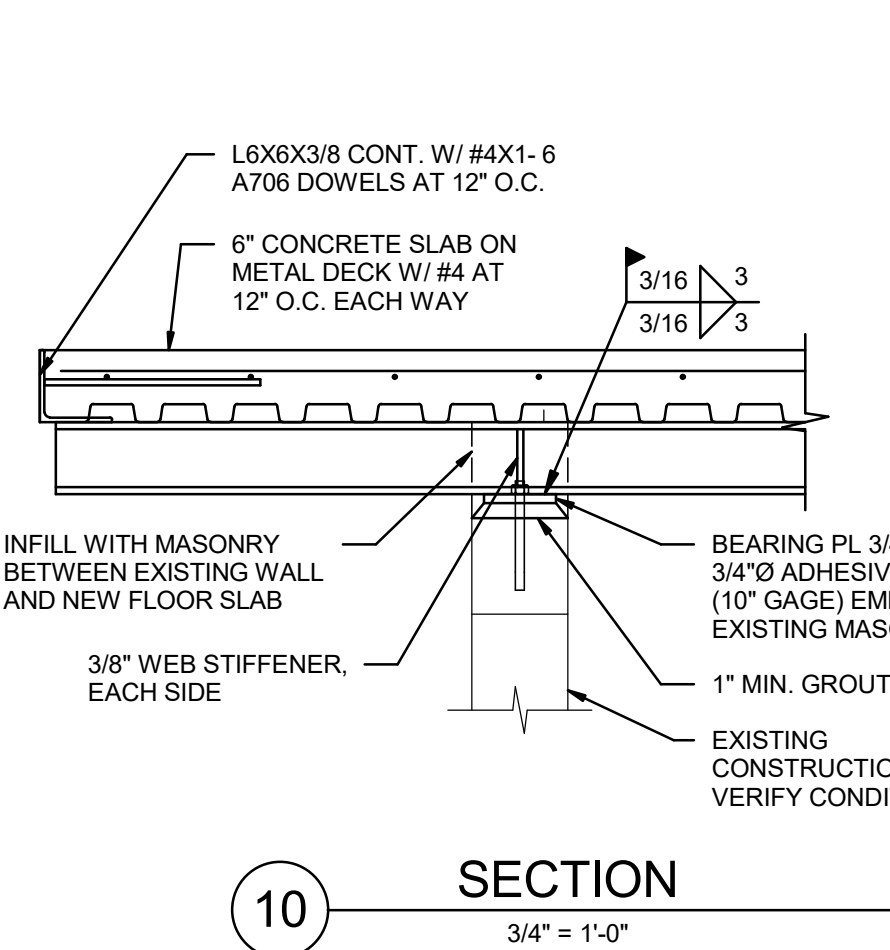
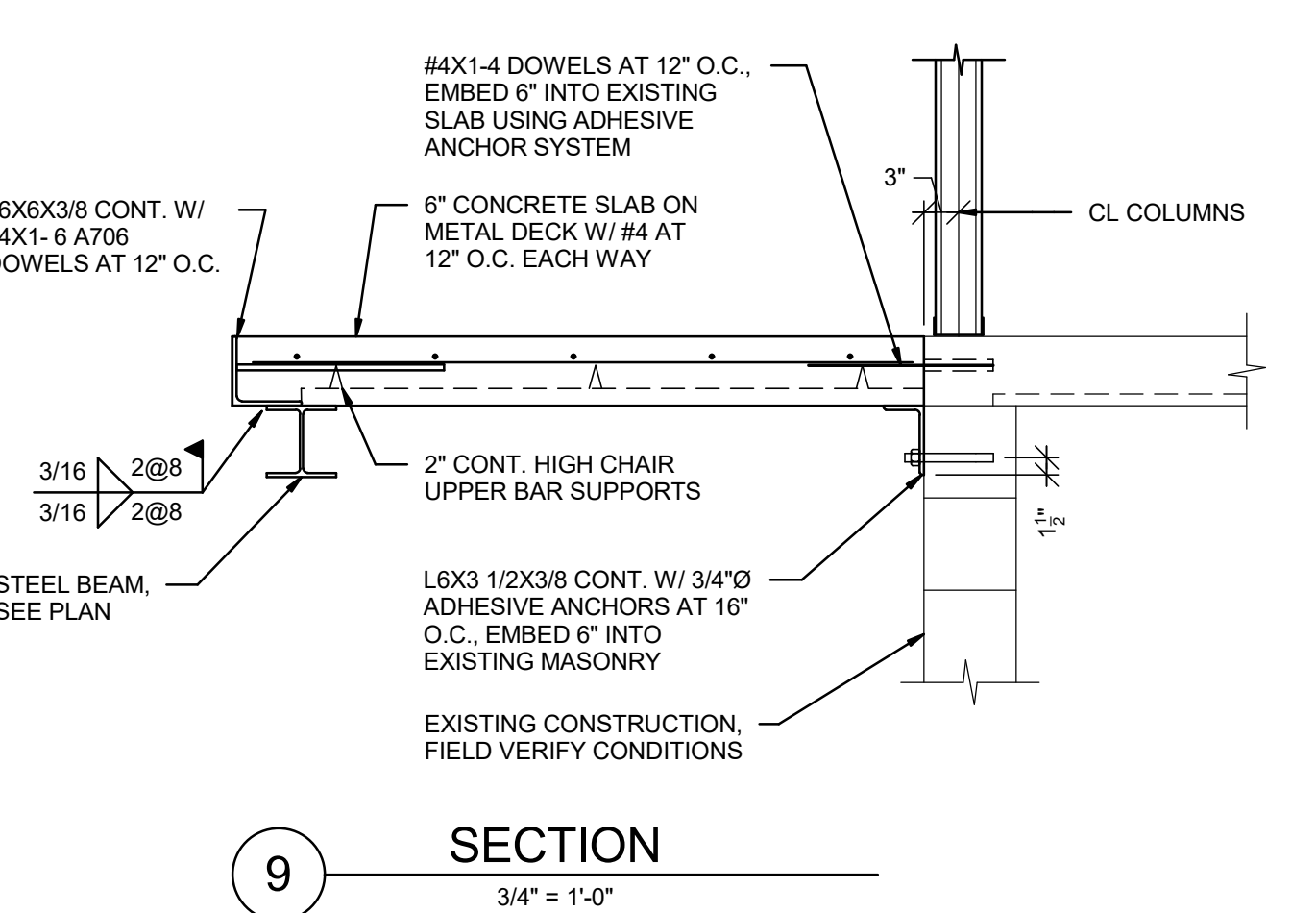
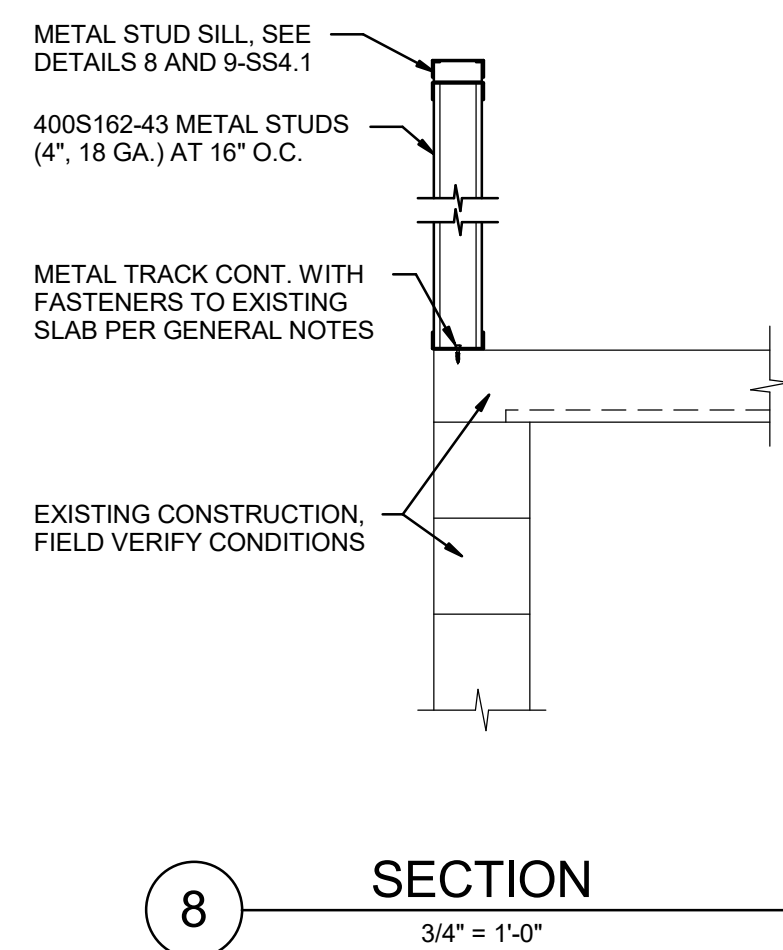
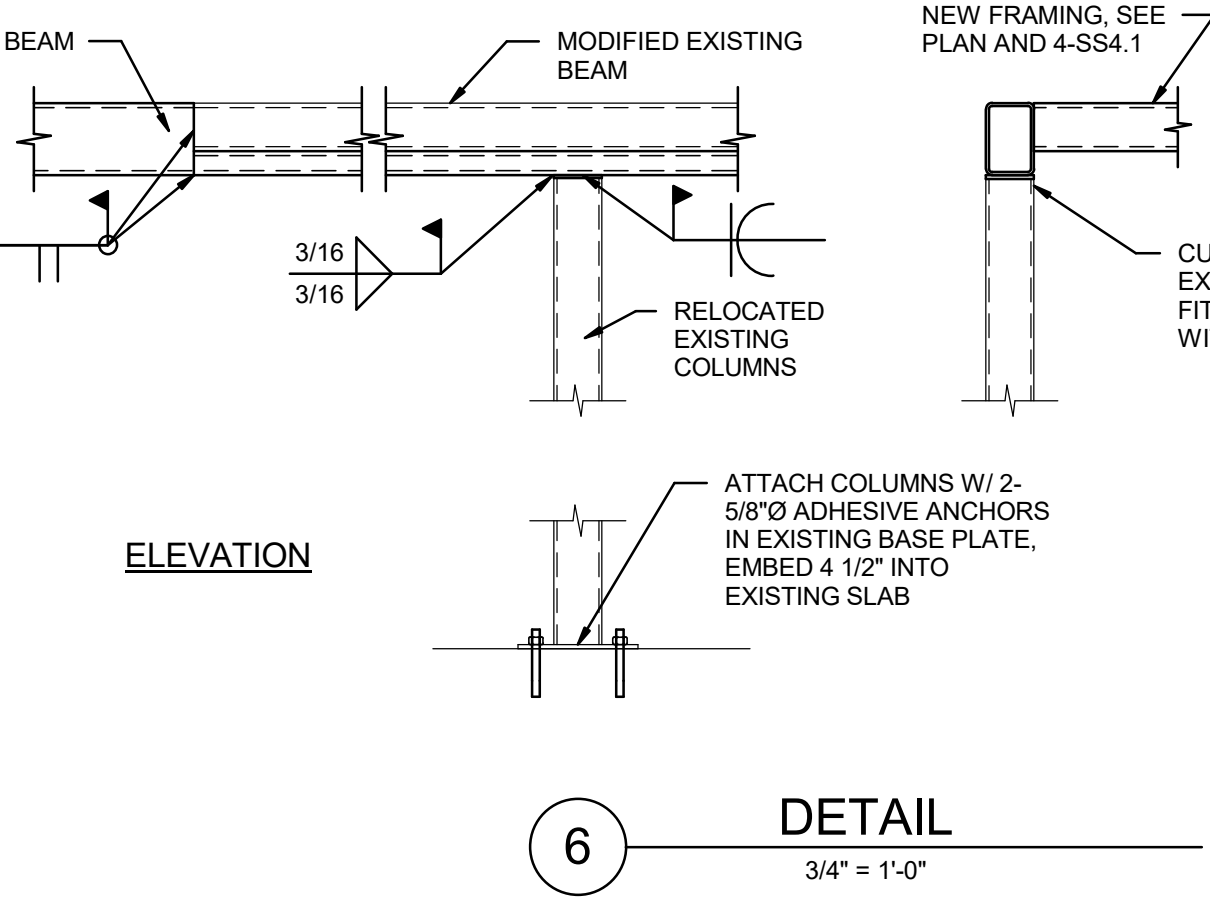
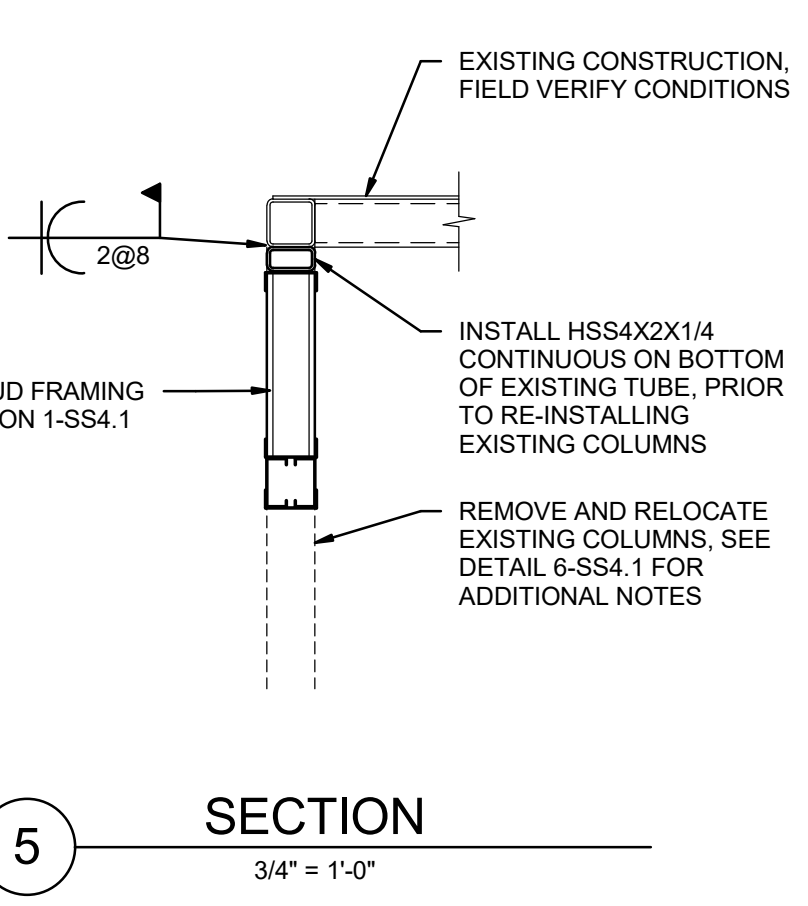
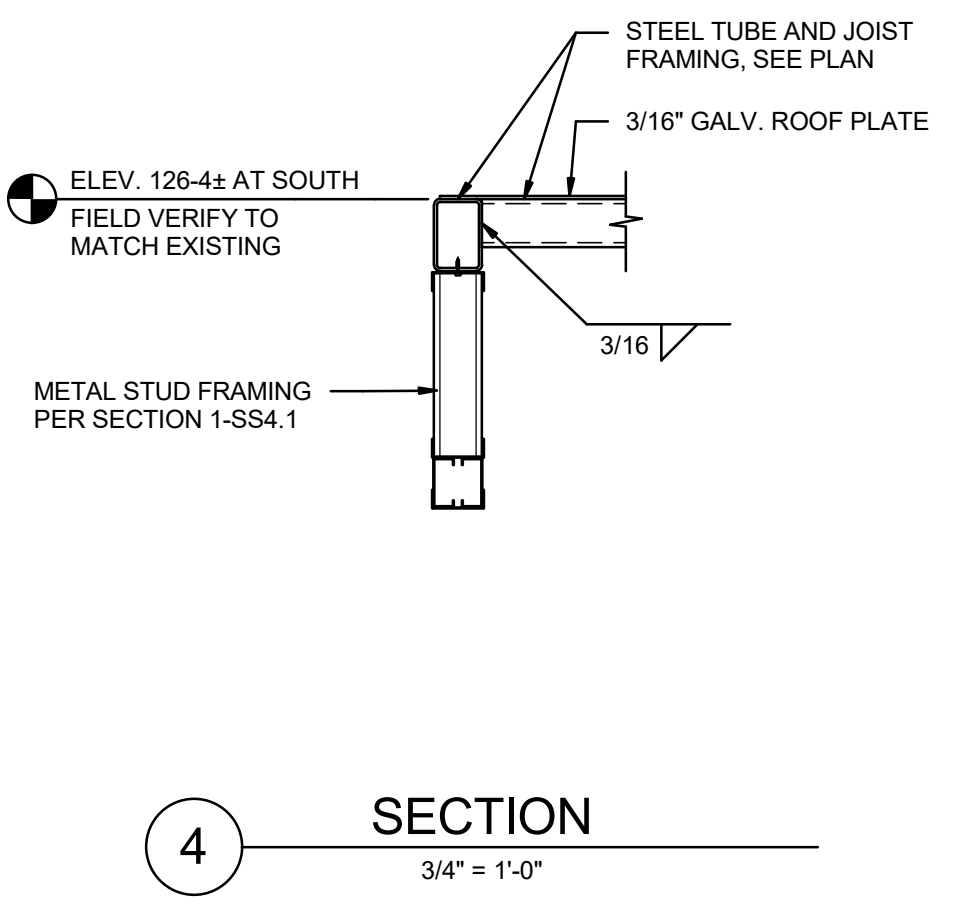
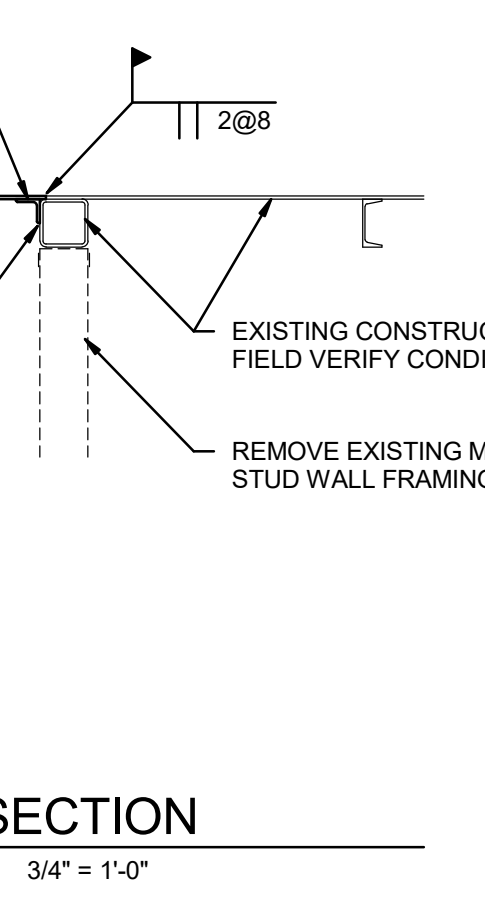
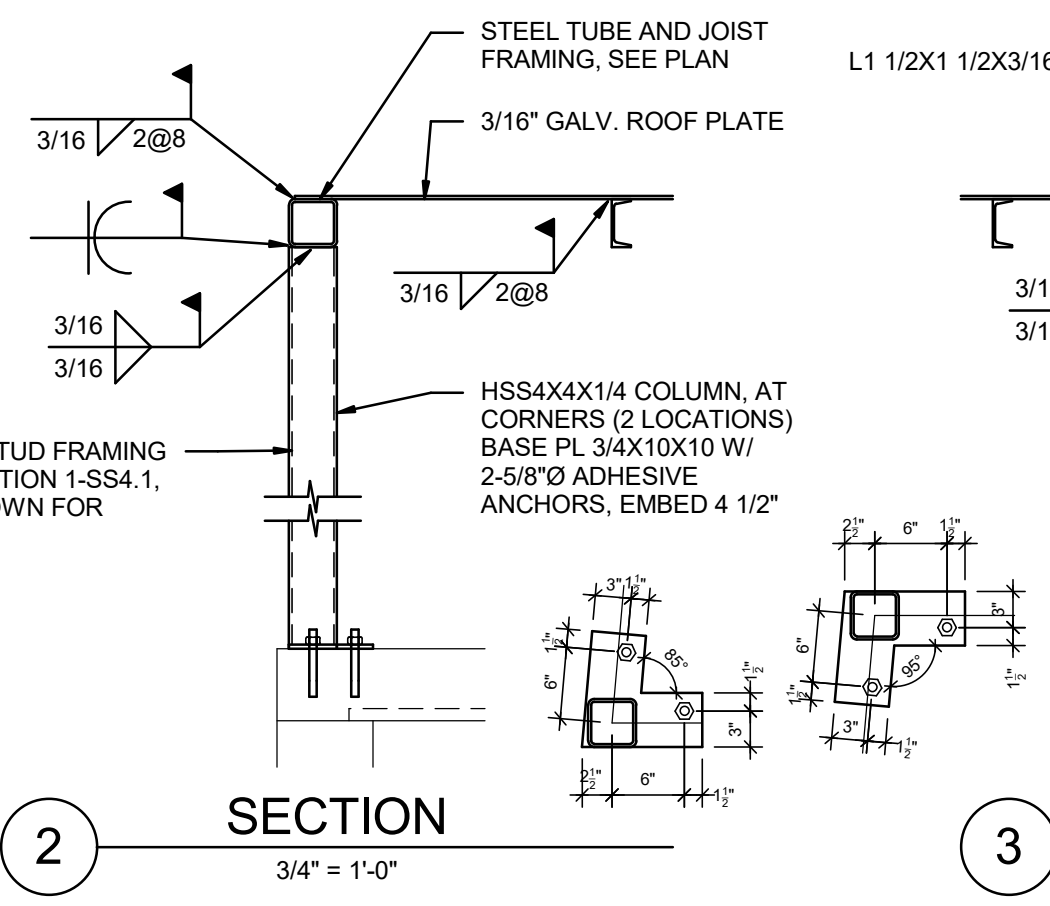
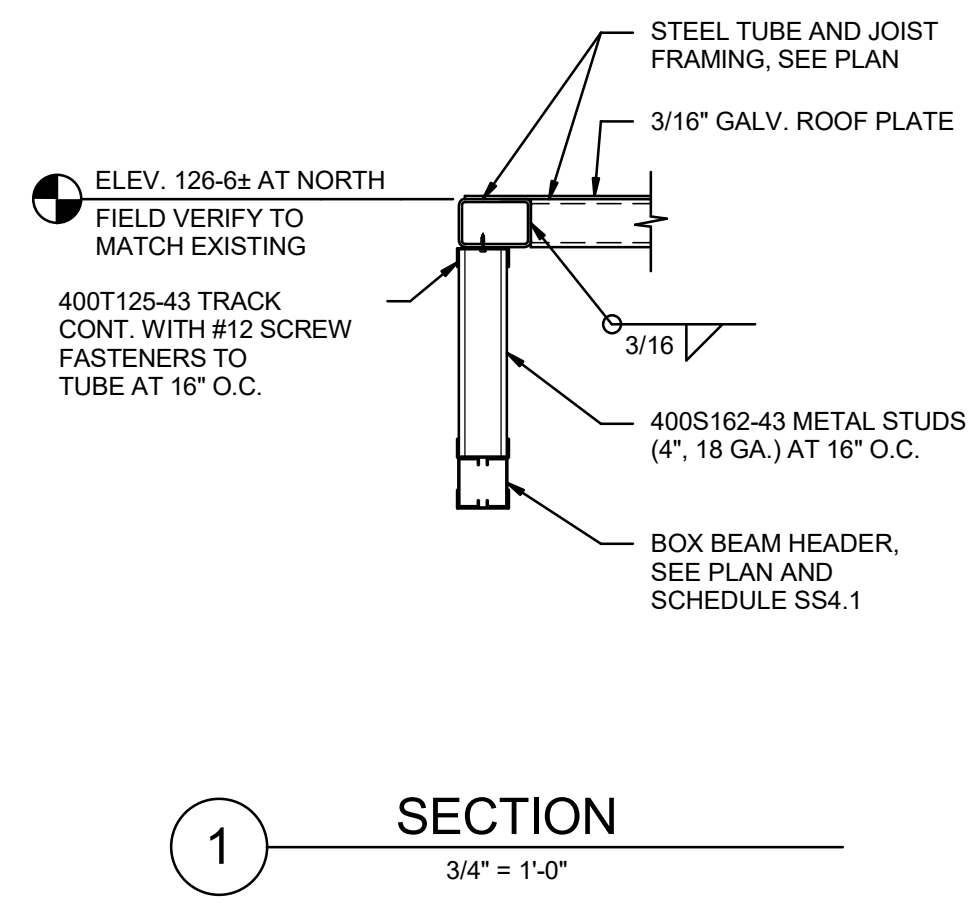

LINTEL SCHEDULE

MARK	MEMBERS	TYPE	REMARKS
L1	8\"/>		
L2	2-600S162-43 JOISTS	C	(A) (B)

LINTEL SCHEDULE NOTES:

- VERIFY SIZE, LOCATION, AND ELEVATION OF ALL WALL OPENINGS WITH THE ARCHITECTURAL DRAWINGS, THE MECHANICAL DRAWINGS AND THE MECHANICAL CONTRACTOR.
- USE SPECIAL U-SHAPED BOND BEAM LINTEL BLOCK UNITS AT ALL MASONRY BOND BEAM LINTELS.
- ALL MASONRY LINTELS ARE TO EXTEND 16\"/>

LINTEL REMARKS:

- (A) TRACK TOP AND BOTTOM, MATCH WIDTH AND GAGE OF WALL STUDS
- (B) PROVIDE BEARING FOR BOX BEAM ON 1 STUD AT EACH JAMB ADJACENT TO 2 STUDS FULL HEIGHT MATCHING DEPTH AND GAGE OF WALL STUDS. SEE JAMB DETAILS 15 AND 16-SS4.1.

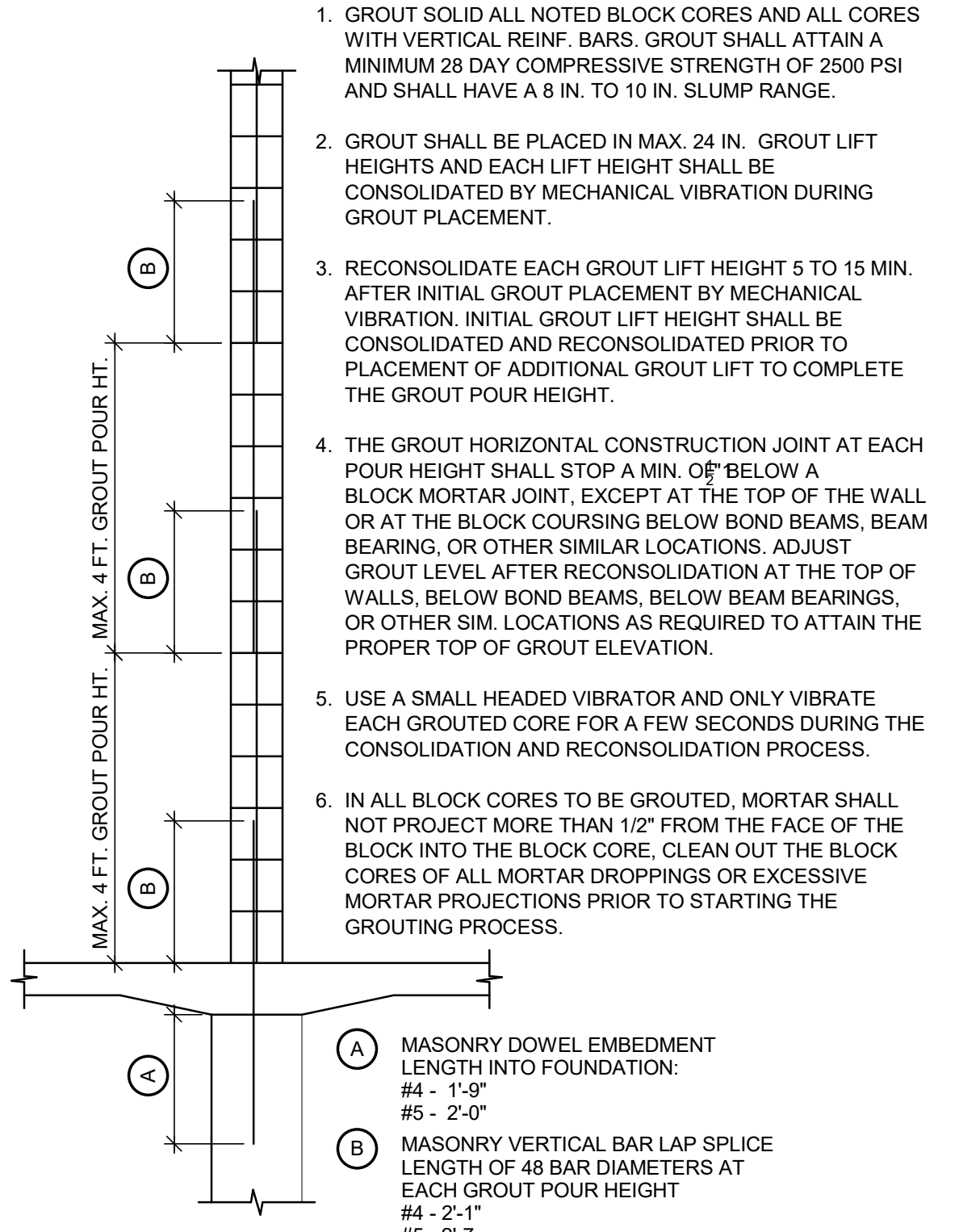

13 TYP. MAS. WALL REINF. DETAIL  
NO SCALE

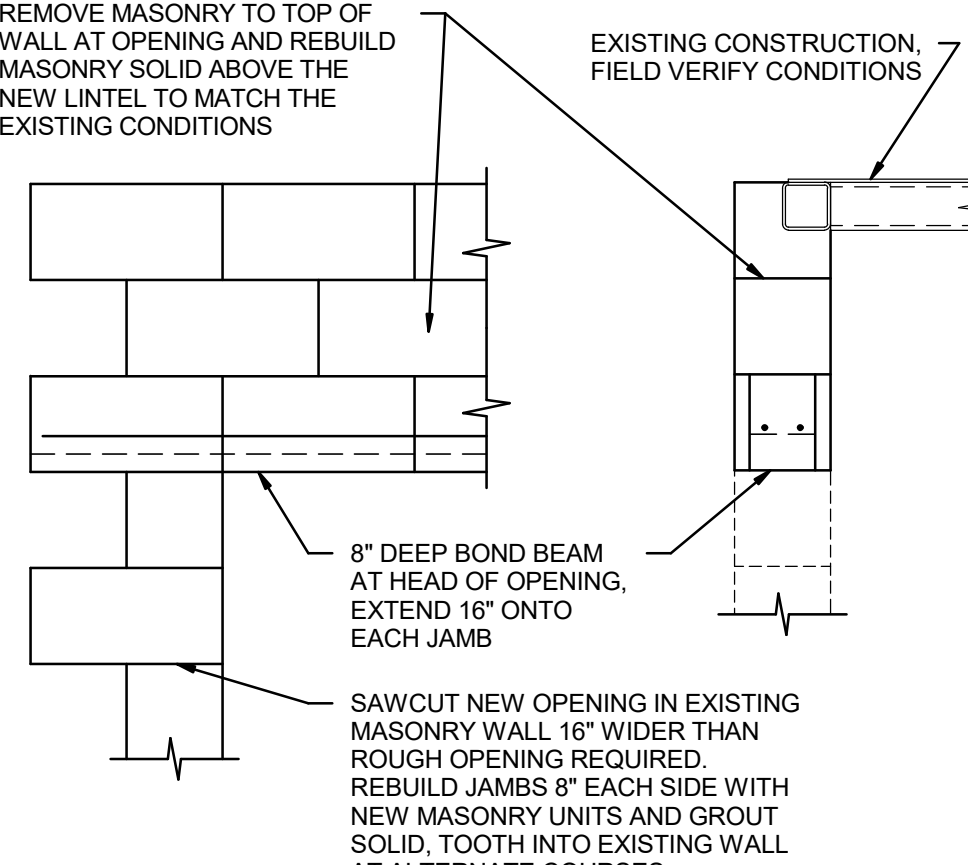

14 DETAIL  
3/4\"/>

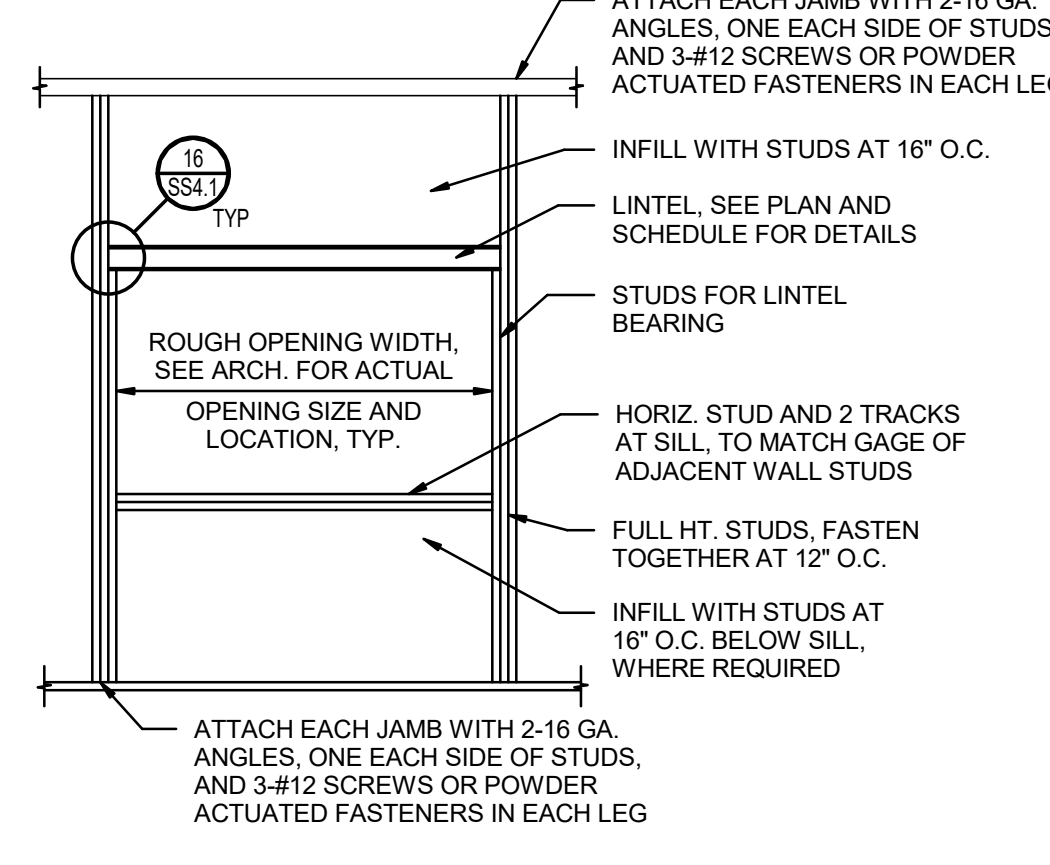

15 LINTEL DETAIL  
NO SCALE

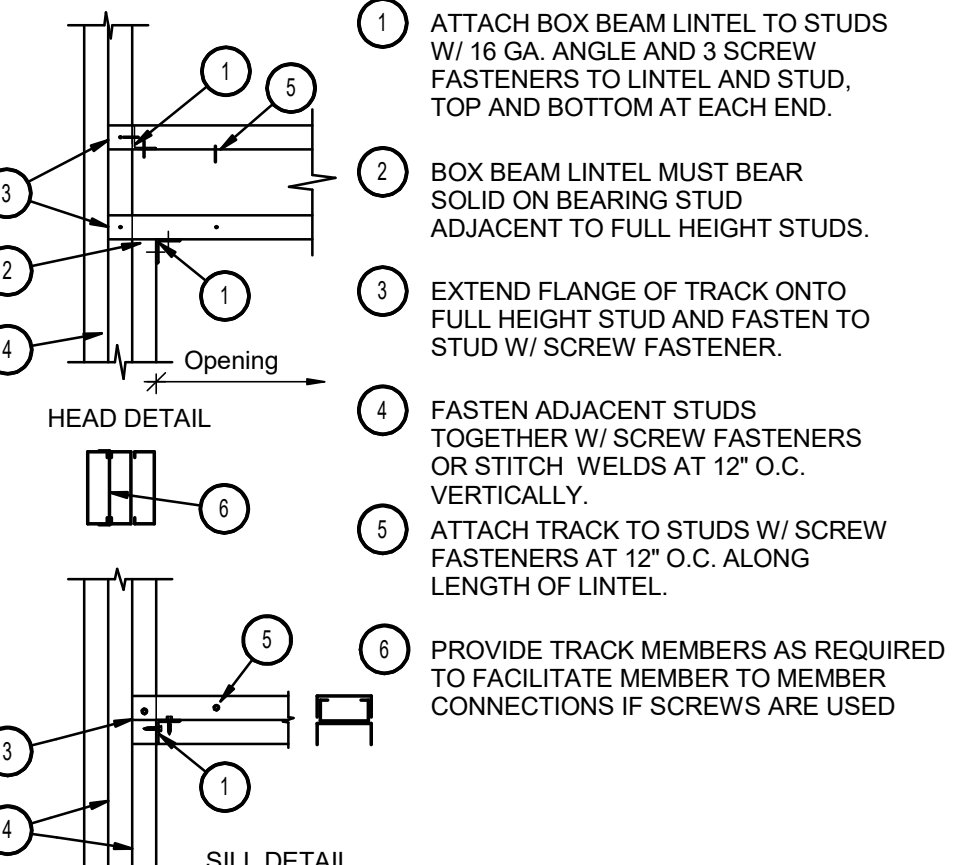

16 LINTEL DETAIL  
NO SCALE



©2023 MKEC Engineering All Rights Reserved  
These drawings and their contents, including but not limited to, all concepts, designs, & ideas are the exclusive property of MKEC Engineering (MKEC), and may not be used or reproduced in any way without the express consent of MKEC.

FRAMING SECTIONS

PROJECT NO.		
DATE	APR 2023	
SCALE	AS NOTED	
DESIGNED	DRAWN	CHECKED
DM	BN MB	DM

0	ISSUED FOR CONSTRUCTION	04-07-23
NO.	REVISION	DATE

SHEET NO. SS4.1

C:\Users\Manu\Documents\REVIT 2021\202408 Stryker Pressbox STRUCTURE 01\_ManualDrawn.rvt