

# GENERAL NOTES:

- The Contractor shall comply with all applicable safety regulations. All construction shall be completed following current City Standard Specifications and Special Provisions.
- Contractor will be required to provide notice to utility companies a minimum of seventy-two (72) hours prior to any excavation, as follows: Kansas One-Call 687-2470  
The Contractor must notify the following in case of an emergency:  
AT&T 1-800-246-8464  
Black Hills Energy 1-800-694-8989  
City of Wichita Water & Sewer 1-316-219-8921  
City of Wichita Stormwater 1-316-268-4090  
City of Wichita Traffic 1-316-268-4034  
Cox Communications 1-888-249-3530  
Kansas Gas Service 1-888-482-4950  
Westar Energy 1-800-544-4857
- Utility service lines, poles, etc. are to be adjusted as necessary by others prior to construction unless the plans specifically call for their adjustment by the Contractor or unless the plans specifically identify a utility to be adjusted by its owner during construction. Existing utilities and their location, as shown on the plans, represent the best information obtainable for design. The Contractor will be required to work around existing utilities within the right-of-way which do not conflict with proposed construction.
- Rubble from the removal of miscellaneous structures and excess excavation which is to be wasted shall be disposed of on sites to be provided by the Contractor. These sites shall be approved by the Engineer as to suitability, appearance and site location. Locations, in the opinion of the Engineer, that will leave an unsightly appearance will not be approved. All disposal sites must be approved by the Kansas Department of Health and Environment. Material either stockpiled or disposed of in a flood plain will require a Kansas State Board of Agriculture permit. Any material dumped in waters of the United States or wetlands is subject to U.S. Corps of Engineers permitting regulations. Any material buried or stockpiled beyond approved construction limits will require additional archaeological investigations unless buried in a previously approved borrow location.
- Trees and shrubs in public right-of-way which are in direct conflict with proposed new construction shall be removed by the Contractor with the City Engineer's approval. Trees and shrubs which are not in direct conflict with proposed new construction shall be saved and protected from damage.
- The Contractor shall give all property owners and/or tenants of developed property abutting the construction of this project a minimum of ten (10) days notice prior to start of construction.
- The Contractor shall be responsible for preserving property irons. The Contractor will be required to re-establish any property irons which are damaged or destroyed by his construction operations. Such irons shall be re-established by a licensed land surveyor in accordance with state laws.
- The Engineering Division shall field locate water valves one time during construction when requested by the Contractor. It shall be the Contractor's responsibility to preserve such field locations during the construction process. Water valves, valve boxes or fire hydrants damaged during construction shall be repaired by Contractor at his own expense. Valve boxes and water meters within the project limits shall be adjusted to match final grades by the contractor.
- The Contractor shall notify the inspecting engineer and Dawnita Reinhardt at 316-650-0740 with the City of Wichita with the anticipated construction start date and notify them of project completion. Staking and inspection for this project will be the responsibility of the Contractor.
- If traffic will be impacted by construction, a traffic control plan must be submitted and approved by the City Traffic Engineer, Mike Armour at [traffic@wichita.gov](mailto:traffic@wichita.gov) before construction can begin. The Contractor shall be responsible for all traffic control measures to facilitate construction. All construction zone markings and signage shall conform to the latest version of the Manual on Uniform Traffic Control Devices (MUTCD) as published by the US Dept. of Transportation, Federal Highway Administration. All costs associated with construction markings and signage shall be the Contractors responsibility.
- All elevations shown are NAVD 88.
- All areas disturbed during construction that will not be under proposed pavement shall be restored to match existing conditions.
- Maintain a minimum of 10' horizontal separation between all water lines (mains, services, and fire hydrants) and all sanitary sewer lines (mains, services, and manholes). All separation distances are to be measured from edge-to-edge, at the closest point.
- Maintain a minimum of 2' vertical separation between all water lines (mains and services) and all gravity sanitary sewer lines (mains, services, and manholes) at crossings. All separation distances are to be measured from edge-to-edge, at the closest point.
- Maintain a minimum 2' vertical separation between all water lines (mains and services) and all pressurized sanitary sewer lines (force mains and services) at crossings. Waterlines must always be placed above pressurized sanitary sewer lines where they cross. All separation distances are to be measured from edge-to-edge, at the closest point.
- Any sidewalk, drive approach, curb, or street pavement removed to construct project must have a pavement cut permit and be replaced by the City contractor. Permits can be obtained by calling 316-268-4501 or 316-268-4480.
- All applicable fees (tap, equity, in lieu of & main benefit) must be paid before any connections can be made on this project. Quotes can be obtained on fees by calling 316-268-4555.
- City maintenance of water mains ends at right-of-way or easement line or within two feet of vault.
- Opening and closing of water valves shall be done slowly to prevent damage to the water distribution system from water hammer. All valves closed by the contractor must be reopened as new construction permits. The project inspector must ascertain that any valve closed by the Contractor is reopened. The contractor will be permitted to operate water valves only when the project inspector assigned to the project is present.
- The Contractor shall lay a Tracer Wire and Set Test Stations along all water pipe installed in accordance with City Specifications and Tracer Wire Detail on detail sheet WL-101, cost is subsidiary to pipe installation.
- The contractor shall provide materials for temporary blowoff of waterlines. Connections to the existing waterline(s) shall be made with clean, swabbed pipe and flushed upon completion of tie-ins.
- Requests for short term water interruptions shall be made to the City Water Distribution Division and will be subject to their approval. The Contractor shall give written notice to any property owner, business, and/or tenants that will have water service interrupted at least 5 days in advance. Such notifications should indicate the time and date that the water will be turned off and when the service will be restored. No business, property owner, and/or tenants shall be without water service for more than 8 hours. Proposed tie in locations which will affect water service to property owners shall be performed during non-peak hours.
- The Contractor must schedule the connections to the existing main with the City such that there is a minimum disruption of service. Connections shall be made during periods of low water usage. The Contractor shall submit his proposed schedule for completing work for City approval at least 10 days prior to beginning construction.
- Deflections at pipe joint or couplings shall not exceed the pipe manufactures recommended maximum. Where deflections are greater than the maximum allowed, the contractor shall utilize fittings.
- Any existing joint exposed during excavation shall be replaced if within four feet of proposed joint.
- Valves 12 inch and larger are to be operated by the City Water Distribution Division, 48 hours of advance notice is required with the water Dispatch at 316-291-8921.
- All wet taps shall be installed by the City of Wichita. The Contractor will reimburse the City for tapping fees prior to tap being made. Unless noted on plans.
- The Contractor shall protect from damage and support existing utilities through construction as approved by the utility owner and the Engineer at the contractors expense.
- Contractor shall limit the extent of trench openings overnight and weekends to less than 50 feet.
- Wichita Fire Department inspections may be scheduled by calling Dawnita Reinhardt at 316-650-0740.
- The Contractor shall not begin work on the project until the Project Inspector is assigned and on site. Any work completed without inspection will be required to be uncovered for inspection at the Contractor's expense.

## BENCHMARKS

- Site Benchmark - 1  
"□" chiseled on top of curb, 64.0' north & 71.4' east of the northeast corner of the Lot 1 "across the street", Sauder Addition, Wichita, Sedgwick County, Kansas.  
Elevation = 1301.14 (NAVD 88)
- Site Benchmark - 2  
"X" chiseled on top of concrete, approx. 43.9' west & 1.2' south of southwest Corner of the Lot 1, Sauder Addition, Wichita, Sedgwick County, Kansas.  
Elevation = 1302.58 (NAVD 88)

**Begin: August 2022**  
**End: December 2022**

# WATER DISTRIBUTION SYSTEM

to serve

**Lot 1 3665 W. McCORMICK AVE.**

## Sauder Addition

CITY OF WICHITA, KANSAS

Gary Janzen, P.E. City Engineer  
Project Number: PPW-2022-010829  
54030980

## SHEET INDEX

Title Sheet	1
Lines 1 & 2	2
Std. Water Assembly Detail	3
Miscellaneous Water Details	4
Erosion Control Details	5-9
Copy of Plat	10
As-Built Sketch	11

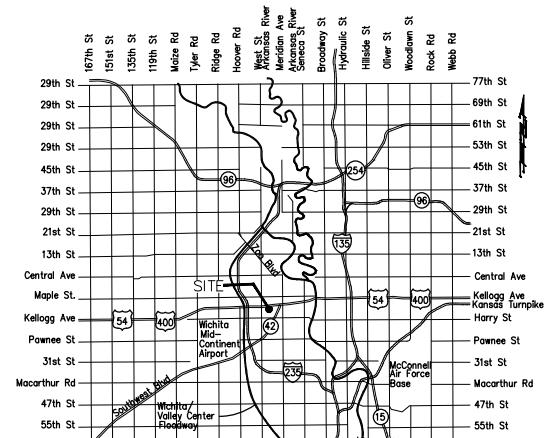

Vicinity Map

# AS-BUILT PLANS

Utility Contractor: Wilks Underground  
Inspector: Larry Powell - Baughman Company  
As-Built By: L. Powell 1-26-2023

- 1- Fire Hydrant = Mueller 250WP, 4-1/2"
- 1- 6" Valve = Mueller
- 1- 8" TAP Valve = CLOW
- 8" RJ PVC Pipe = NAPCO
- 6" PVC Pipe = Northern Pipe Products
- 6" DICL Pipe = American
- 8" DICL Pipe = American

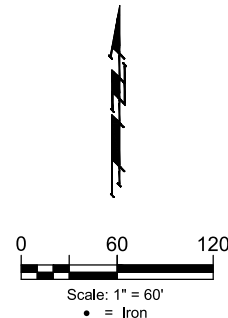
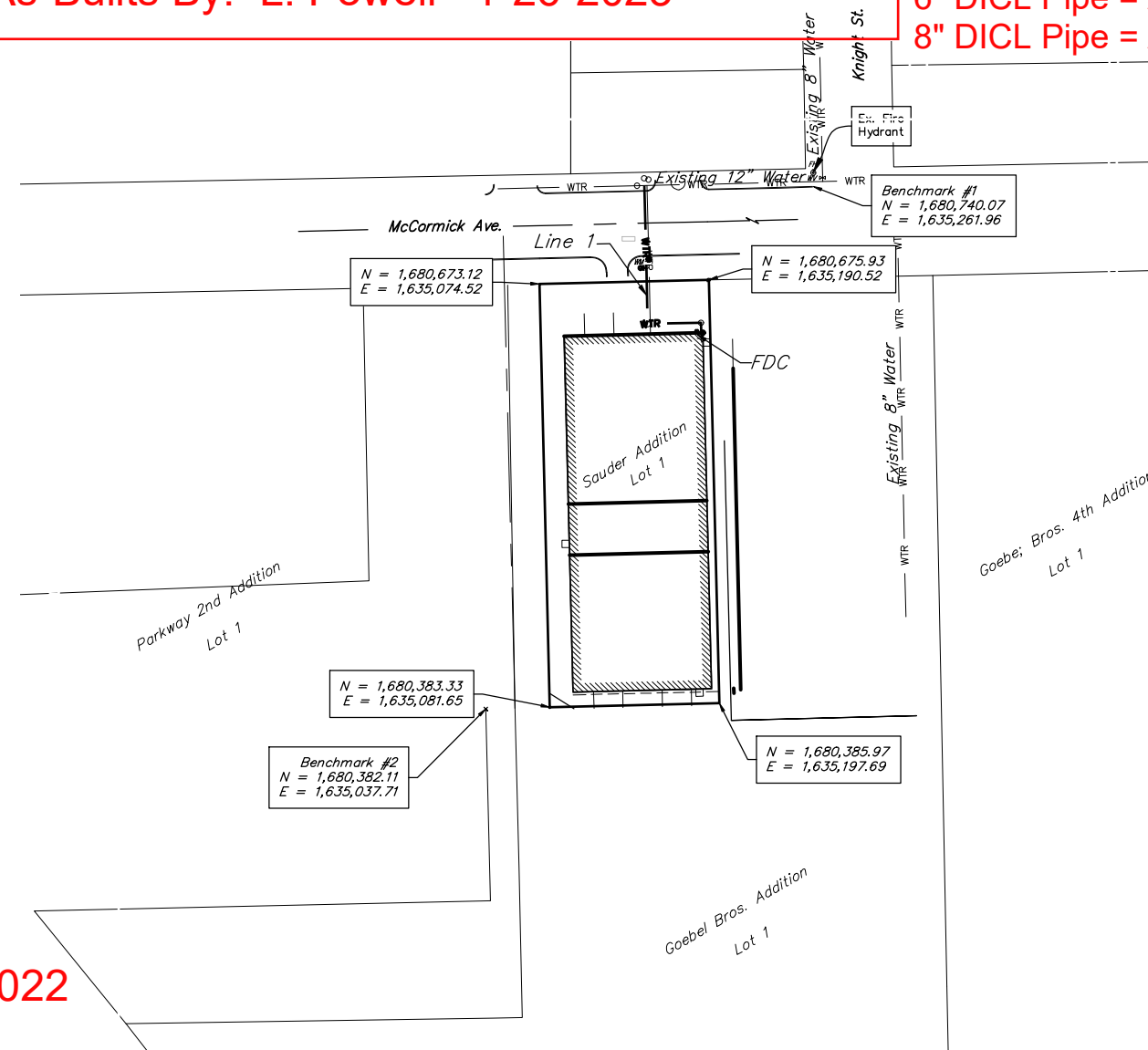

APPROVED AS NOTED  
BY WICHITA PUBLIC WORKS  
ENGINEERING DIVISION  
& BY WICHITA FIRE DEPARTMENT

Engineering approved by Shawn Mellies on 06.08.22  
Utilities approved by Greg Lolley on 06.08.22  
Fire Dept. approved by Jose Oadiz on 06.08.22

NOTE TO CONTRACTORS

Public Property:  
Inspection and testing for the waterline is to be provided by a Licensed Consulting Engineering Firm under contract with the Owner/Developer. Said Inspection is to be in accordance with the City of Wichita standard construction engineering practices and certified by a Professional Engineer Licensed in the state of Kansas. No work shall be performed in dedicated easements or public right-of-way by the Contractor without such inspection nor shall any work be commenced without written authorization by City Engineering. All Construction and Materials shall comply with the City of Wichita Specifications and Standards and Special Provisions (on file and available in the City Engineer's Office) or on the City's Website.

Private Property:  
Installation and testing for the fire protection line is to be performed by a City of Wichita licensed fire protection contractor in accordance with the fire codes as adopted by the City of Wichita. All material and construction practices for the fire protection line shall comply with the fire codes as adopted by the City of Wichita (available from the City of Wichita Fire Department). The Contractor shall not commence work without notification and approval of the Wichita Fire Department. Inspection of the fire protection line is to be provided by a licensed Engineering Firm under contract with the Owner/Developer and the Fire Department. The contractor shall not start work until the project inspector is assigned to the project and present on the site. Any work done without inspection will be required to be uncovered for inspection.

An approved copy of these plans signed by City staff are required on-site.

**BAUGHMAN JOB # 22-08-E263**

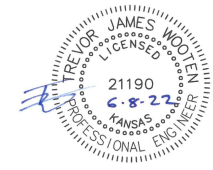

Mar. 2, 2022

**BAUGHMAN COMPANY**  
315 Ellis St. Wichita, KS 67211 316-262-7271  
BaughmanCo.com

# BENCHMARKS

Site Benchmark - 1  
 "□" chiseled on top of curb, 64.0' north & 71.4' east of the northeast corner of the Lot 1 "across the street", Sauder Addition, Wichita, Sedgwick County, Kansas.  
 Elevation = 1301.14 (NAVD 88)

Site Benchmark - 2  
 "X" chiseled on top of concrete, approx. 43.9' west & 1.2' south of southwest corner of the Lot 1, Sauder Addition, Wichita, Sedgwick County, Kansas.  
 Elevation = 1302.58 (NAVD 88)

City maintenance of water mains ends at right-of-way line.

TAP Saddle = 27' N of CL of McCormick Ave.  
 148' W of CL of Knight St.  
 TAP Valve = 28.5' N of CL of McCormick Ave.  
 148' W of CL of Knight St.

90 Degree Rolled Bend =  
 31' N of CL of McCormick Ave.  
 148' W of CL of Knight St.

90 Degree Rolled Bend =  
 31' N of CL of McCormick Ave.  
 151' W of CL of Knight St.

Contact utility companies 3 weeks prior to construction to coordinate construction.  
 Heide Bryan, Evergy, (316) 261-6354  
 Shannon Brinkmeyer, AT&T (316) 268-2931

NOTE:  
 SEE SHEET #11 FOR  
 ATTACHED "AS-BUILT  
 SKETCH"

## LEGEND:

(TS) = TEST STATION

DEPTH UNKNOWN  
 Contractor to Verify Depth & Location of Existing Water and Sewer Lines Prior to Construction. Field adjust as necessary.

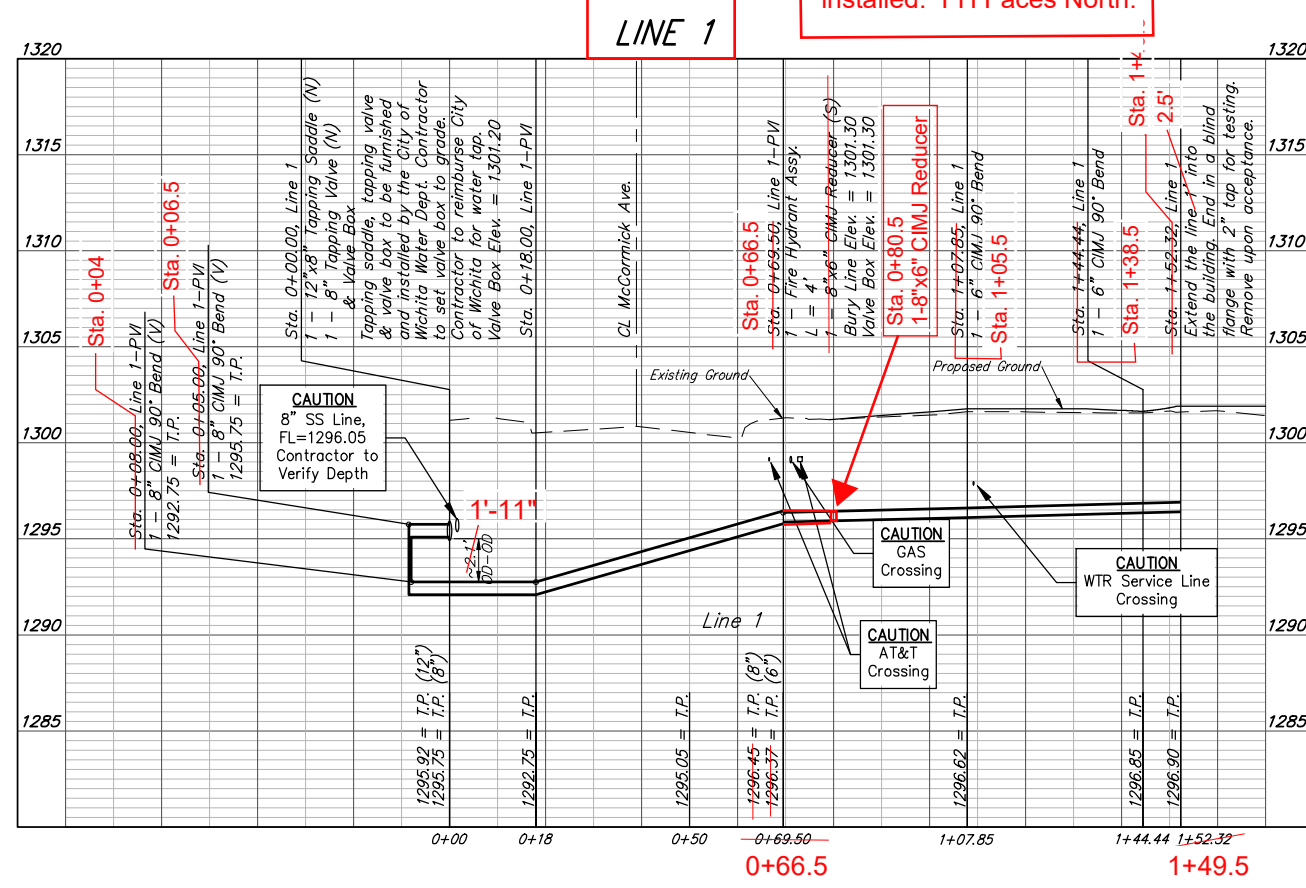
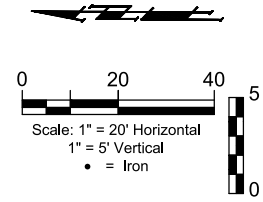
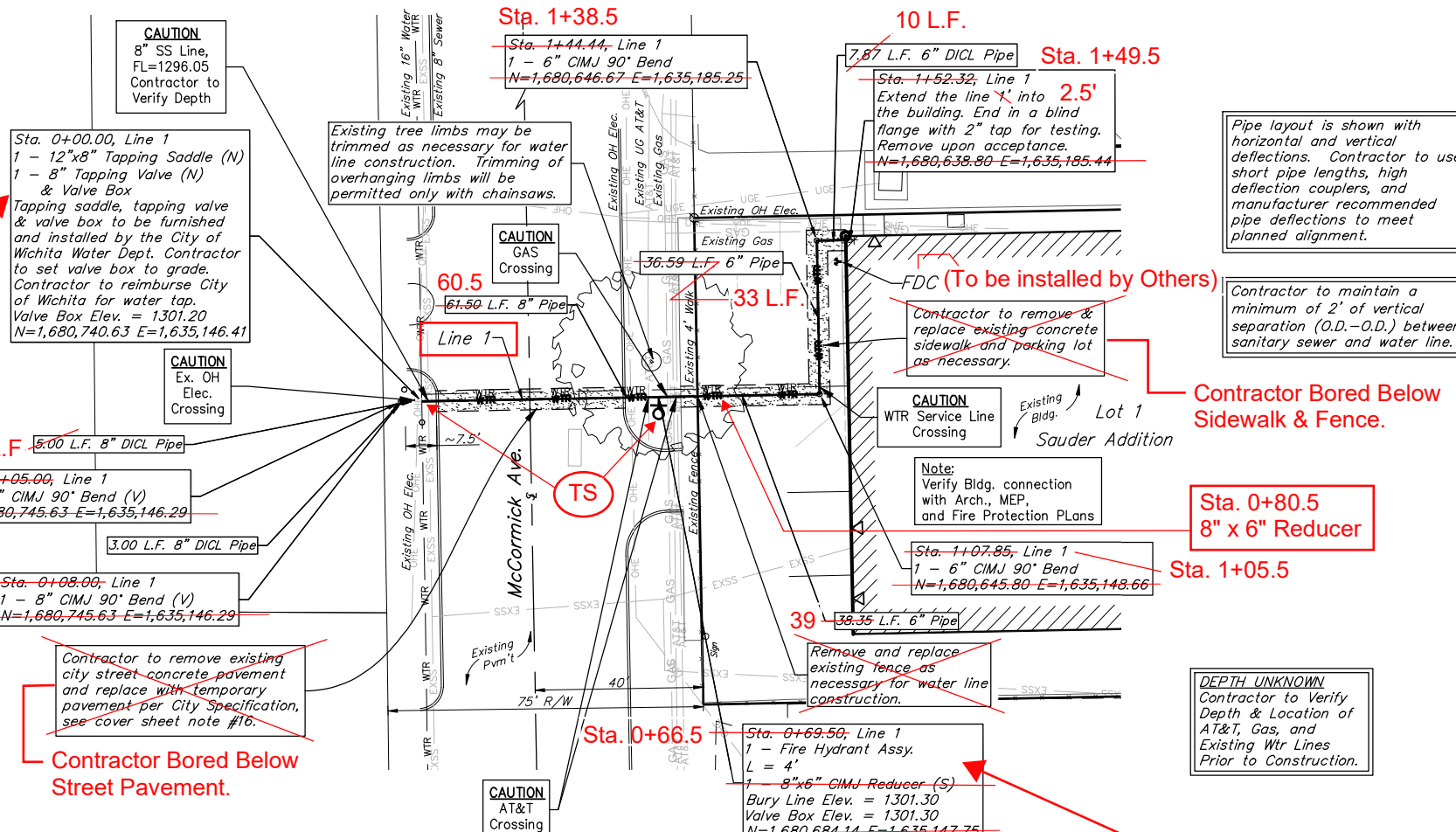

8"x6" FH TEE =  
 29.5' S of CL of McCormick Ave.  
 143' W of CL of Knight St.  
 6" Fire Hydrant Valve =  
 29.5' S of CL of McCormick Ave.  
 144' W of CL of Knight St.  
 Fire Hydrant =  
 29.5' S of CL of McCormick Ave.  
 147' W of CL of Knight St.

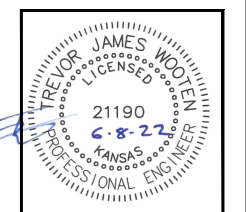

**BAUGHMAN COMPANY**  
 315 Ellis St.  
 Wichita, KS 67211  
 316-262-7271  
 BaughmanCo.com

Star Lumber  
**PPW Line 1**  
 Water Line Improvements  
 PROJECT NUMBER:  
 21-09-E011  
 DESIGN: ENG DRAWN: JA  
 DATE: Mar. 2, 2022  
 SHEET 2 OF 10

File: E:\Projects\Star Lumber McCormick Building\Engineering\Phase 1\PPWSLB.PPW.dwg

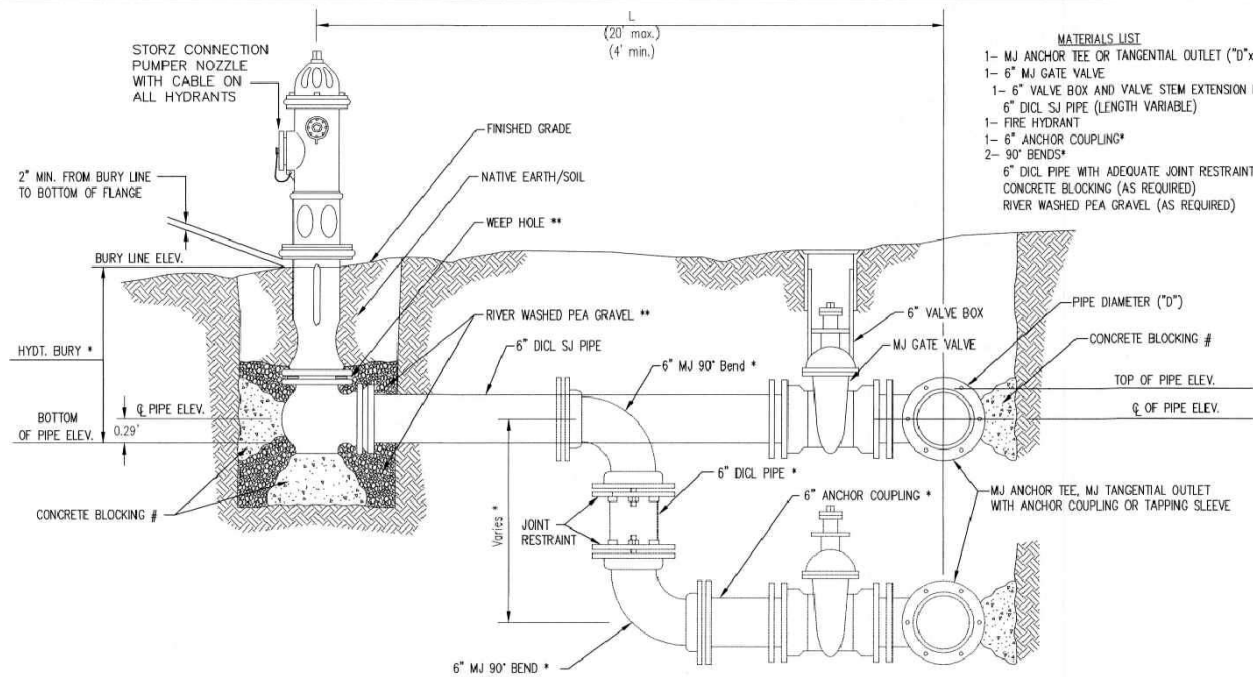

- MATERIALS LIST**
- 1- MJ ANCHOR TEE OR TANGENTIAL OUTLET (10" x 6")
  - 1- 6" MJ GATE VALVE
  - 1- 6" VALVE BOX AND VALVE STEM EXTENSION IF REQUIRED \*
  - 6" DI CL SJ PIPE (LENGTH VARIABLE)
  - 1- FIRE HYDRANT
  - 1- 6" ANCHOR COUPLING\*
  - 2- 90° BENDS\*
  - 6" DI CL PIPE WITH ADEQUATE JOINT RESTRAINT \*
  - CONCRETE BLOCKING (AS REQUIRED)
  - RIVER WASHED PEA GRAVEL (AS REQUIRED)

\* IF THE REQUIRED HYDRANT BURY IS IN EXCESS OF 5', BUT LESS THAN 7', CONTRACTOR SHALL USE STANDARD 5' HYDRANT BURY AND HYDRANT BARREL EXTENSIONS AS NECESSARY. IF THE REQUIRED HYDRANT BURY IS GREATER THAN 7', CONTRACTOR SHALL USE 5' HYDRANT BURY, 2-MJ 90° BENDS, 6" ANCHOR COUPLING AND 6" DI CL PIPE AS NECESSARY FOR VERTICAL ADJUSTMENT. THE CONTRACTOR SHALL PROVIDE ADEQUATE THRUST BLOCKING AT HYDRANT AND MEAGALUGS, OR SIMILAR RESTRAINT BETWEEN 90° BENDS TO SECURE ALL FITTINGS DURING TESTING AND OPERATION. THE CONTRACTOR SHALL PROVIDE A VALVE STEM EXTENSION PER DETAIL THIS SHEET.

\*\* CAUTION: WEEP HOLES TO BE KEPT CLEAR DURING CONSTRUCTION AND BACKFILL. CONCRETE FOR THRUST BLOCKING SHALL NOT OBSTRUCT WEEP HOLES. PLACE 1 CUBIC FOOT OF RIVER WASHED PEA GRAVEL AROUND EACH WEEP HOLE.

# CONCRETE THRUST BLOCKING SHALL BE KEPT CLEAR OF BOLTS, NUTS, AND MJ ACCESSORIES.

**FIRE HYDRANT ASSEMBLY**  
PER CITY OF WICHITA SPECIFICATIONS

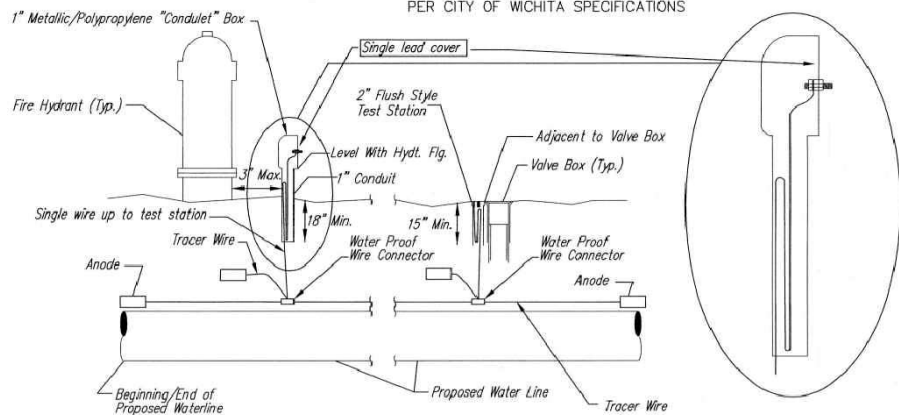

**TRACER WIRE**  
Conductive type pipe locator/tracer wire shall be install to locate all waterline pipe regardless of pipe material. The wire shall extend the entire length of the proposed pipe. The wire shall be taped to the waterline and pulled with the pipe. A waterproof connector shall be used at splice locations. A complete list of approved tracer wire and waterproof connectors can be found on the City of Wichita's website at [www.wichita.gov](http://www.wichita.gov).

**WIRE**  
The tracer wire shall be Blue No. 12 AWG CCS with 45 mil HDPE insulation. To allow for grade adjustment, a minimum of 12" of excess wire shall be coiled at the bottom of the test station for all wires. Wire connectors shall be installed per manufacturer recommendations. Contractor shall attach wire being installed with proposed water main to any tracer wire installed with adjacent waterline projects.

**TEST STATIONS**  
The test station for fire hydrant application shall be a 1" "condulet" style station as manufactured by AGRA Industries with a removable solid cover having a single lead extending from the face or approved equal. The "conduit" style test station shall be attached to a 1" rigid galvanized conduit with a minimum length of 36" and plastic end bushing. The flush style shall have the word "WATER" stamped or molded into the lid. The test station for valve applications shall be a 2" flush style test station with wire connector on lid. Model # T2PH7B1LP Handley Industries or CD14\*TP SnakePit as manufactured by Copperhead Industries or approved equal. The flush style shall have the word "WATER" stamped or molded into the lid. All test stations shall be manufactured using molded blue tops or sufficiently coated with blue enamel paint. The tracer wire and the anode wire shall be install to allow 12" of wire within the test station. The location of all test stations shall be recorded, and shown in the as-built drawings. Flush style test stations shall not be installed in pavement or sidewalk unless approved by the Engineer. Contractor shall extend tracer wire & move flush mount test station to nearest location out of pavement or sidewalk.

**ANODES**  
The anodes shall be 3 lb. bare zinc or magnesium. The anodes shall be buried at the same elevation as the waterline at each test station. The anodes shall be connected to 12 AWG CCS which shall be extended to the test station.

**TRACER WIRE DETAIL**  
COST IS SUBSIDIARY TO PIPE INSTALLATION

FIRE HYDRANTS REQUIRED				
STATION	BURY LINE ELEVATION	TOP OF PIPE ELEVATION	FIRE HYDRANT BURY REQUIRED*	VALVE STEM EXT. REQUIRED (ft)*
0+69.50	1301.30	1296.45	-5.5'-6.5'	1.0'
0+66.5				

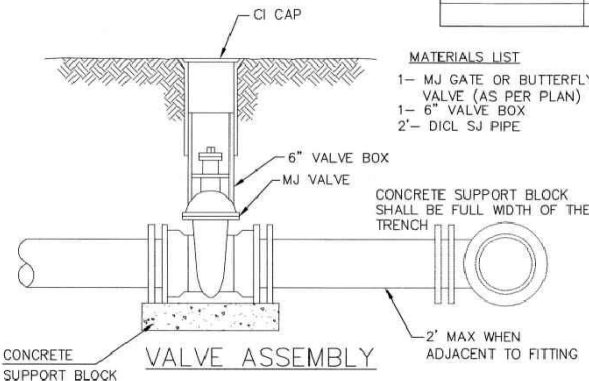

- MATERIALS LIST**
- 1- MJ GATE OR BUTTERFLY VALVE (AS PER PLAN)
  - 1- MJ ANCHOR COUPLING (12" OR SMALLER)
  - 1- 6" VALVE BOX
  - CONCRETE SUPPORT BLOCK SHALL BE FULL WIDTH OF THE TRENCH

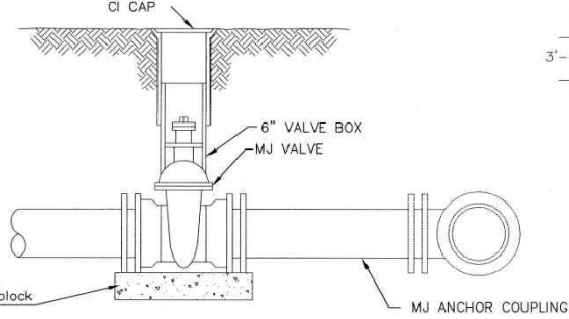

**ANCHORED VALVE ASSEMBLY**

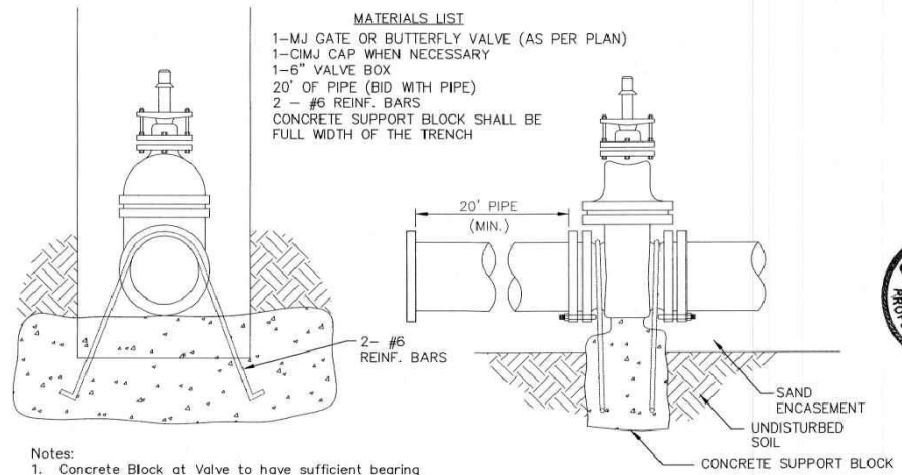

- Notes:**
1. Concrete Block at Valve to have sufficient bearing in undisturbed soil to prevent thrust movement as shown in table at right. Field Engineer to determine thrust loading of undisturbed soil and final size of thrust block.
  2. The thrust block shall be constructed such that bolts, nuts, and other MJ accessories are kept clear of concrete.
  3. All valves at dead ends and at other locations as called out on the plans shall be blocked as shown here.

THRUST AT VALVES	
VALVE	THRUST AT 150 #/sq ft
4"	1809 lbs.
6"	4245 lbs.
8"	7540 lbs.
12"	16965 lbs.

**ANCHORED VALVE ASSEMBLY, SPECIAL**

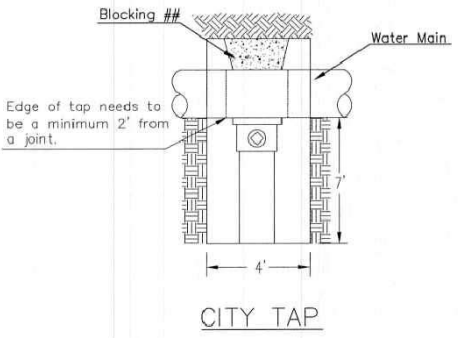

- MATERIALS LIST**
- 1- MJ GATE OR BUTTERFLY VALVE (AS PER PLAN)
  - 1- 6" VALVE BOX
  - 2"- DI CL SJ PIPE

## When the City of Wichita makes tap, blocking is to be done by Contractor

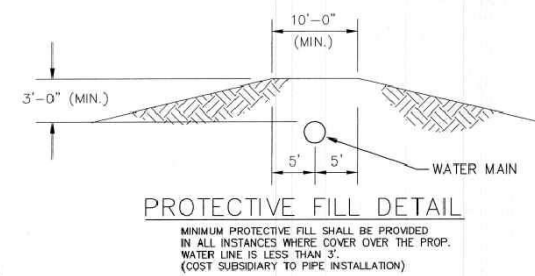

MINIMUM PROTECTIVE FILL SHALL BE PROVIDED IN ALL INSTANCES WHERE COVER OVER THE PROP. WATER LINE IS LESS THAN 3'. (COST SUBSIDIARY TO PIPE INSTALLATION)

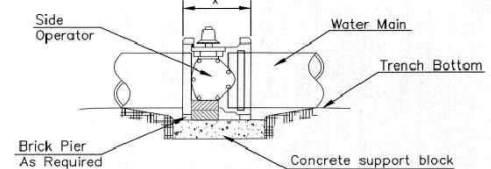

- NOTES**
1. This detail covers Butterfly Valve installation, inclusive, regardless of type of pipe or joint used. 24" and larger lines to be detailed on plans.
  2. 6" Valve Box and Cover required per City of Wichita Std. Specifications.
  3. Conc. Support Block to be full width of trench.

**CONCRETE SUPPORT BLOCKING FOR BUTTERFLY VALVE INSTALLATION**

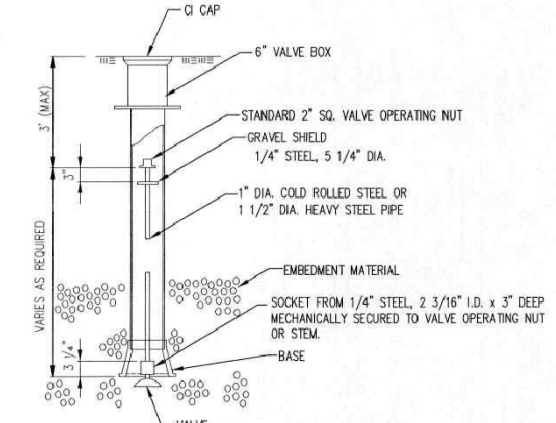

**VALVE STEM EXTENSION DETAIL**

NOTE: ONE VALVE STEM EXTENSION FOR EACH VALVE BURIED GREATER THAN 5'.

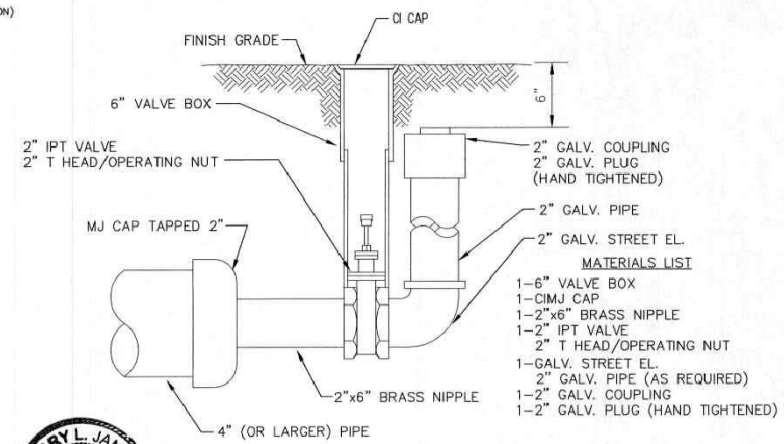

**2" BLOWOFF ASSEMBLY**



**CITY OF WICHITA**  
PUBLIC WORKS & UTILITIES  
ENGINEERING DIVISION

**STANDARD WATER ASSEMBLY DETAIL**  
CITY ENGINEER  
**GARY JANZEN, P.E.**

PROJECT NUMBER	OCA NUMBER	DATE
----------------	------------	------

CITY ENGINEER'S OFFICE  
CITY HALL - SEVENTH FLOOR  
455 NORTH MAIN STREET  
WICHITA, KANSAS 67202-1620  
(316) 268-4501

SHEET  
**3 of 10**

REVISED: OCTOBER 2016

# SAUDER ADDITION

TO WICHITA, KANSAS.

D 7-10

State of Kansas } s.s. We, Baughman Company, Surveyors in Sedgewick county and state do hereby certify that we have surveyed and plotted "SAUDER ADDITION" to Wichita, Kansas, and that the accompanying plat is a true and correct exhibit of the property surveyed, described as beginning at a point 1360 feet west of the N.E. corner of the SW 1/4 of Sec. 25, Twp. 27-S, R-14-W; thence south parallel with the east line of said SW 1/4 330 feet; thence east parallel with the north line of said SW 1/4 140 feet; thence north 330 feet; thence west 140 feet to beginning.

Baughman Company Surveyors  
by William F. Pagan Engineer

I know all men by these presents that we, Norman E. Sauder and Faye W. Sauder, his wife, have caused the land described in the surveys certificate to be plotted into a lot and streets to be known as "SAUDER ADDITION" to Wichita, Kansas. The streets are hereby dedicated to and for the use of the public. An easement is hereby granted as indicated for the construction and maintenance of all public utilities.

Norman E. Sauder Faye W. Sauder

State of Kansas } s.s. Be it remembered that on this day of April 1965 before me a notary public in and for said county and state came Norman E. Sauder and Faye W. Sauder his wife, to me known to be the same persons who executed the foregoing instrument of writing and duly acknowledged the execution of the same. In testimony whereof I have hereunto set my hand and affixed my notarial seal the day and year above written.

George H. Hester Notary Public  
My Commission Expires 17 JULY 1966

This 6<sup>th</sup> day of May 1965 Entered on transfer record  
W. P. Williams County Clerk

State of Kansas } s.s. This is to certify that this plat Sedgewick County } s.s. was Filed for record in the office of the Register of Deeds this 6<sup>th</sup> day of May 1965, at 3:30 o'clock P. M. and is duly recorded.

Rufus E. Neering Register of Deeds  
Paul D. Dilbert Deputy

D 7-10

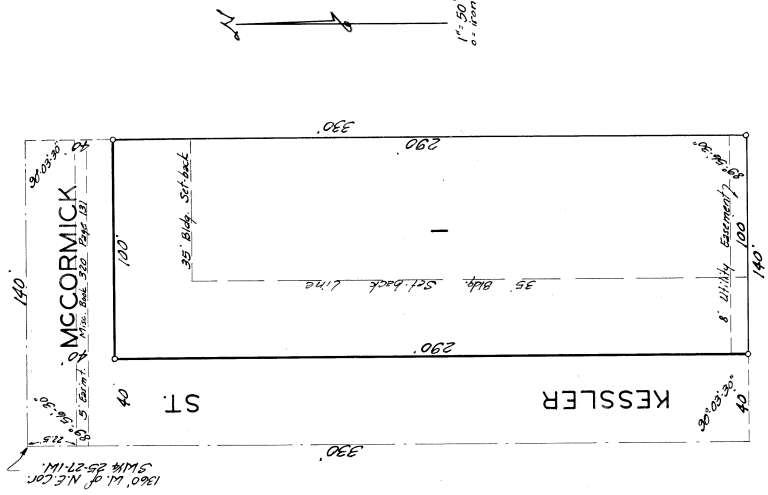

This plat of "SAUDER ADDITION" to Wichita, Kansas, has been approved by the Wichita-Sedgewick County Metropolitan Area Planning Commission, Wichita, Kansas, and is hereby transmitted to the Board of Commissioners of the City of Wichita, Kansas, with the recommendation that such plat be approved as proposed.

Dated this 1st day of April 1965.  
Wichita-Sedgewick County Metropolitan Area Planning Commission.

J. W. Dreyfus Chairman  
E. Bickley Jordan Secretary

Approved by the Board of City Commissioners this 1<sup>st</sup> day of May 1965.

Calvin Kavan Mayor  
Samuel Quich City Clerk

Approved by the Board of County Commissioners this 1<sup>st</sup> day of May 1965.

Alfred Schuchman Chairman  
Charles Peters Commissioner  
Tom Scott Commissioner  
W. P. Williams County Clerk

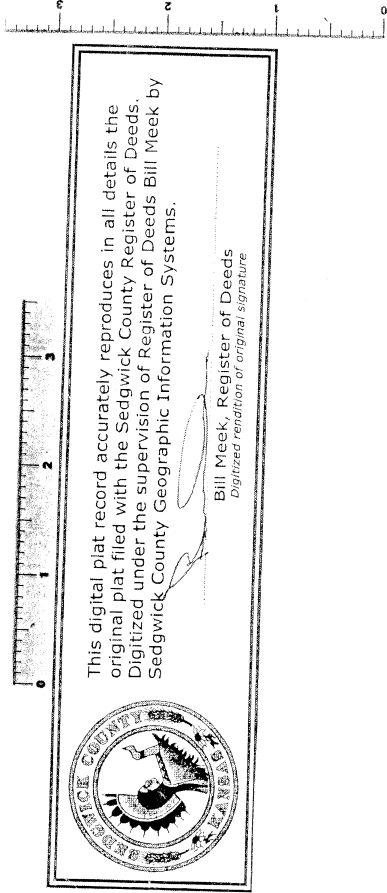

FOR REFERENCE ONLY  
NOT TO SCALE



**BAUGHMAN COMPANY**  
315 Ellis St.  
Wichita, KS 67211  
316-262-7271  
BaughmanCo.com

Star Lumber  
**Copy of Plat**  
Water Line Improvements  
PROJECT NUMBER:  
21-09-E011  
DESIGN: ENG DRAWN: JA  
DATE: Mar. 2, 2022  
SHEET **10** OF **10**

# AS-BUILT SKETCH of FIRE SERVICE LINE TO SERVE 3665 W. McCORMICK

**SAUDER ADDITION - LOT 1**  
 (STAR LUMBER WAREHOUSE)  
 COW # 2022-010829 PPW  
 Utility Contractor: WILKS UNDERGROUND  
 Inspection: BAUGHMAN CO. # 22-08-E263

← N  
 Not To Scale  
 L. Powell  
 Baughman Co.  
 8-19-22/1-26-23

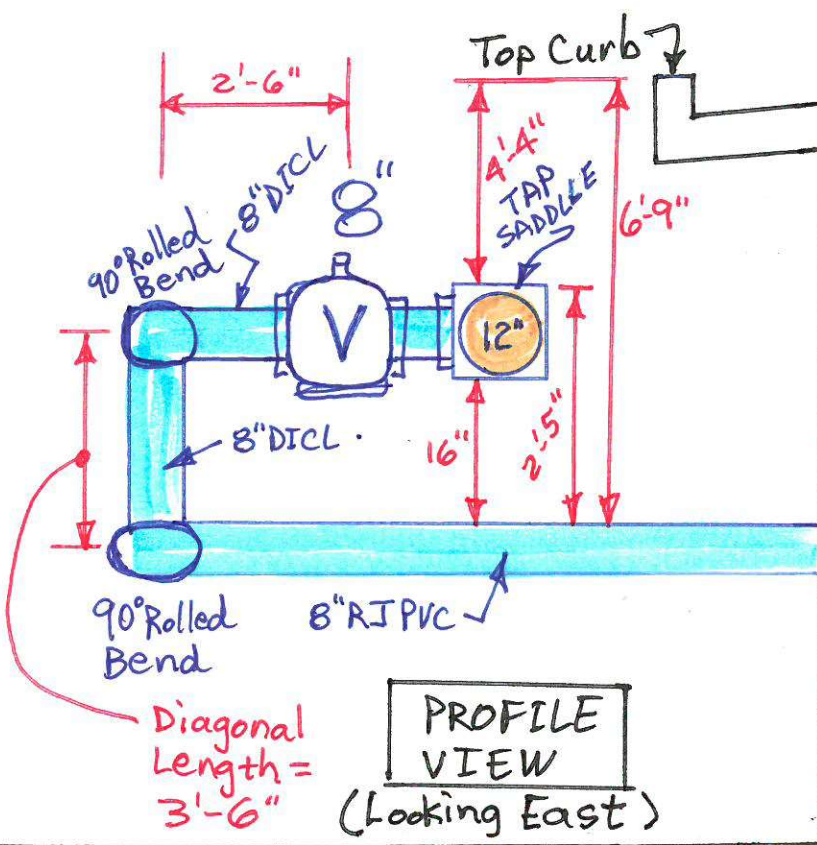

## LEGEND

- Ⓧ = Valve
- Ⓣ = Test Station
- Ⓜ = Fire Hydrant
- = Meg A Lugs
- Ⓢ = Sanitary Sewer Manhole

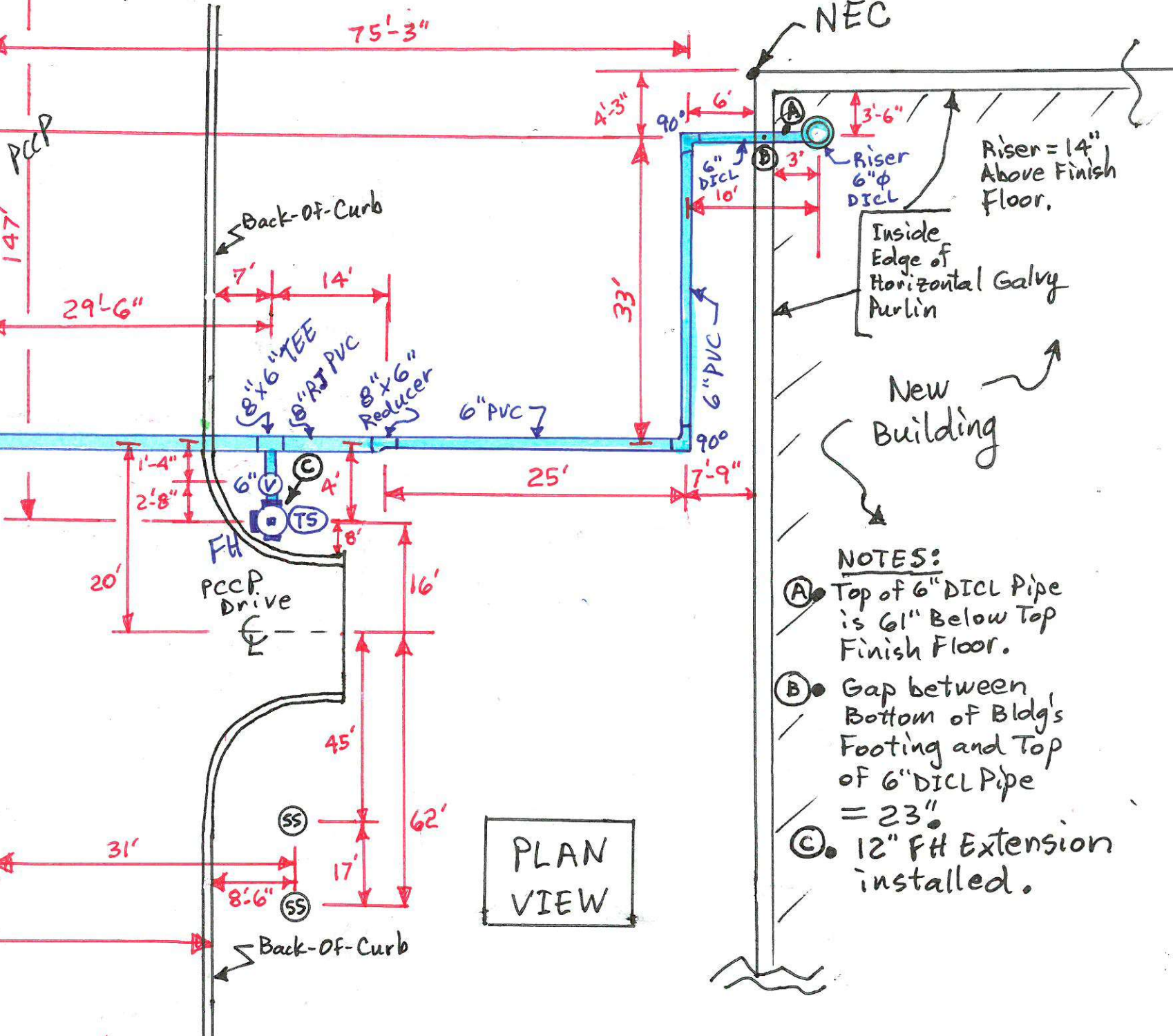
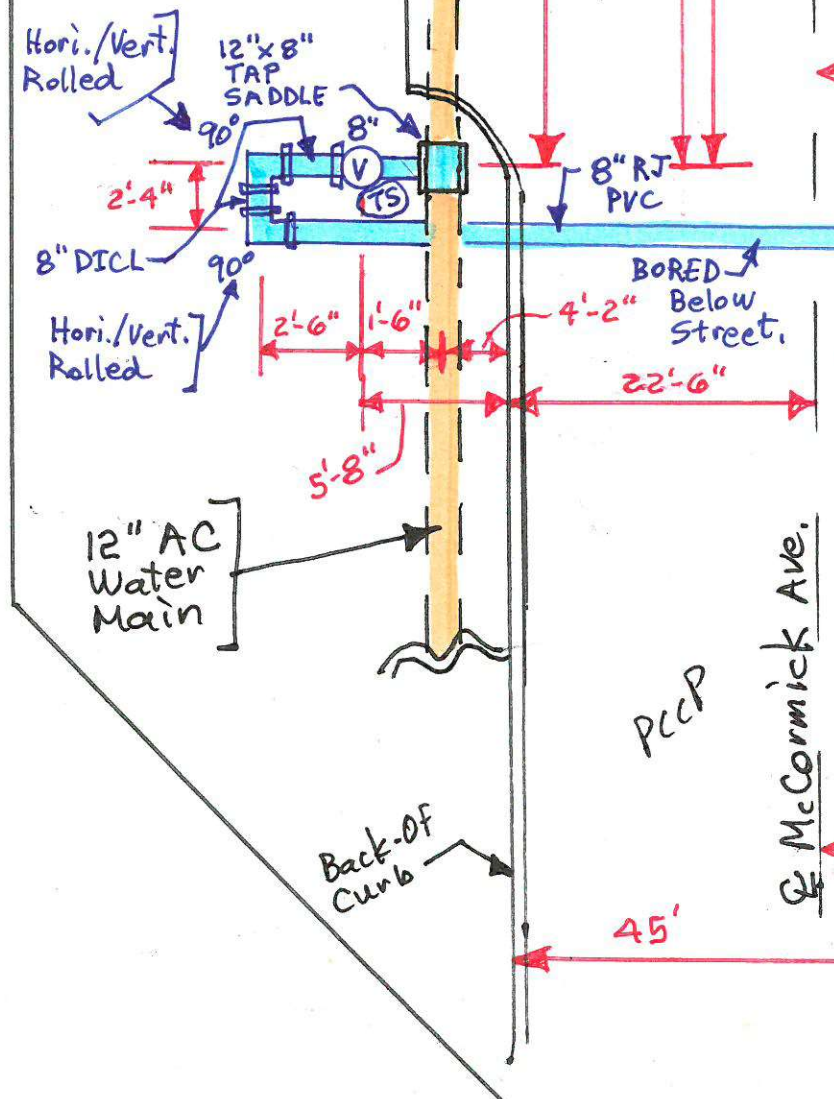

- NOTES:**
- Ⓐ Top of 6" DICL Pipe is 61" Below Top Finish Floor.
  - Ⓑ Gap between Bottom of Bldg's Footing and Top of 6" DICL Pipe = 23"
  - Ⓒ 12" FH Extension installed.