

SHALLOW TYPE "P" MANHOLE

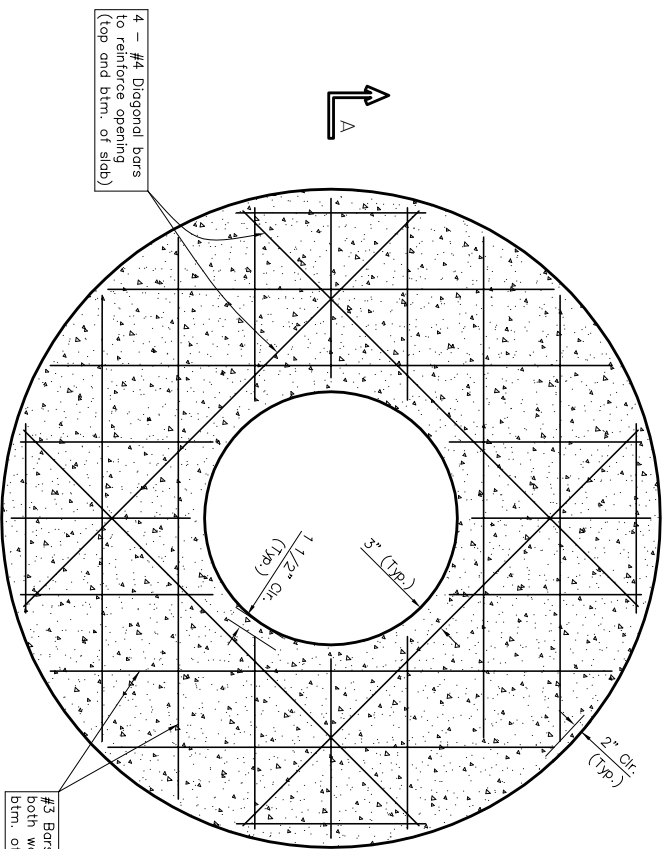

PLAN

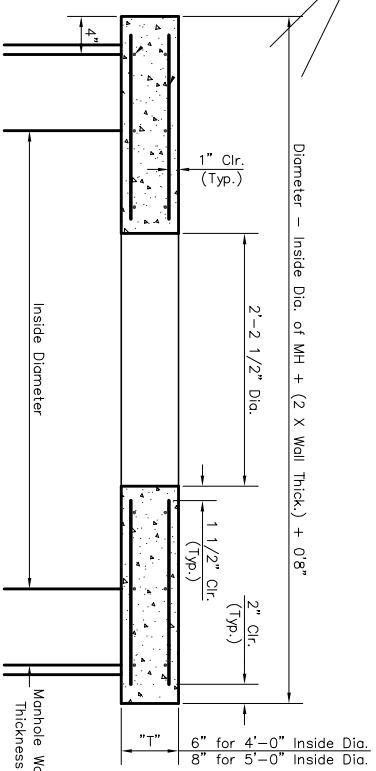

CONCRETE SLAB DETAILS

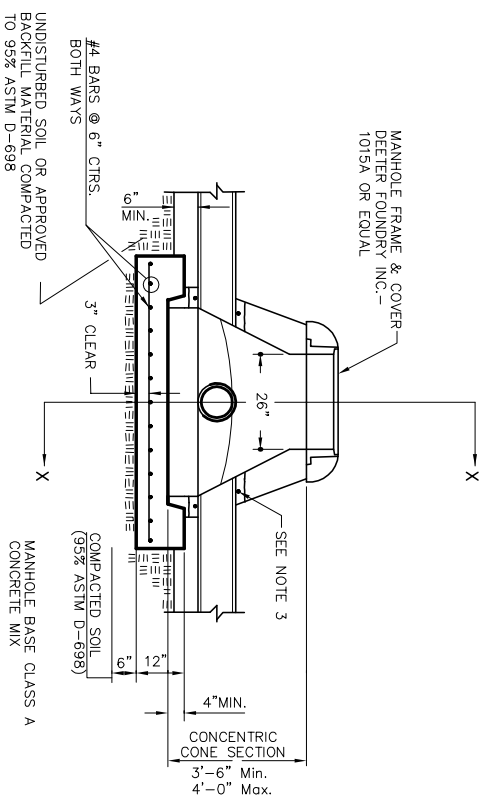

SPECIAL SHALLOW TYPE "P" MANHOLE

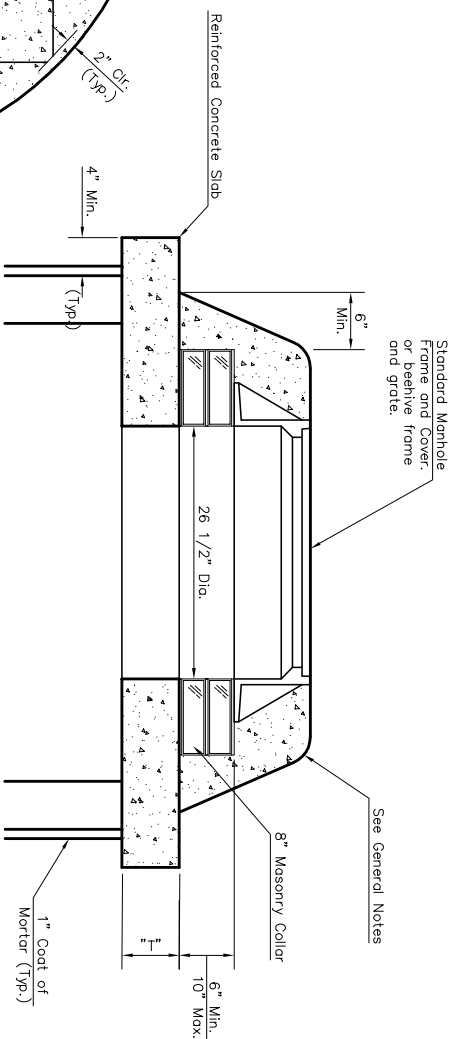

MASONRY COLLAR DETAIL

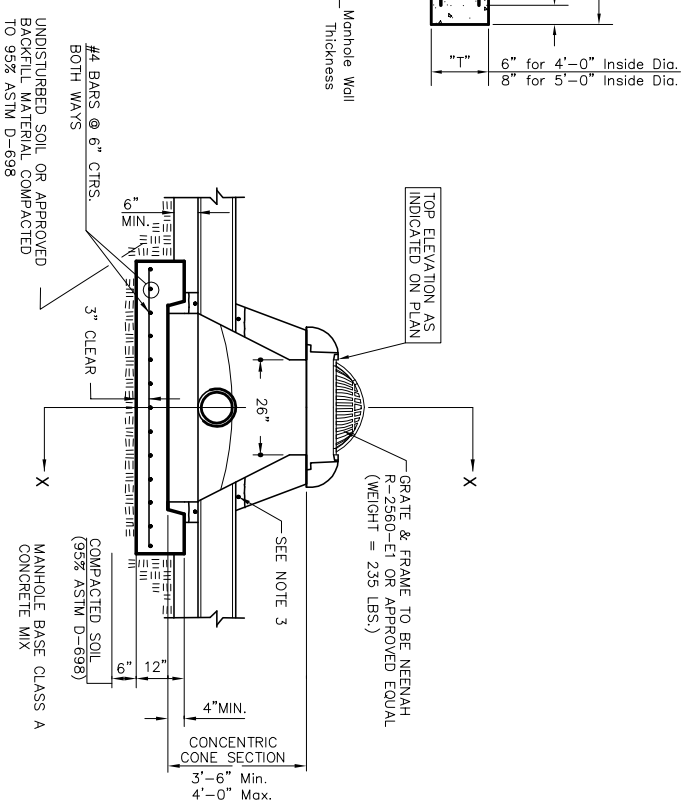

SPECIAL SHALLOW TYPE "P" MANHOLE WITH BEEHIVE FRAME & GRATE

GENERAL NOTES

1. ALL PRECAST CONCRETE MANHOLE SECTIONS SHALL CONFORM TO THE LATEST REVISIONS OF A.S.T.M. C478 AS MODIFIED BY THE SPECIFICATIONS.
2. NON-SHRINK GROUT SHALL BE NON-METALLIC TYPE.
3. APPROVED FLEXIBLE WATERSTOP CASSETS SHALL BE INSTALLED TO SEAL JOINTS BETWEEN MANHOLE SECTIONS. THE JOINTS OF THE SEWER PIPE OR P.V.C. PIPE IS USED FOR OTHER TYPES OF PIPE THE SEWER PIPE SHALL BE SUPPORTED WITH CONCRETE ENCASEMENT A MINIMUM OF 3 FEET FROM THE MANHOLE WALL AND TO THE FIRST JOINT FOR V.C.P. SUCH THAT THE JOINT REMAINS FLEXIBLE.
4. ALL INSIDE SURFACES OF THE CONCRETE MANHOLE WHICH WOULD BE EXPOSED TO SEWER GAS SHALL BE COATED WITH 2 COATS THENCE SERIES 66 HI-BUILD EPOXYLINE, DRY THICKNESS OF 8 MILS (MIN.)
5. EXTERIOR MANHOLE WALLS SHALL BE COATED WITH 1 COAT MOBILARMA 633 BITUMINOUS COATING.
6. JOINT SEALING COMPOUND SHALL BE KENT SEAL NO. 2 OR APPROVED EQUAL.
7. PRECAST MANHOLES SHALL BE SET AT LEAST 4 INCHES INTO THE MANHOLE BASE.
8. TOP OF MANHOLE FLOOR SLAB SHALL BE AT LEAST 3 INCHES BELOW THE FLOW LINE OF THE OUTER PIPE TO INSURE SUFFICIENT MINIMUM THICKNESS OF SHAPED INVERT.
9. LIFTING HOLES SHALL BE FILLED WITH NON-SHRINK GROUT AND THE INTERIOR SURFACE COATED AS SPECIFIED.
10. MORTAR USED IN MASONRY CONSTRUCTION SHALL CONTAIN 8 BAGS OF PORTLAND PER CUBIC YARD CONCRETE USED IN MANHOLE BASES SHALL BE CLASS A CONCRETE THROUGHOUT MORTAR SHALL BE PLACED AROUND THE MANHOLE RING AS SHOWN ON THE DRAWINGS WHEN MANHOLES ARE CONSTRUCTED IN UNPAVED AREAS. MANHOLES CONSTRUCTED WHERE PIPE SIZES ARE SMALLER THAN 24" SHALL HAVE AN INSIDE DIAMETER OF 4" MANHOLES CONSTRUCTED WHERE PIPE SIZES ARE 24" OR LARGER SHALL HAVE AN INSIDE DIAMETER OF 5". COMPLETED MANHOLE SHALL BE WITHOUT LEAKS AND WATER TIGHT.
11. REINFORCING STEEL SHALL BE INSTALLED IN THE MANHOLE BASES AND SHALL CONSIST OF NO. 4 BARS PLACED ON 6" CENTERS IN BOTH DIRECTIONS. THE MANHOLE BASE REINFORCEMENT SHALL BE PLACED AT LEAST 3" ABOVE THE BOTTOM OF THE MANHOLE BASE. ALL COSTS FOR REINFORCEMENT SHALL BE THE RESPONSIBILITY OF THE BIDDER. THE UNIT PRICE BID FOR THE MANHOLE.
12. THE FLOORS OF ALL MANHOLES SHALL BE SHAPED WITH FLOW CHANNELS SUCH THAT THE MANHOLES WILL BE SELF CLEANING AND FREE OF AREAS WHERE SOLIDS COULD BE DEPOSITED AS SEWAGE FLOWS THROUGH THE MANHOLE FROM ALL INLET PIPES TO THE OUTLET PIPE. FLOW CHANNELS SHALL BE SHAPED TO PERMIT PIPES TO BE REMOVED. THE FLOW CHANNELS PIPES AND THE OUTLETING PIPE AS SHOWN BY THE DRAWINGS EXCEPT FOR INSIDE DROP MANHOLES. FLOW CHANNELS FOR INSIDE DROP MANHOLES SHALL BE CONSTRUCTED AS INDICATED BY THE DRAWING. MANHOLE FLOORS SHALL HAVE SLOPES OF 3 INCHES PER FOOT IN THE AREAS OUTSIDE OF THE FLOW CHANNELS SLOPED TOWARD THE FLOW CHANNELS. PIPES LEAD THROUGH MANHOLES SHALL HAVE THE TOP HALF OF THE PIPES SHAPED TO PERMIT PIPES TO BE REMOVED. MANHOLE MANHOLE FLOORS SHALL THEN BE SHAPED AROUND THE BOTTOM HALF OF THE PIPE WHICH FORMS THE FLOW CHANNEL.
13. PIPES INSTALLED WITHIN THE EXCAVATION MADE FOR THE MANHOLE SHALL BE GRADED WITH CONCRETE TO THE LIMITS OF THE MANHOLE EXCAVATION. WHEN CONCRETE IS USED, THE GRADE SHALL EXTEND TO EXTERIOR SURFACE OF THE MANHOLE. THE GRADE SHALL BE PLACED IN A MANNER WHICH WILL MAINTAIN THE FLEXIBILITY OF THE JOINT. COST OF GRADE WITHIN MANHOLE EXCAVATION OR TO CLAY PIPE JOINTS ADJACENT TO MANHOLE SHALL BE INCLUDED IN THE UNIT PRICE BID FOR THE MANHOLE.
14. MANHOLE COVER CASTINGS AND MANHOLE FRAME CASTINGS SHALL CONFORM TO THE REQUIREMENTS AS INDICATED IN THE STANDARD SPECIFICATIONS AND AS SHOWN IN THE STANDARD DETAIL DRAWING.
15. ALL BRICK USED IN MANHOLE CONSTRUCTION SHALL MEET GRADE SW OF ASTM C652 OR C62-87.

SHALLOW TYPE "P" MANHOLE DETAILS WITH BEEHIVE INLET

	Rugles & Bohm, P.A. Engineering, Surveying, Land Farming 924 North Main Wichita, Kansas 67203 www.rtkansas.com	(316) 264-8008 (316) 264-4821 fax E-mail: info@rtkansas.com	PROJECT NUMBER 489-84339	DATE Mar. 20, 2007
	DESIGN C.O.W.	DRAWN C.O.W.	REVIEW C.O.W.	SHEET 20
DRAWING TITLE Details [beehive]	PROJECT NUMBER 489-84339	DATE Mar. 20, 2007	SHEET 22	