

# Typical Bridge Improvements

# Bridge Deck Approach with Sidewalk



Revision Schedule		
No.	Date	Description
1	10/6/2023	PERMIT SET
2	1/23/2024	REVISED SET FOR REBID

**L.W. CLAPP PARK**  
 CITY OF WICHITA  
 4611 E HARRY STREET  
 WICHITA, KS 67218

Project Number	19305
Issue	PERMIT SET
Date	2023-10-06

**2**  
**11**

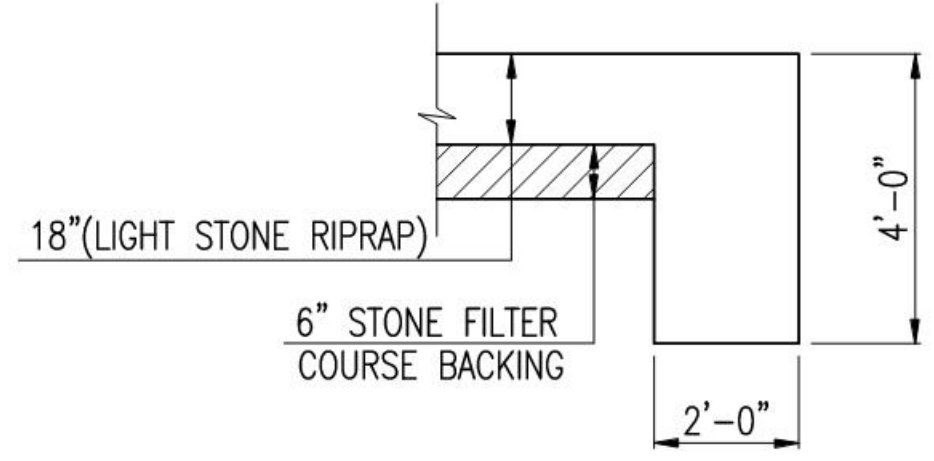
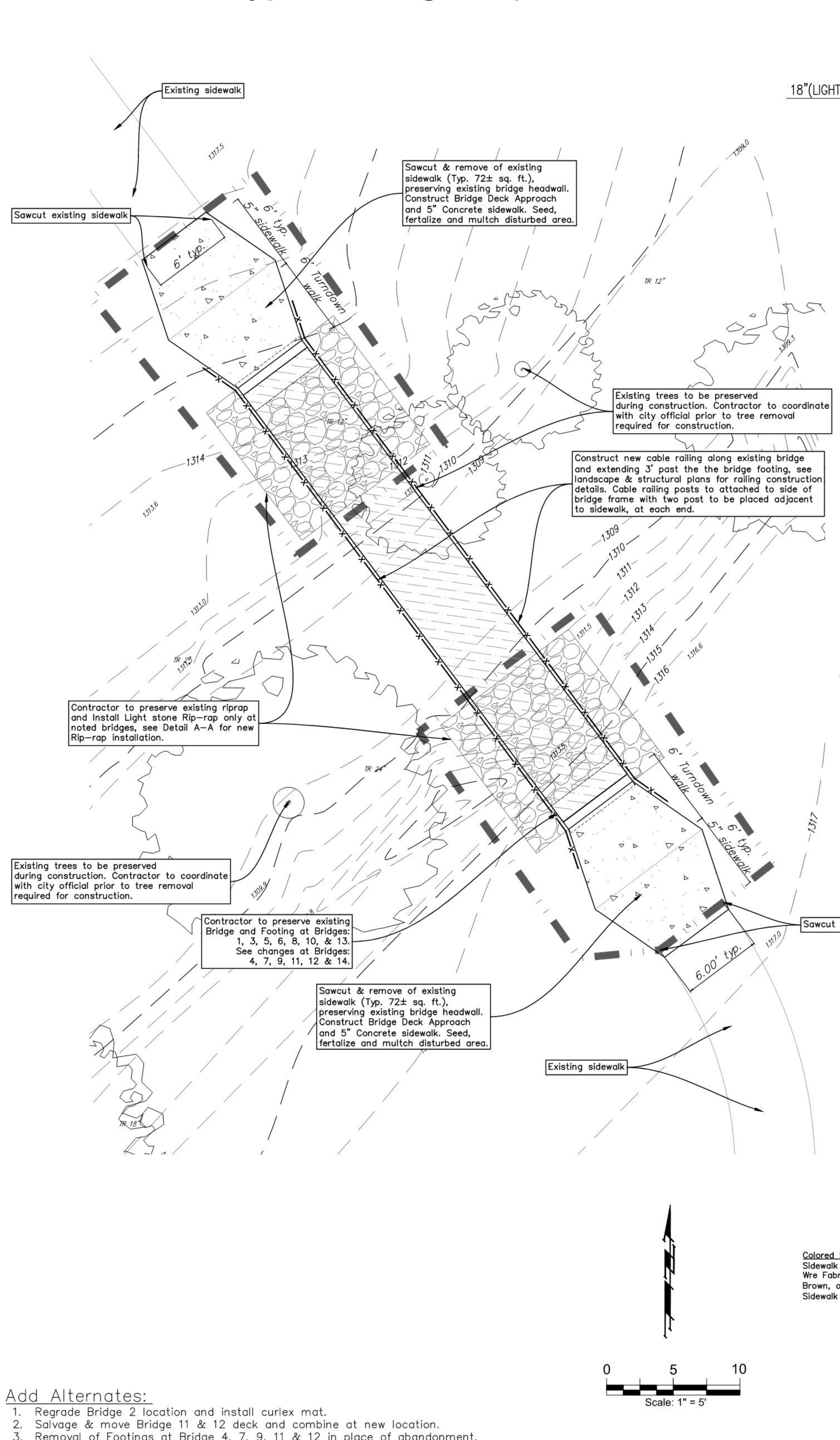

- NOTES
- ALL RIPRAP FOR THIS PROJECT SHALL BE NATURAL STONE. NEITHER BROKEN CONCRETE, FABRIC ENVELOPE, NOR PREMIXED DRY PACKAGED CONCRETE BAG ALTERNATES WILL BE ALLOWED, UNLESS INDICATED OTHERWISE.
  - TOEWALLS SHALL BE INSTALLED ALONG ALL UNPROTECTED EDGES OF STONE RIPRAP.
  - GROUTING OF THE SURFACE OF THE RIPRAP SHALL NOT BE PERFORMED, UNLESS INDICATED OTHERWISE. GROUTING OF THE TOEWALLS SHALL BE PERFORMED PER CITY SPECIFICATIONS.

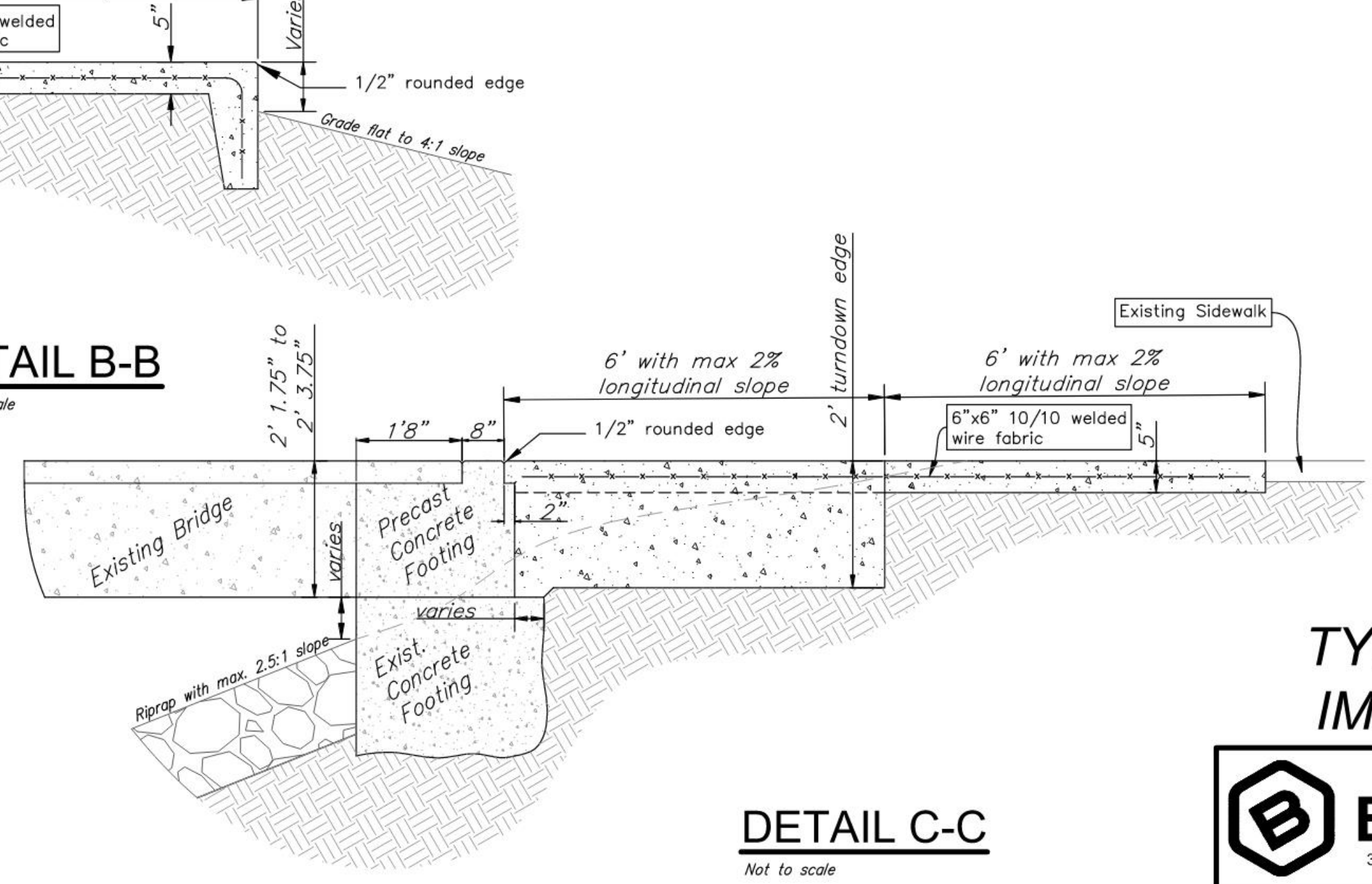
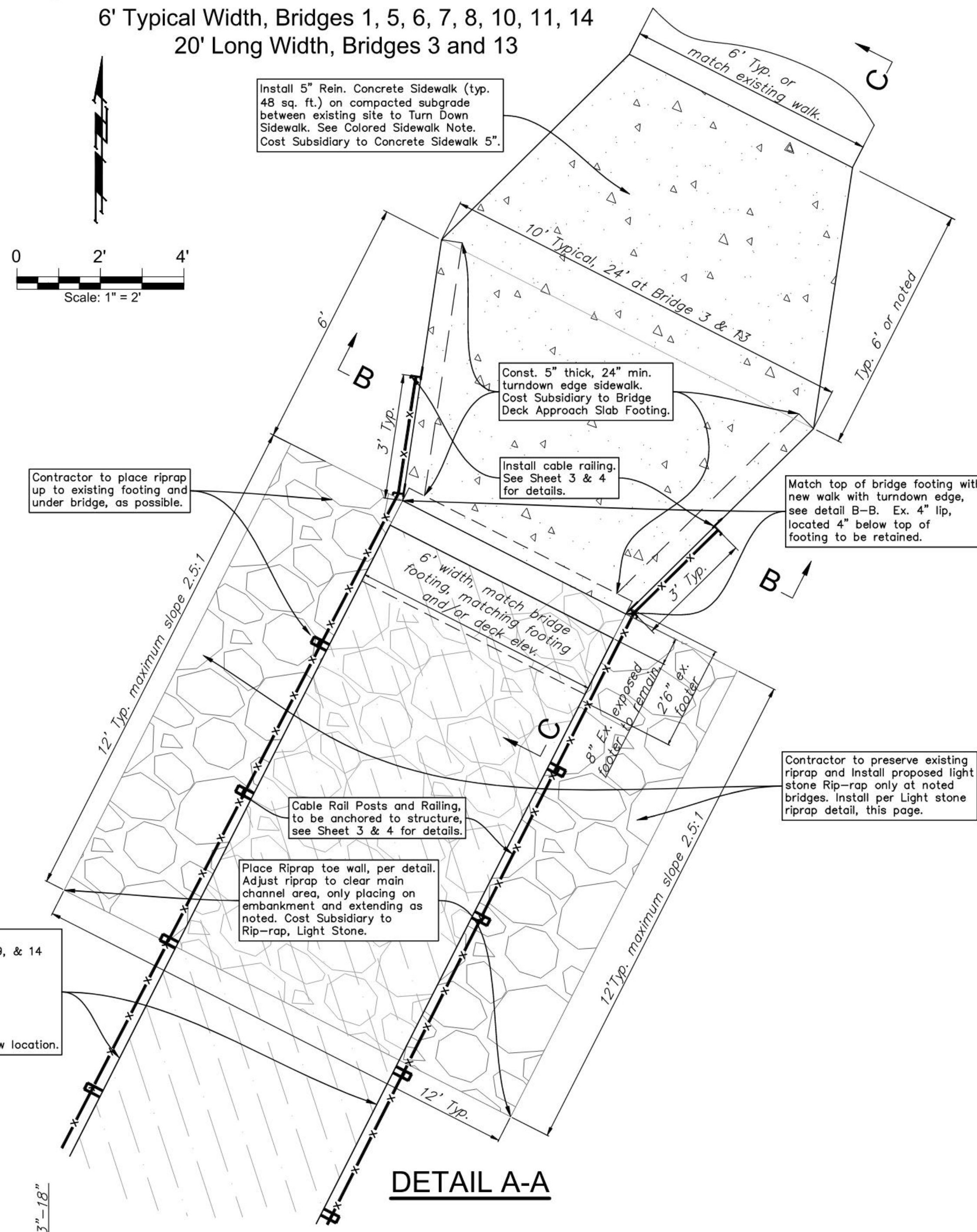
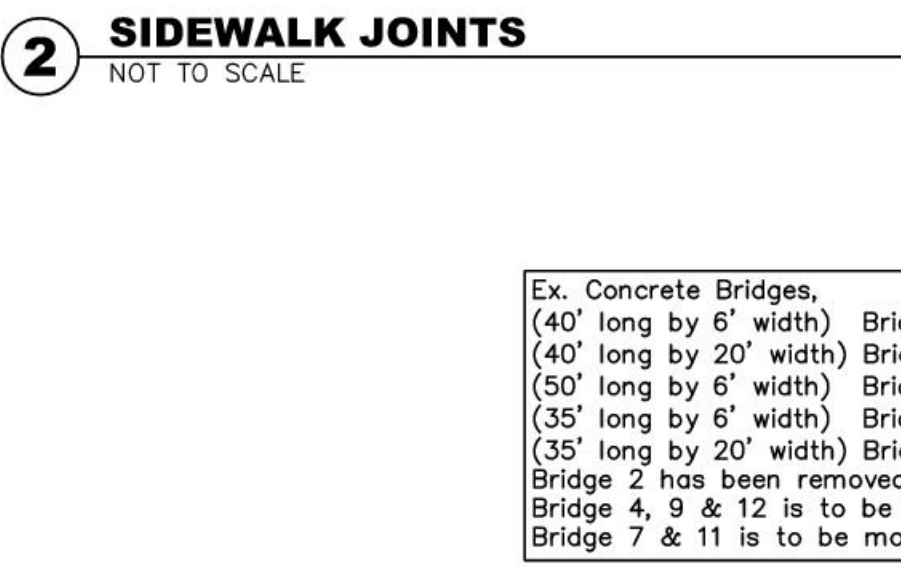
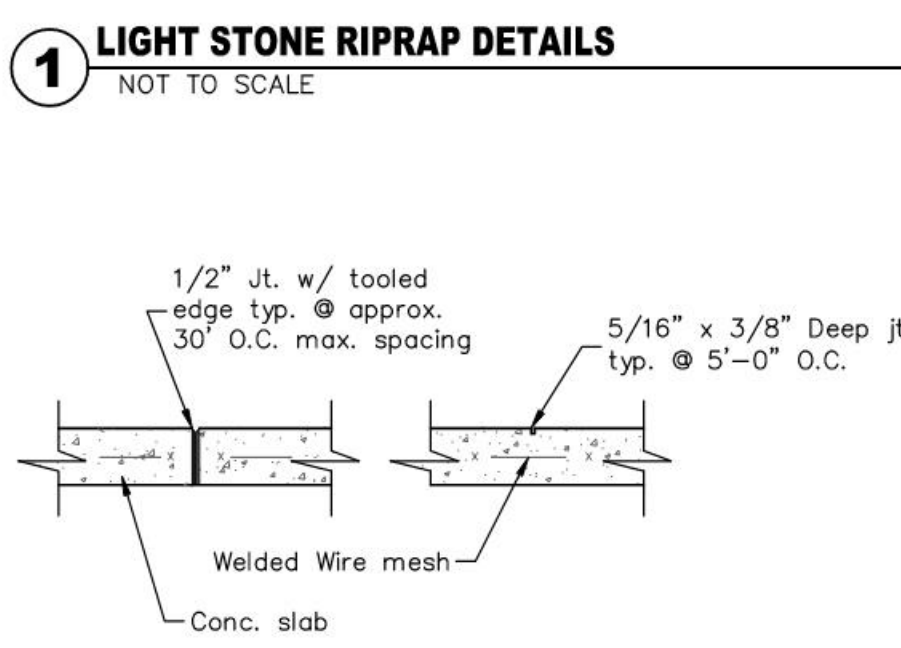

**Colored Sidewalk Note:**  
 Sidewalk areas noted to be 5" thick, shall be reinforced with Welded Wire Fabric. The surface shall be broom finished and colored Mocha Brown, or approved equal. Cost to be subsidiary to "Concrete Sidewalk 5".

- Add Alternates:
- Regrade Bridge 2 location and install curlex mat.
  - Salvage & move Bridge 11 & 12 deck and combine at new location.
  - Removal of Footings at Bridge 4, 7, 9, 11 & 12 in place of abandonment.
  - Substitute 6"x1" IPE Wood for the Base Treated Wood for Railing Top Frame. Substitute Stainless Steel Cables for the base Galv. Steel Cable.

THE LINE SHOWN ABOVE IS EXACTLY ONE FOOT LONG AT THIS SCALE & ORIGNAL PAPER SIZE.  
 THE SQUARE SYMBOLS ARE FOR COLOR WITH BLACK AND WHITE LETTERS. IF PRINTED IN COLOR.

File Location: E:\Projects\Clapp Park PH1 - Gypsum Creek Bridge Replacement (23-01-E414)\Engineering\Clapp Park Base / SAVE DATE: 2/7/2024 3:37 PM BY: pat / PLOT DATE: 2/7/2024 4:11 PM BY: pat